



Dated this 16<sup>th</sup> day of September, 2015.

**OFFICE OF THE ATTORNEY GENERAL**  
Elizabeth Barrett-Anderson, Attorney General

By:



**THOMAS P. KEELER**  
Assistant Attorney General

**Index of the following correspondence**  
**Department of Public Works – Exhibit C**

- a. DPW 10-17-14 Letters to Korando, GTA and Docomo re Pre-Construction Conf.
- b. DPW 12-29-14 Notice to Proceed
- c. DPW 03-19-15 Letter to Korando re Concern with Lack of Progress
- d. DPW 04-24-15 Letter to Korando re Schedule Delays Clarifications to Drawings
- e. DPW 04-23-15 Letter to Korando re Clarifications to Drawings
- f. DPW 05-05-15 Letter to Korando re Schedule Delay
- g. DPW 05-05-15 Letter to Korando – Response to 04-27-15 correspondence
- h. DPW 05-13-15 Letter to Korando re Schedule Delay & Extension of Time
- i. DPW 05-20-15 Letter to Korando re Concrete Pedestal
- j. DPW 05-29-15 Letter to Dept. of Labor re Temporary Alien Workers
- k. DPW 06-08-15 Letter re proposed modification of electrical plan
- l. DPW 06-26-15 Notice of Default to Korando
- m. DPW 07-10-15 Letter/Notice to Takagi & Assoc re tender to surety

**Department of Agriculture Correspondences**

- n. Letter from Mariquita F. Taitague dated July 25, 2014  
Re: Bile and Pigua Replacement (construction phase) Project. GU-NH-NBIS (007).

**Guam Environmental Protection Agency Correspondences**

- o. Letter from Angel B. Marquez dated August 29, 2014  
Re: Demolition of Existing Bile & Pigua Bridges and Construct 2-Lane Bridge
- p. Korando Correspondence
  - a. Korando 04-15-15 Response to Schedule Delay
  - b. Korando 04-27-15 Response to DPW Schedule Delay
  - c. Korando 05-27-15 Correspondence re delays
  - d. Korando 07-01-15 Response to Notice of Default

**Termination Letter dated July 10, 2015 – Exhibit D**



# EXHIBIT C

A

JMH 5/22/15  
G.P.S.P. FILED



The Honorable  
**Eddie Baza Calvo**  
Governor

The Honorable  
**Ray Tenorio**  
Lieutenant Governor

**public works**  
DIPATAMENTON CHE'CHO PUPBLEKO  
**Carl V. Dominguez**  
Director  
**Jessie B. Palican**  
Deputy Director

October 17, 2014

#06 Sign Spw-Highways Copy to  
**ACKNOWLEDGMENT RECEIPT:**  
NAME: **FRANCISCO PALMA JR**  
DEPT./COMPANY: **KORANDO CORP**  
DATE: **10.20.14** TIME: **2:45 PM**  
SIGNATURE:

Ruel Remetira  
Project Manager  
Korando Corporation  
P.O. Box 20538  
G.M.F., Guam 96921

**Ref: Bile / Pigua Bridge Replacement (Construction Phase)**  
**GU-NH-NBIS(007)**  
**PRE-CONSTRUCTION CONFERENCE**

Dear Mr. Remetira,

This is to inform you that a Pre-Construction conference for the above referenced project has been scheduled for Tuesday, October 21, 2014 at 2:00PM. The conference will be held at the Department of Public Works, Division of Highways, 2<sup>nd</sup> Floor Conference Room.

Should you have any questions or need additional information, please contact Mr. Jack Marlowe, Resident Project Representative at 646-3466 with Stanley Consultants, Mr. Crispin Bensen, Project Engineer, at 649-3115 with Department of Public Works or Mr. David Titzel, Construction Manager, at 648-1066 with Parsons Transportation Group.

Sincerely,

**CARL V. DOMINGUEZ**

Cc: Isidro Duarosan, DPW  
Crispin Bensen, DPW  
Richelle Takara, FHWA  
Jack Marlowe, CM  
David Titzel, PTG

IDuarosan /PSIagel/IBlaz

TND0-9081

9081



The Honorable  
**Eddie Baza Calvo**  
Governor

The Honorable  
**Ray Tenorio**  
Lieutenant Governor

October 17, 2014



**Carl V. Dominguez**  
Director

**Jessie B. Palican**  
Deputy Director

**COPY**

Robert W. Haulbrook, Jr.  
Chief Executive Officer  
GTA TeleGuam LLC  
600 Harmon Loop Road  
Tamuning, Guam 96911

**Ref: Bile / Pigua Bridge Replacement (Construction Phase)**  
**GU-NH-NBIS(007)**  
**PRE-CONSTRUCTION CONFERENCE**

*to NS, Sign for Highway Dept*

ACKNOWLEDGMENT RECEIPT:	
NAME:	Mary A. Cruz
DEPT/COMPANY:	Human Resources
DATE:	10/17/14
TIME:	3:27PM
SIGNATURE:	<i>M.A. Cruz</i>

*Tracywell*

Dear Mr. Haulbrook,

This is to inform you that a Pre-Construction conference for the above referenced project has been scheduled for Tuesday, October 21, 2014 at 2:00PM. The conference will be held at the Department of Public Works, Division of Highways, 2<sup>nd</sup> Floor Conference Room.

The Bile / Pigua Bridge Replacement (Construction Phase) project involves the reconstruction and widening of the Bile and Pigua Bridges to address the immediate concerns to the structural integrity of both existing bridges. These bridges will be constructed with an increase span to widen the existing river opening at the bridges and will include all necessary river embankment upgrades along the upstream and downstream approaches within the proposed right-of-way.

In addition, the road approaches to the bridges will be reconstructed and widened to include, asphalt concrete pavement approach ramps, paved shoulders, installation of ample warning and traffic regulatory signage and pavement markers and markings to direct vehicular movement throughout the limits of this project site, and any other roadway appurtenances, where applicable, to provide for a complete, usable safe facility.

Should you have any questions or need additional information, please contact Mr. Jack Marlowe, Resident Project Representative at 646-3466 with Stanley Consultants, Mr. Crispin Bensen, Project Engineer, at 649-3115 with Department of Public Works or Mr. David Titzel, Construction Manager, at 648-1066 with Parsons Transportation Group.

Sincerely,

  
**CARL V. DOMINGUEZ**

TN00-9070

Cc: Isidro Duarosan, DPW  
Crispin Bensen, DPW  
Richelle Takara, FHWA  
Jack Marlowe, CM  
David Titzel, PTG

   
IDuarosan /PSIagel/JBlaz



JMH 10/22/14

Gr SP FILED



The Honorable  
Eddie Baza Calvo  
Governor

The Honorable  
Ray Tenorio  
Lieutenant Governor



public works  
DIPATTAMENTON CH' CHO PUBBLEKO

Carl V. Dominguez  
Director

Jessie B. Palican  
Deputy Director

October 17, 2014

COPY

Jay R. Shedd  
President & Chief Executive Officer  
Docomo Pacific Guam  
219 S. Marine Corps. Drive, Suite 206  
Tamuning, Guam 96911

Ref: **Bile / Pigua Bridge Replacement (Construction Phase)**  
**GU-NH-NBIS(007)**  
**PRE-CONSTRUCTION CONFERENCE**

\*Pls, sign down Highway copy\*

ACKNOWLEDGMENT RECEIPT:	
NAME:	Carolyn Imperial
DEPT./COMPANY:	DOCOMOPACIFIC TAM
DATE:	10/17/14
TIME:	5:13 pm
SIGNATURE:	<i>[Signature]</i>

*[Signature]*

Dear Mr. Shedd,

This is to inform you that a Pre-Construction conference for the above referenced project has been scheduled for Tuesday, October 21, 2014 at 2:00PM. The conference will be held at the Department of Public Works, Division of Highways, 2<sup>nd</sup> Floor Conference Room.

The Bile / Pigua Bridge Replacement (Construction Phase) project involves the reconstruction and widening of the Bile and Pigua Bridges to address the immediate concerns to the structural integrity of both existing bridges. These bridges will be constructed with an increase span to widen the existing river opening at the bridges and will include all necessary river embankment upgrades along the upstream and downstream approaches within the proposed right-of-way.

In addition, the road approaches to the bridges will be reconstructed and widened to include, asphalt concrete pavement approach ramps, paved shoulders, installation of ample warning and traffic regulatory signage and pavement markers and markings to direct vehicular movement throughout the limits of this project site, and any other roadway appurtenances, where applicable, to provide for a complete, usable safe facility.

Should you have any questions or need additional information, please contact Mr. Jack Marlowe, Resident Project Representative at 646-3466 with Stanley Consultants, Mr. Crispin Bensen, Project Engineer, at 649-3115 with Department of Public Works or Mr. David Titzel, Construction Manager, at 648-1066 with Parsons Transportation Group.

Sincerely,

*[Signature]*  
CARL V. DOMINGUEZ

TN00-0071



*Bile / Pigua Bridge Replacement (Construction Phase) GU-NH-NBIS(007)*  
PRE-CONSTRUCTION CONFERENCE Page 2 of 2

Cc: Isidro Duaroson, DPW  
Crispin Bensen, DPW  
Richelle Takara, FHWA  
Jack Marlowe, CM  
David Titzel, PTG

   
IDuarosan /PSlagel/JBlaz



COPY



The Honorable  
Eddie Baza Calvo  
Governor

The Honorable  
Ray Tenorio  
Lieutenant Governor



Carl V. Dominguez  
Director  
Jessie B. Palican  
Deputy Director

December 29, 2014

Mr. Byong Ho Kim  
President  
Korando Corporation  
380H Harmon Industrial Park  
Tamuning, Guam 96913

Re: **Bile / Pigua Bridges Replacement**  
**Project No. GU-NH-NBIS(007)**  
**NOTICE TO PROCEED**

\* Please sign & return to DPW - Highways \*

<b>ACKNOWLEDGMENT RECEIPT:</b>	
NAME:	JONI PALMA
DEPT./COMPANY:	KORANDO COAP
DATE:	1.2.15 TIME: 2:28 PM
SIGNATURE:	<i>[Signature]</i>

Thank you! !!

Dear Mr. Kim,

You are hereby notified to commence work on the above referenced project on **Monday, January 5, 2015** which shall be day number one (1) of the working days stipulated in the Contract. All work, including final cleanup shall be completed within **450** calendar days. Failure to complete the entire project within the **500** calendar days stipulated in the contract will result in Liquidated Damages being assessed in the amount of **\$2,200.00** per calendar day.

All changes, deviations from, or clarifications to the plans and specifications will be valid only if directed, in writing, by the Department of Public Works Contracting Officer. All inspections, acceptance testing and other requirements shall be coordinated with the Department of Public Works.

**Please include the above Project Name and Project Number on all project correspondence.**

Should you have any questions or need additional information, please contact Mr. Jack Marlow, Chief Resident Project Representative with Stanley Consultants at 646-3466, Mr. Crispin Bensen, Project Engineer, DPW or Mr. Mike Lanning, Guam Program Manager with Parsons Transportation Group at 648-1060.

Acknowledge receipt of this notice on the space provided below and return a copy to the Department of Public Works, Division of Highways to the attention of Mr. Isidro Duarosan, Engineer Supervisor.

Sincerely,



CARL V. DOMINGUEZ



IDuatoan/PSlagel /JBlaz

Cc Jack Marlow, Stanley  
Crispin Bensen, DPW  
Mike Lanning, PTG  
Richelle Takara, FHWA

RECEIPT OF THE ABOVE NOTICE TO PROCEED IS HEREBY ACKNOWLEDGED

THIS \_\_\_\_\_ DAY OF \_\_\_\_\_ 2014.

By: \_\_\_\_\_ Signature: \_\_\_\_\_  
(Print Name & Title)



The Honorable  
Eddie Baza Calvo  
Governor

The Honorable  
Ray Tenorio  
Lieutenant Governor

Jan 5/2015  
Gr SP FILED  
**COPY**  
The logo for the Department of Public Works, featuring a stylized bridge and the text 'public works' and 'DIPATTAMENTON CHE'CHO PUPBLEKO'.  
Carl V. Dominguez  
Director  
Jessie B. Palican  
Deputy Director

December 29, 2014

Mr. Byong Ho Kim  
President  
Korando Corporation  
380H Harmon Industrial Park  
Tamuning, Guam 96913

**Re: Bile / Pigua Bridges Replacement**  
**Project No. GU-NH-NBIS(007)**  
**NOTICE TO PROCEED**

Dear Mr. Kim,

You are hereby notified to commence work on the above referenced project on **Monday, January 5, 2015** which shall be day number one (1) of the working days stipulated in the Contract. All work, including final cleanup shall be completed within **450** calendar days. Failure to complete the entire project within the **500** calendar days stipulated in the contract will result in Liquidated Damages being assessed in the amount of **\$2,200.00** per calendar day.

All changes, deviations from, or clarifications to the plans and specifications will be valid only if directed, in writing, by the Department of Public Works Contracting Officer. All inspections, acceptance testing and other requirements shall be coordinated with the Department of Public Works.

**Please include the above Project Name and Project Number on all project correspondence.**

Should you have any questions or need additional information, please contact Mr. Jack Marlow, Chief Resident Project Representative with Stanley Consultants at 646-3466, Mr. Crispin Bensen, Project Engineer, DPW or Mr. Mike Lanning, Guam Program Manager with Parsons Transportation Group at 648-1060.

Acknowledge receipt of this notice on the space provided below and return a copy to the Department of Public Works, Division of Highways to the attention of Mr. Isidro Duarosan, Engineer Supervisor.

NTP

Sincerely,



CARL V DOMINGUEZ



IDuarosan/PSHagel /JBiaz

Cc Jack Marlow, Stanley  
Crispin Bensen, DPW  
Mike Lanning, PTG  
Richelle Takara, FHWA

RECEIPT OF THE ABOVE NOTICE TO PROCEED IS HEREBY ACKNOWLEDGED

THIS 2nd DAY OF JANUARY 2014. 5

By: BYONG HO KIM - PRESIDENT  
(Print Name & Title)

Signature: 

*W*



2

Int 5/22/16  
G<sup>o</sup> SP FILED

COPY

The Honorable  
Eddie Baza Calvo  
Governor

The Honorable  
Ray Tenorio  
Lieutenant Governor



Glenn Leon Guerrero  
Director  
Felix C. Benavente  
Deputy Director

MAR 19 2015

Mr. Byong Ho Kim  
President  
Korando Corporation  
380H Harmon Industrial Park  
Tamuning, Guam 96913

Re: **Bile / Pigua Bridges Replacement**  
**Project No. GU-NH-NBIS(007)**  
**Schedule Delay**

ACKNOWLEDGMENT RECEIPT:	
NAME:	Patsy Jaleo
DEPT./COMPANY:	Korando Corp
DATE:	3/20/15
TIME:	4:45
SIGNATURE:	[Signature]

Dear Mr. Kim,

The Department of Public Works is concerned over the lack of progress on the above referenced project. More than 11 weeks have passed since the Notice to Proceed was issued on January 5, 2015 without any work performed on site other than a survey.

Korando Corporation submitted the February 2015 update to the approved baseline schedule indicating a construction completion date of May 9, 2016. This is 41 days beyond the Contract Completion Date of March 29, 2016. Activity A1170 for the design, fabrication and delivery of the prestressed precast concrete piles is the controlling activity at present. The test piles have not been cast or driven and the production lengths have not been determined. Based on the lack of progress on this activity alone, we estimate that Korando may be nearly two months behind the approved baseline schedule at the present time.

Korando has also submitted a revised baseline schedule showing a completion date of March 29, 2016. However, a preliminary review reveals several issues that make this schedule appear overly optimistic. These include:

- Revised Temporary Utility Plans - The contractor has proposed an alternate phasing plan with new bridge construction starting on the ocean side rather than the mountain side. This requires the temporary utility plans to be revised, including power, water and communications. Korando has not yet submitted the revised plan for review.
- Temporary Traffic Control Plans - The alternate phasing plan proposed by Korando also revises the traffic control plan shown in the contract. Korando has been instructed to submit a detailed traffic control plan for the revised phasing. An approved plan is required before the temporary maintenance of traffic can be established.
- Utility Relocation Plans - The schedule indicates that there are more than 200 days of float for preparing the utility relocation plans and procuring material (Activities A1160, A1190, A1200 and A1210). This cannot be correct. Korando's schedule indicates starting the installation of power poles on March 23, 2015 and Korando has not submitted the

TN15-0299

utility relocation plans or submitted for approval any of the electrical materials including the power poles.

- Precast Prestressed Concrete Piles – Korando’s schedule is based on eliminating test piles and estimating production pile lengths based solely on boring data. This will not be approved. The additional time for the test piles prior to casting the production piles has not been included in the schedule.

Response to Korando’s revised baseline schedule will be provided separately.

In accordance with FAR Section 52.236-15 as referenced in FP-03 Section 155.01, Korando is instructed to take steps necessary to improve its progress without additional cost to the Government. This may include increasing the number of shifts, overtime operations, days of work, labor, equipment, and/or the resequencing of the work.

In accordance with FP-03 Section 108.04, liquidated damages in the amount \$2,200 will be assessed for each day beyond the Contract Completion Date until substantial completion of the work. Liquidated damages in the amount of \$440 will be assessed for each day beyond the Contract Completion Date beginning with the day after substantial completion and ending with the date of final completion and acceptance.

Should you have any questions or need additional information, please contact Mr. Jack Marlow, Chief Resident Project Representative with Stanley Consultants at 646-3466, Mr. Crispin Bensen, Project Engineer, DPW or Mr. Houston Anderson, Construction Manger with Parsons Transportation Group at 648-1066.

Acknowledge receipt of this notice on the space provided below and return a copy to the Department of Public Works, Division of Highways to the attention of Mr. Isidro Duarosan, Engineer Supervisor.

Sincerely,



*f*  
**GLENN LEON GUERRERO**

Cc: Jack Marlow, Stanley  
Crispin Bensen, DPW  
Houston Anderson, PTG  
Richelle Takara, FHWA



Duarosan/PSlagel/JBlaz





*The Honorable*  
**Eddie Baza Calvo**  
*Governor*

*The Honorable*  
**Ray Tenorio**  
*Lieutenant Governor*



**Glenn Leon Guerrero**  
*Director*  
**Felix C. Benavente**  
*Deputy Director*

Mr. Byong Ho Kim  
President  
Korando Corporation  
380H Harmon Industrial Park  
Tamuning, Guam 96913

**Re: Bile / Pigua Bridges Replacement**  
**Project No. GU-NH-NBIS(007)**  
**Schedule Delay**

Dear Mr. Kim,

The Department of Public Works is concerned over the lack of progress on the above referenced project. More than 11 weeks have passed since the Notice to Proceed was issued on January 5, 2015 without any work performed on site other than a survey.

Korando Corporation submitted the February 2015 update to the approved baseline schedule indicating a construction completion date of May 9, 2016. This is 41 days beyond the Contract Completion Date of March 29, 2016. Activity A1170 for the design, fabrication and delivery of the prestressed precast concrete piles is the controlling activity at present. The test piles have not been cast or driven and the production lengths have not been determined. Based on the lack of progress on this activity alone, we estimate that Korando may be nearly two months behind the approved baseline schedule at the present time.

Korando has also submitted a revised baseline schedule showing a completion date of March 29, 2016. However, a preliminary review reveals several issues that make this schedule appear overly optimistic. These include:

- Revised Temporary Utility Plans – The contractor has proposed an alternate phasing plan with new bridge construction starting on the ocean side rather than the mountain side. This requires the temporary utility plans to be revised, including power, water and communications. Korando has not yet submitted the revised plan for review.
- Temporary Traffic Control Plans – The alternate phasing plan proposed by Korando also revises the traffic control plan shown in the contract. Korando has been instructed to submit a detailed traffic control plan for the revised phasing. An approved plan is required before the temporary maintenance of traffic can be established.
- Utility Relocation Plans – The schedule indicates that there are more than 200 days of float for preparing the utility relocation plans and procuring material (Activities A1160, A1190, A1200 and A1210). This cannot be correct. Korando's schedule indicates starting the installation of power poles on March 23, 2015 and Korando has not submitted the

542 North Marine Corps Drive, Tamuning, Guahan 96913, Tel (671) 646-3131, Fax (671) 649-6178

TN15-0299

0

The Honorable  
Eddie Baza Calvo  
Governor

The Honorable  
Ray Tenorio  
Lieutenant Governor

COPY

JMH 5/22/15  
Gr SP FILED



public works  
DEPARTAMENTO DE OBRAS PUBLICAS  
Glenn Leon Guerrero  
Director  
Felix C. Benavente  
Deputy Director

APR 24 2015

Mr. Ruel Remetira  
Project Manager  
Korando Corporation  
P.O. Box 20538  
GMF, GU 96921

Korando Corp.  
PATTY JAKECO

Rec'd  
Patty Jakeco  
4/24/15

Ref: **Bile/Pigua Bridge Replacement**  
**Project No. GU-NH-NBIS(007)**  
**PRECAST/PRESTRESSED CONCRETE PILE - CLARIFICATIONS**  
**DRAWINGS S1, S19 AND S20**

Dear Mr. Remetira:

Please note the following clarifications to the information given on Drawings S1, S19 and S20 with regard to the precast/prestressed concrete piles.

1. Provide test piles having the following minimum lengths:
  - a. Bile Bridge: 4 test piles X 40 foot each
  - b. Pigua Bridge: 4 test piles X 110 foot each
2. Pile Cut-off Elevations:
  - a. Cut off piles at the elevation of the bottom of the top longitudinal pile cap reinforcement.
  - b. Carefully remove pile concrete from the cut-off elevation to a height of 10 inches above the bottom of the pile cap per Drawings S19 & S20. Take care to not damage the reinforcing strands or spiral reinforcement.
  - c. Splay the reinforcing strands as shown on Drawings S19 and S20.
  - d. Cut and remove the spiral reinforcement beyond 1'-6" from the top of the pile concrete as shown on Drawings S19 and S20.
3. Pile Lengths - Pile lengths provided in the Bid Schedule are shown for estimating purposes only. Final pile lengths for payment purposes will be determined as follows:
  - a. Production Piles: Final pile lengths for payment purposes will be based on the production lengths determined by results of dynamic testing (indicator piles). (Re: Drawing S1 General Structural Note 5.)
  - b. Test Piles: Final pile lengths for payment purposes will be the production lengths as directed.





*The Honorable*  
**Eddie Baza Calvo**  
*Governor*

*The Honorable*  
**Ray Tenorio**  
*Lieutenant Governor*

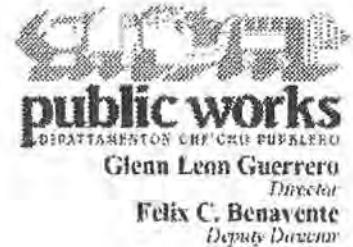

**Glenn Leon Guerrero**  
*Director*  
**Felix C. Benavente**  
*Deputy Director*

APR 24 2015

Mr. Ruel Remetira  
Project Manager  
Korando Corporation  
P.O. Box 20538  
GMF, GU 96921

**Ref: Bile/Pigua Bridge Replacement**  
**Project No. GU-NH-NBIS(007)**  
**PRECAST/PRESTRESSED CONCRETE PILE - CLARIFICATIONS**  
**DRAWINGS S1, S19 AND S20**

Dear Mr. Remetira:

Please note the following clarifications to the information given on Drawings S1, S19 and S20 with regard to the precast/prestressed concrete piles.

1. Provide test piles having the following minimum lengths:
  - a. Bile Bridge: 4 test piles X 40 foot each
  - b. Pigua Bridge: 4 test piles X 110 foot each
2. Pile Cut-off Elevations:
  - a. Cut off piles at the elevation of the bottom of the top longitudinal pile cap reinforcement.
  - b. Carefully remove pile concrete from the cut-off elevation to a height of 10 inches above the bottom of the pile cap per Drawings S19 & S20. Take care to not damage the reinforcing strands or spiral reinforcement.
  - c. Splay the reinforcing strands as shown on Drawings S19 and S20.
  - d. Cut and remove the spiral reinforcement beyond 1'-6" from the top of the pile concrete as shown on Drawings S19 and S20.
3. Pile Lengths - Pile lengths provided in the Bid Schedule are shown for estimating purposes only. Final pile lengths for payment purposes will be determined as follows:
  - a. Production Piles: Final pile lengths for payment purposes will be based on the production lengths determined by results of dynamic testing (indicator piles). (Re: Drawing S1 General Structural Note 5.)
  - b. Test Piles: Final pile lengths for payment purposes will be the production lengths as directed.

- c. The contractor should increase the length of the piles as required to provide fresh heading as well as any additional amounts required by the contractor's method of operation. The cost of any additional length will not be measured for payment.

This clarifies the information provided on the plans. This clarification does not modify, alter or add to the work. Measurement and payment will be made for the piles under Payment Items 55101-0610 and 55101-0620 in accordance with Section 551 of FP-03 and Drawing S1 General Structural Note 5.

If you have any questions or need additional information please contact, Mr. Isidro Duarosan, Supervisor, Federal-Aid Highway Construction Section at 649-3104, Mr. Crispin Bensen, Project Engineer, DPW at 649-3115, Mr. Houston Anderson, Construction Manager, Parsons Transportation Group, Inc. at 648-1066 or Mr. Jack Marlowe, Chief Resident Project Representative, Stanley Consultants at 646-3466.

Sincerely,



**FELIX BENAVENTE**

Attachments: N/A

Cc: Isidro Duarosan, DPW  
Crispin Bensen, DPW  
Richelle Takara, FHWA  
Jack Marlowe, CM  
Joseph Pecht, PTG  
Derrick Lehman, PTG  
Houston Anderson, PTG



IDuarosan / JBlaz

E

The Honorable  
Eddie Baza Cabo  
Governor

The Honorable  
Ray Tenorio  
Lieutenant Governor

COPY

John 5/22/15  
Grisp FILED  
public works  
DEPARTMENT OF PUBLIC WORKS

Glenn Leon Guerrero  
Director

Felix C. Benavente  
Deputy Director

APR 23 2015

Mr. Byong Ho Kim  
President  
Korando Corporation  
P.O. Box 20538  
GMF, GU 96921

ACKNOWLEDGMENT RECEIPT:	
NAME:	PATTY JARECO
DEPT./COMPANY:	KORANDO CORP.
DATE:	4/24/15
TIME:	9:30
SIGNATURE:	<i>[Signature]</i>

Ref: **Bile/Pigua Bridge Replacement**  
**Project No. GU-NH-NBIS(007)**  
**KORANDO LETTER DATED APRIL 15 RE: SCHEDULE DELAY - RESPONSE**  
**TO DPW LETTER, DATED MARCH 19, 2015**

Dear Mr. Kim:

We have reviewed the above-referenced letter sent in response to the Department of Public Works' (DPW's) letter regarding schedule delays. We find that Korando's letter does not provide a satisfactory response to issues raised in our March 19, 2015 letter; nor does the Korando letter outline the steps that will be taken to improve progress as required.

Korando is approximately two months behind the approved baseline schedule. It appears from Korando's letter that much of the fault for this delay is placed on the time required to obtain archaeological clearance for the lay down area and equipment staging area. We also take note of Item 7 in your letter in which you state your intention to request a time extension related to the archaeological works.

Securing of the staging area, including permitting is entirely within Korando's control. Much of the work to secure the staging area could have taken place prior to the Notice to Proceed (NTP). In fact, DPW delayed the issuance of the NTP, which allowed Korando additional time to prepare submittals, perform preliminary survey and preliminary work necessary to secure the staging area. However, Korando had not yet retained an archaeological consultant by the NTP date and did not submit the draft archaeological research plan until one month after NTP. One month later on March 10, 2015 Korando had not yet agreed with their archaeological subconsultant regarding the cost of the foot survey and exploratory excavations. This further delayed the archaeological permitting process.

The delays experienced in securing the staging area were not created by unforeseen activities encountered by Korando as claimed in the above-mentioned letter. Available workspace is detailed in the bid plans. As stated in Special Contract Requirement 107.10 (c) (5)

Archaeological Monitoring, "The contractor shall be responsible for obtaining the appropriate permits and clearances for the use of staging areas outside the Area of Potential Effect (APE) (limits of construction) established for the project." We fail to see any cause for delay due to unforeseen circumstances or circumstances outside the control of the contractor. Consequently, we do not anticipate any extension of the contract time period.

The DPW letter to Korando dated March 19, 2015 instructed Korando to "take steps necessary to improve its progress without additional cost to the Government. This may include increasing the number of shifts, overtime operations, days of work, labor, equipment, and/or resequencing of the work." Korando's letter dated April 15, 2015 does not propose any of the steps mentioned in the DPW letter. We are concerned that Korando does not realize the gravity of the schedule delay. The Contract requires Korando to promptly and faithfully perform said Contract. Failure to complete the work within the contract time period will result in the assessment of liquidated damages in accordance with FP-03 Section 108.04.

Again, in accordance with FAR Section 52.236-15, the DPW letter dated March 19, 2015 instructed Korando to take steps necessary to improve its progress without additional cost to the Government. This may also require the hiring of a qualified construction manager and/or scheduler to assist with developing a recovery plan.

Korando must submit their plan for improving its progress by no later than 14 business days from receipt of this letter. In accordance with FAR Section 52.236-15, failure of the Contractor to comply with the requirements of the Contracting Officer shall be grounds for a determination by the Contracting Officer that the Contractor is not prosecuting the work with sufficient diligence to ensure completion within the time specified in the contract. Upon making this determination, the Contracting Officer may terminate the Contractor's right to proceed with the work.

A copy of this letter is also being provided to Westchester Fire Insurance Company and their Guam agent Takagi & Associates, who provided Korando Corporations Performance and Payment bond for this project.

If you have any questions or need additional information please contact, Mr. Isidro Duarosan, Supervisor, Federal-Aid Highway Construction Section at 649-3104, Mr. Crispin Bengan, Project Engineer, DPW at 649-3115, Mr. Houston Anderson, Construction Manager, Parsons Transportation Group, Inc. at 648-1066 or Mr. Jack Marlowe, Chief Resident Project Representative, Stanley Consultants at 646-3466.



Sincerely,



**GLENN LEON GUERRERO**

Attachments: N/A

Cc: Isidro Duarosan, DPW  
Crispin Bensen, DPW  
Richelle Takara, FHWA  
Jack Marlowe, CM  
Joseph Pecht, PTG  
Derrick Lehman, PTG  
Houston Anderson, PTG  
Westchester Fire Insurance Company c/o Takagi & Associates Inc

  
IDuarosan /JBlaz



F

The Honorable  
Eddie Baza Calvo  
Governor

The Honorable  
Ray Tenorio  
Lieutenant Governor

COPY

JMH 5/22/15  
Gire SP FILED  
public works

DEPARTAMENTO DE OBRAS PÚBLICAS  
Glenn Leon Guerrero  
Director  
Felix C. Benavente  
Deputy Director

MAY 05 2015

Mr. Byong Ho Kim  
President  
Korando Corporation  
P.O. Box 20538  
GMF, GU 96921

Korando Corporation  
Patty Jalco  
Ric's Patty Jalco  
5/5/15

**Ref: Bile/Pigua Bridge Replacement  
Project No. GU-NH-NBIS(007)  
SCHEDULE DELAY AND CONSTRUCTION PHASING PLAN**

Dear Mr. Kim:

At the meeting held at the Department of Public Works (DPW) on April 15, 2015, Korando stated that the construction phasing plan shown on Contract Drawings C-20 to C-23 is not buildable thereby requiring Korando to prepare an alternate construction phasing plan which has delayed the project. Korando said the contract phasing plan is not buildable because the roadway centerline passes over the existing temporary bridge. Korando stated that because the existing temporary bridge extends past the centerline, it will conflict with the Phase 1 construction.

Our review of the plans and data provided by Korando has confirmed that the phasing plan shown in the contract drawings is buildable. It is therefore apparent that Korando has elected to use an alternate plan for their own convenience to correspond to their chosen means and methods for the project. This is demonstrated by the following.

#### **Clearance between Phase 1 Construction and Edge of Existing Bridge**

Drawing S23 shows the edge of the Phase 1 deck 4' from the centerline toward the ocean side. Korando provided the attached drawing of Pigua and Bile Bridge Existing Condition on April 23, 2015. This drawing shows the location of the existing temporary bridges with respect to the centerline. The edge of the Phase 1 deck will be 5" clear of the existing Pigua Bridge (4' - 3'7") and 1'-3" clear of the existing Bile Bridge (4' - 2'9"). This clearance should be enough to set the precast deck planks and then thread nuts on the ends of the post tensioning rods (Re: Drawing S24, Detail 1).

Detail 1 on Drawing S5 clearly shows the roadway centerline passing over the existing temporary Bile and Pigua bridges as shown on the Korando drawing. However, as noted above, this does not cause a conflict between the existing temporary bridges and the proposed



6



The Honorable  
Eddie Baza Calvo  
Governor

The Honorable  
Ray Tenorio  
Lieutenant Governor

COPY

JMH 5/22/15  
GR SP FILED

**GUAM**  
**public works**  
DEPARTMENT OF PUBLIC WORKS  
Glenn Leon Guerrero  
Director  
Felix C. Benavente  
Deputy Director

Takagi & Associates, Inc.

**received**  
05/06/2015 OKAC

MAY 08 2015

Mr. Byong Ho Kim  
President  
Korando Corporation  
P.O. Box 20538  
GMF, GU 96921

Ref: **Bile/Pigua Bridge Replacement**  
**Project No. GU-NH-NBIS(007)**  
**SCHEDULE DELAY – RESPONSE TO KORANDO LETTER, DATED APRIL 27, 2015**

Dear Mr. Kim:

On April 23, 2015 the Department of Public Works (DPW) sent a letter to Korando pointing out that Korando is nearly two months behind schedule and instructed Korando to provide a plan for recovery. Korando's April 27, 2015 response letter offers nothing concerning a viable recovery plan but rather appears to present a claim for a time extension.

This letter will not address all items stated in Korando's letter; however two substantive items will be addressed.

The first item, Korando states that the project was delayed due to building permit not being approved until March 5, 2015. Korando submittal 108.001-01 is the building permit issued by the Department of Public Works building department dated October 30, 2014. A copy of this submittal is attached to this letter.

The second item, Korando provided a recovery schedule with their letter. This recovery (catch up schedule) schedule is not responsive to DPW's concerns as to how Korando will be scheduling the work to complete the project within the remaining amount of contract time. The schedule narrative does not provide DPW with the methods that Korando will use to cure the delay, but instead defends delays that were stated in Korando's letter. There are no discussions of resources, work hours, work week, schedule changes, critical materials, construction methods, etc, that Korando would utilize to make up the time lost on the project. In addition, the submitted schedule is now no longer valid since Korando's has now made a decision to revise their construction phasing plan. The recovery schedule submitted will be returned to Korando as

7715 0600

TN15-0403



*The Honorable*  
**Eddie Baza Calvo**  
*Governor*

*The Honorable*  
**Ray Tenorio**  
*Lieutenant Governor*

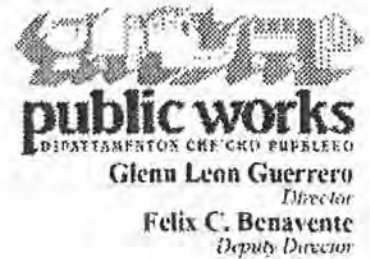

**MAY 05 2015**

Mr. Byong Ho Kim  
President  
Korando Corporation  
P.O. Box 20538  
GMF, GU 96921

**Ref: Bile/Pigua Bridge Replacement**  
**Project No. GU-NH-NBIS(007)**  
**SCHEDULE DELAY AND CONSTRUCTION PHASING PLAN**

Dear Mr. Kim:

At the meeting held at the Department of Public Works (DPW) on April 15, 2015, Korando stated that the construction phasing plan shown on Contract Drawings C-20 to C-23 is not buildable thereby requiring Korando to prepare an alternate construction phasing plan which has delayed the project. Korando said the contract phasing plan is not buildable because the roadway centerline passes over the existing temporary bridge. Korando stated that because the existing temporary bridge extends past the centerline, it will conflict with the Phase 1 construction.

Our review of the plans and data provided by Korando has confirmed that the phasing plan shown in the contract drawings is buildable. It is therefore apparent that Korando has elected to use an alternate plan for their own convenience to correspond to their chosen means and methods for the project. This is demonstrated by the following.

#### **Clearance between Phase 1 Construction and Edge of Existing Bridge**

Drawing S23 shows the edge of the Phase 1 deck 4' from the centerline toward the ocean side. Korando provided the attached drawing of Pigua and Bile Bridge Existing Condition on April 23, 2015. This drawing shows the location of the existing temporary bridges with respect to the centerline. The edge of the Phase 1 deck will be 5" clear of the existing Pigua Bridge (4' - 3'7") and 1'-3" clear of the existing Bile Bridge (4' - 2'9"). This clearance should be enough to set the precast deck planks and then thread nuts on the ends of the post tensioning rods (Re: Drawing S24, Detail 1).

Detail 1 on Drawing S5 clearly shows the roadway centerline passing over the existing temporary Bile and Pigua bridges as shown on the Korando drawing. However, as noted above, this does not cause a conflict between the existing temporary bridges and the proposed

construction. The demolition limits shown in Detail 1/S5 indicate that additional clearance can be obtained, if needed, by the partial demolition of the cantilevered portion of the existing beam below the concrete barrier.

### **Korando's Alternate Phasing Plan is for Contractor Convenience**

Korando's letter to the DPW dated April 15, 2015 includes the following statement: "The alternate phasing plan has been derived to consider the one time pile driving equipment mobilization. The construction of temporary steel bridge is also incorporated in the proposed phasing plan and it has a design to carry load for it is also be use as crane access."

Therefore, Korando, by their own admission, has proposed an alternate construction phasing plan to minimize equipment mobilization and allow crane movement back and forth across the bridge rather that staging a crane on both sides of the bridge. This is for contractor convenience and not due to problems with the design.

Note 2 on Drawing S5 states "The Contractor shall have the option to propose an alternate demolition and construction phasing sequence subject to the review and approval of the Contracting Officer. Alternate scheme will be at no additional cost to the government."

Korando has spent considerable time and resources preparing an alternate construction phasing plan and has yet to submit all the information required. Several submittals have been found to be deficient and have been returned for revision and resubmittal.

We wish to make it clear that Korando is solely responsible for cost impacts or delays resulting from their choice to pursue an alternate demolition and construction phasing plan rather than the construction phasing plan provided in the contract drawings.

If you have any questions or need additional information please contact, Mr. Isidro Duarosan, Supervisor, Federal-Aid Highway Construction Section at 649-3104, Mr. Crispin Bengan, Project Engineer, DPW at 649-3115, Mr. Houston Anderson, Construction Manager, Parsons Transportation Group, Inc. at 648-1066 or Mr. Jack Marlowe, Chief Resident Project Representative, Stanley Consultants at 646-3466.

Sincerely,

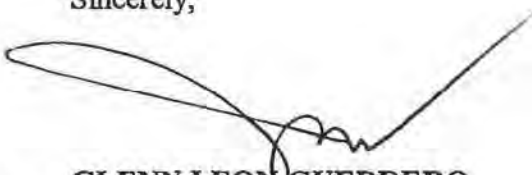

**GLENN LEON GUERRERO**

602.

Attachments: Korando Drawing – Pigua and Bile Bridge Existing Condition, Sheet 3 of 5



Cc: Isidro Duarosan, DPW  
Crispin Bensen, DPW  
Richelle Takara, FHWA  
Jack Marlowe, CM  
Joseph Pecht, PTG  
Derrick Lehman, PTG  
Houston Anderson, PTG

IDuarosan /JBlaz



H



The Honorable  
Eddie Baza Calvo  
Governor

The Honorable  
Ray Tenorio  
Lieutenant Governor



MAY 13 2015

Mr. Byong Ho Kim  
President  
Korando Corporation  
P.O. Box 20538  
GMF, GU 96921

**Ref: Bile/Pigua Bridge Replacement  
Project No. GU-NH-NBIS(007)  
SCHEDULE DELAY - REQUEST FOR EXTENSION OF CONTRACT TIME,  
KORANDO LETTER, DATED APRIL 27, 2015**

Dear Mr. Kim:

The Department of Public Works (DPW) sent a letter to Korando on April 23, 2015 pointing out that Korando is nearly two months behind schedule and instructing Korando to provide a plan for recovery. Korando's April 27<sup>th</sup> letter in response to DPW includes the following statement:

"Please review the attached catch-up schedule attached reckoned that the actual start date can only start after the release of the project required permits dated March 5, 2015 and a letter from Mr. Derrick Lehman, that a copy of DOA's site consultation/meeting needs to be submitted prior to any clearing and grubbing work."

DPW does not understand what this statement means. If the intention of this statement is to request an extension of time, we direct Korando to Section 108.03 of FP-03 which states that only delays or modifications that affect critical activities or cause noncritical activities to become critical will be considered for time extensions. No time extension will be made for delays or modifications that use available float time. Furthermore, any request for an extension of time must include the following:

- (a) Contract clause(s) under which the request is being made.
- (b) Detailed narrative description of the reasons for the requested contract time adjustment including the following:
  - (1) Cause of the impact affecting time;
  - (2) Start date of the impact;
  - (3) Duration of the impact;
  - (4) Activities affected; and
  - (5) Methods to be employed to mitigate the impact.



(c) Suggested new completion date or number of days supported by current and revised construction schedules according to Section 155.

By this letter, DPW instructs Korando to present a cause of delay other than failure to timely perform as contracted or from causes beyond Korando's control and without fault or negligence on the part of the contractor. A claim for delay must conform to the requirements of Section 108.03 as described above. Submittal of cause for delay will not relieve Korando from the contractual requirement to prosecute the work with sufficient diligence. As indicated in prior correspondence, Korando must still furnish a detailed plan to increase production without additional cost to the Government.

Any claim for additional time or compensation is required to be made in the time and manner provided in the parties Contract. Nothing herein is intended to waive any of the Government's rights under the Contract all of which are specifically reserved.

If you have any questions or need additional information, please contact, Mr. Isidro Duarosan, Supervisor, Federal-Aid Highway Construction Section at 649-3104, Mr. Crispin Bengan, Project Engineer, DPW at 649-3115, Mr. Houston Anderson, Construction Manager, Parsons Transportation Group, Inc. at 648-1066 or Mr. Jack Marlowe, Chief Resident Project Representative, Stanley Consultants at 646-3466.

Sincerely,

  
**GLENN LEON GUERRERO**

Attachments: N/A

Cc Isidro Duarosan, DPW  
Crispin Bengan, DPW  
Richelle Takara, FHWA  
Jack Marlowe, CM  
Joseph Pechi, PTG  
Derrick Lehman, PTG  
Houston Anderson, PTG  
Westchester Fire Insurance Company c/o Takagi & Associates, Inc.

  
IDuarosan / JB12z

○

○

7

The Honorable  
Eddie Baza Calvo  
Governor

The Honorable  
Ray Tenorio  
Lieutenant Governor

COPY

public work

Glenn Leon Guerrero

Felix C. Benaven

MAY 20 2015

Mr. Ruel Remetira  
Project Manager  
Korando Corporation  
P.O. Box 20538  
GMF, GU 96921

Korando Corporation  
**RECEIVED**  
DATE: 5/21/15  
Felix C. Benaven

Ref: **Bile/Pigua Bridge Replacement**  
**Project No. GU-NH-NBIS(007)**  
**ELECTRIC CONCRETE PEDESTAL LOCATION AND RESPONSE TO RFI #9**

Dear Mr. Remetira:

Pursuant to Stanley Consultants response to RFI #9 on the issue of the property owner's objection to the planned location at Station 9 + 51.93, Offset 38.13' left, authorization is given to Korando Corporation for relocation of the subject pedestal to an alternate location. This new location, approximately Station 9+37 and 33.1 feet from the house, on the attached marked-up of Drawing E 4.1 would align with the left corner of the owner's house between the existing water and sewer services using the same offset from road centerline. Locate the pedestal to clear the existing sewer lateral. The rerouting of the water service may be required; however any rerouting of water services must first be submitted and approved.

Payment for this work will be under Payment Item 99953-0000 Contingent Sum. The "Contingent Sum" is for unforeseen work, for which an amount is included in the contract documents. Payment method is as described in SCR 109.02 (p) paragraphs 1 thru 8. Maintain daily records of resources used, signed by both the contractor's and the DPW's representative on site. Specific details of the work will be as directed and approved by DPW's Chief Resident Project Representative.

If you have any questions or need additional information, please contact Mr. Isidro Duarosan, Supervisor, Federal-Aid Highway Construction Section at 649-3104, Mr. Crispin Bensen, Project Engineer, DPW at 649-3115, Mr. Houston Anderson, Construction Manager, Parsons Transportation Group, Inc. at 648-1066 or Mr. Jack Marlowe, Chief Resident Project Representative, Stanley Consultants at 646-3466.

Sincerely,

  
GLENN LEON GUERRERO

5



The Honorable  
Eddie Baza Calvo  
Governor

The Honorable  
Ray Tenorio  
Lieutenant Governor

COPY

public works

Glenn Leon Guerrero  
Director

Felix C. Benavente  
Deputy Director

Off Office  
GREG

MEMORANDUM

To: Director, Guam Department of Labor

From: Director, Department of Public Works

Subject: **Guam Administrative Rules and Regulations Failure to Comply  
Bile Pigua Bridge Replacement  
Project No. GU-NH-NBIS(007)**

Received  
MAY 29 2015  
11:45AM  
DOL - Director's Office

Pursuant to 17 GAR Labor Relations, Ch. 17 Temporary Alien Workers, & 49 USC Limitations of Temporary Alien Workers, the Department of Public Works (DPW) hereby notifies the Guam Department of Labor that Korando Corporation has failed to comply with the terms and conditions of the Guam H2B Visa program on the above subject project.

Korando Corporation, beginning April 6, 2015, has failed to comply with 49 USC Limitations of Temporary Alien Workers. Korando Corporation failed to have these workers perform only those job duties listed on the labor certification approved by the Governor. These H2B Visa workers are not performing work that corresponds to the job duties listed on the respective labor certifications for their classifications but are being used to perform duties that would correspond to an unskilled labor classification. Attached are two (2) memos (Memo #1 and Memo #2) prepared by the DPW's construction management consultant showing actual work being performed, certified payrolls, GDOL750 forms, daily reports and labor compliance interviews.

Should you have any questions please contact Mr. Joaquin R. Blaz at 649-3128.

  
GLENN LEON GUERRERO

Attachment: Memo #1 & Memo #2

It Duas/san IBIa/

CC: Isidro Duas/san DPW  
Crispin Bensa DPW  
Rhele Takara, FHWA  
Jack Marlowe, CM  
Joseph Pecht, PTG  
Houston Anderson, PTG  
Korando Corporation  
Westchester Fire Insurance Company c/o Takagi & Associates, Inc.

TN15-0735



The Honorable  
Eddie Baza Calvo  
Governor

The Honorable  
Ray Tenorio  
Lieutenant Governor

COPY

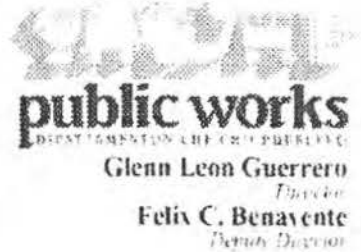

JUN 08 2015

Mr. Byong Ho Kim  
President  
Korando Corporation  
P.O. Box 20538  
GMF, GU 96921

Korando Corporation  
**RECEIVED**  
DATE: 6/8/15  
*Felix C. Benavente*

**Ref: Bile/Pigua Bridge Replacement  
Project No. GU-NH-NBIS(007)  
ELECTRICAL PLAN**

Dear Mr. Kim:

Korando has indicated at meetings and per their submitted schedule that they intend to modify the electrical plan shown on the contract drawings to use underground cable rather than overhead cables and at a different location than shown in the plans.

Korando has been instructed on numerous occasions at progress meetings that a formal request for a change order is required to initiate a change in the scope of the work. The proposed change would be reviewed and if acceptable, a change order would be considered. Korando has not submitted a request for a change order and has proceeded without authorization.

The Department of Public Works (DPW) hereby reminds Korando that they are obligated under contract to perform the work as shown on the plans and specified in the contract. Korando has no authority to make unilateral changes to the contract and should not assume approval for any modifications to the electrical plans. DPW has not authorized changes to the contract with regard to the temporary or permanent electrical plans. Any efforts expended on the non-authorized electrical plans is at Korando's risk and expense and will not be accepted or paid for outside the contract change order process. Therefore, Korando is instructed to perform the work in accordance with the contract, specifications and drawings. Any modification of contract requirements must be through the contract change order process.

If you have any questions or need additional information, please contact, Mr. Isidro Duarosan, Supervisor, Federal-Aid Highway Construction Section at 649-3104, Mr. Crispin Bensen, Project Engineer, DPW at 649-3115, Mr. Houston Anderson, Construction Manager, Parsons Transportation Group, Inc. at 648-1066 or Mr. Jack Marlowe, Chief Resident Project Representative, Stanley Consultants at 646-3466.



*The Honorable*  
**Eddie Baza Calvo**  
*Governor*

*The Honorable*  
**Ray Tenorio**  
*Lieutenant Governor*



**Glenn Leon Guerrero**  
*Director*  
**Felix C. Benavente**  
*Deputy Director*

Mr. Byong Ho Kim  
President  
Korando Corporation  
P.O. Box 20538  
GMF, GU 96921

**Ref: Bile/Pigua Bridge Replacement**  
**Project No. GU-NH-NBIS(007)**  
**ELECTRICAL PLAN**

Dear Mr. Kim:

Korando has indicated at meetings and per their submitted schedule that they intend to modify the electrical plan shown on the contract drawings to use underground cable rather than overhead cables and at a different location than shown in the plans.

Korando has been instructed on numerous occasions at progress meetings that a formal request for a change order is required to initiate a change in the scope of the work. The proposed change would be reviewed and if acceptable, a change order would be considered. Korando has not submitted a request for a change order and has proceeded without authorization.

The Department of Public Works (DPW) hereby reminds Korando that they are obligated under contract to perform the work as shown on the plans and specified in the contract. Korando has no authority to make unilateral changes to the contract and should not assume approval for any modifications to the electrical plans. DPW has not authorized changes to the contract with regard to the temporary or permanent electrical plans. Any efforts expended on the non-authorized electrical plans is at Korando's risk and expense and will not be accepted or paid for outside the contract change order process. Therefore, Korando is instructed to perform the work in accordance with the contract, specifications and drawings. Any modification of contract requirements must be through the contract change order process.

If you have any questions or need additional information, please contact, Mr. Isidro Duarosan, Supervisor, Federal-Aid Highway Construction Section at 649-3104, Mr. Crispin Bensan, Project Engineer, DPW at 649-3115, Mr. Houston Anderson, Construction Manager, Parsons Transportation Group, Inc. at 648-1066 or Mr. Jack Marlowe, Chief Resident Project Representative, Stanley Consultants at 646-3466.



Sincerely,



**GLENN LEON GUERRERO**

Attachments: N/A

Cc: Isidro Duarosan, DPW  
Crispin Bensen, DPW  
Richelle Takara, FHWA  
Jack Marlowe, CM  
Joseph Pecht, PTG  
Derrick Lehman, PTG  
Houston Anderson, PTG



IDuarosan /JBlaz

○

○

2



The Honorable  
Eddie Baza Calvo  
Governor

The Honorable  
Ray Tenorio  
Lieutenant Governor

COPY



Glenn Leon Guerrero  
Director  
Felix C. Benavente  
Deputy Director

June 26, 2015

Mr. Byong Ho Kim  
President  
Korando Corporation  
P.O. Box 20538  
GMF, GU 96921

Korando Corporation  
**RECEIVED**  
DATE: 6/29/2015  
Patsy Jackson  
[Signature]

Ref: **Bile/Pigua Bridge Replacement**  
**Project No. GU-NH-NBIS(007)**  
**NOTICE OF DEFAULT**

Mr. Kim:

This serves to place you on notice that **Korando Corporation** (“Korando”) is in default of the above referenced contract. Specifically, Korando is in breach of the following contract provisions:

1. **Section 108.1 – Commencement, Prosecution and Completion of Work** obligates contractor to “(a) commence work under this contract immediately after the issuance of the **Notice to Proceed**, prosecute the work diligently, ...
2. **Section 108.5 (e)** If the Contractor shall refuse or fail to prosecute the work or any part thereof with such diligence as will insure its completion within the period herein specified ...
3. **Section 108.5 (f)** If the Contractor shall refuse or fail to regard the laws, ordinances or instructions of the Contracting Officer or otherwise be guilty of substantial violations of any provision of the contract, then, in any such event, the Owner, upon receipt of certification from the Contracting Officer justifying that sufficient cause exists, may within 10 calendar days terminate the employment of that Contractor, ...
4. **Section 155.06 – Schedule Updates**, which provides that “Failure of the contractor to maintain the construction schedules and charts will be considered justification for withholding payments.
5. **Formal Contract Article 1 (a) Contract Time.**

6. **Instructions To Bidders Article 11. Time of Completion.**
7. **Notice To Bidders Article 5. Contract Time.**
8. **FP-03 Subsection 107.01 Laws to be Observed.**
9. **FP-03 Subsection 155.01 / FAR Sections 52.236-15 Schedules for Construction Contracts.**
10. **FAR and 52.249-10 Default (Fixed-Price Construction).**
11. **Article I.3 of the Required Contract Provisions (RCP) Federal-Aid Construction Contract.**
12. **Instructions to Bidders Article 25 Termination of Work on Failure to Pay Agreed Wages.**

A number of the above listed breach of contract provisions relate to H2B Temporary Alien Worker limitations; Apprentice Program documentation and reporting; Certified Payroll worker classifications; Certified Payroll reporting; Minimum wage requirements for laborer classification; and Change orders.

The **Department of Public Works ("DPW")** issued the **Notice to Proceed ("NTP")** on **January 5, 2015**. Despite numerous meetings, letters and telephone calls urging Korando to take the action necessary to complete the project on time we estimate that thirty eight percent (38%) of the contract time has expired with only five percent (5%) of the work performed although the work primarily relates to mobilization and establishing a field office. Permanent work on the project is less than one percent (1%) leading us to determine that Korando will exceed the agreed to completion date by one hundred and thirty two (132) days.

In my capacity as Contracting Officer I hereby certify that for the reasons set forth herein sufficient cause exists for terminating the contract. Korando has ***ten (10) calendar days from receipt of this Notice of Default*** to (a) commence meaningful work on the Project; (b) supply enough properly skilled workmen and provide the materials to complete the work within the contract term; (c) to submit ***acceptable*** updated Project schedule; and (d) the other listed defects. The updated Project schedule needs to be realistic and needs to acknowledge delays in performance to date and that Korando is not able to complete the Project in the contracted for time. In this respect, the department has only recently received your June 22, 2015 letter requesting major changes to Project's electrical plan. We do not intend on responding to this letter until the updated Project schedule is received, which we request either reference the electrical plan changes or incorporate them therein. This Notice allows you ten (10) calendar days to cure the failure to diligently perform meaningful work and correct all current breaches of the parties' contract. Unless the failure to perform is cured within the ten (10) calendar days the Contracting Officer may issue a notice of termination for default.

Nothing herein is intended to nor shall be interpreted as waiving or amending Korando's rights and obligations under the contract, all of which are specifically reserved by the Government of Guam.

If you have any questions or need additional information, please contact, Mr. Isidro Duarosan, Supervisor, Federal-Aid Highway Construction Section at 649-3104, Mr. Crispin Bensen, Project Engineer, DPW at 649-3115. Mr. Houston Anderson, Construction Manager, Parsons Transportation Group, Inc. at 648-1066 or Mr. Jack Marlowe, Chief Resident Project Representative, Stanley Consultants at 646-3466.

Sincerely,



**GLENN LEON GUERRERO**

Cc: Isidro Duarosan, DPW  
Crispin Bensen, DPW  
Richelle Takara, FHWA  
Jack Marlowe, CM  
Joseph Pecht, PTG  
Derrick Lehman, PTG  
Houston Anderson, PTG  
Westchester Fire Insurance Company c/o Takagi & Associates, Inc

IDuarosan /JBlaz



m



The Honorable  
Eddie Baza Calvo  
Governor

The Honorable  
Ray Tenorio  
Lieutenant Governor

COPY

JMH GRS  
**public works**  
DIPATTAMENTON CHE'CHO PUPPLEKO  
Glenn Leon Guerrero  
Director  
Felix C. Benavente  
Deputy Director

July 10, 2015

*[Handwritten signature]*  
07-10-15

**VIA FACSIMILE NO. 671/648-5373, HAND DELIVERY  
AND CERTIFIED MAIL**

Mr. H. George Takagi  
President  
Takagi & Associates, Inc.  
Suite 200 Flame Tree Plaza  
540 Pale San Vitores Rd.  
Tumon, Guam 96913

**Re: Bile/Pigua Bridge Replacement  
Project No. GU-NH-NBIS(007)  
Mr. Byong Ho Kim  
Surety: Westchester Fire Insurance Company  
Bond No.: K07901689  
Amount of Bond: \$ 3,665,559.00**

Dear Mr. Takagi:

The Government of Guam, through the Department of Public Works, is submitting this letter as a formal tender of claim against the full amount of the above-referenced Payment and Performance Bond issued by Westchester Fire Insurance Company ("Surety") to Korando Corporation ("Korando"). A copy of the Bond is enclosed.

On or about June 10, 2014, Korando entered into a written Contract with the Government wherein it agreed to perform construction work on what is identified as the *Bile/Pigua Bridge Reconstruction Project* ("Project"). The Project is one that is funded fully by the Federal Highway Administration ("FHWA").

Under the terms of the Contract, the Project is due to be completed within 450 days from the Notice to Proceed, which the Government issued on January 5, 2015. As of the date of this letter, forty one percent (41%) of the contract time has expired with only five percent (5%) of the work being performed, most of which relates to mobilization and establishing a field office. Permanent work on the Project is less than one percent (1%).

In addition to failing to diligently progress and prosecute the work, Korando is in breach of a number of provisions under the Contract.

TN15-0998

TN15-0998



*The Honorable*  
**Eddie Baza Calvo**  
*Governor*

*The Honorable*  
**Ray Tenorio**  
*Lieutenant Governor*



July 10, 2015

**VIA FACSIMILE NO. 671/648-5373, HAND DELIVERY  
AND CERTIFIED MAIL**

Mr. H. George Takagi  
President  
Takagi & Associates, Inc.  
Suite 200 Flame Tree Plaza  
540 Pale San Vitores Rd.  
Tumon, Guam 96913

**Re: Bile/Pigua Bridge Replacement  
Project No. GU-NH-NBIS(007)**  
Mr. Byong Ho Kim  
Surety: Westchester Fire Insurance Company  
Bond No.: K07901689  
Amount of Bond: \$ 3,665,559.00

Dear Mr. Takagi:

The Government of Guam, through the Department of Public Works, is submitting this letter as a formal tender of claim against the full amount of the above-referenced Payment and Performance Bond issued by Westchester Fire Insurance Company ("Surety") to Korando Corporation ("Korando"). A copy of the Bond is enclosed.

On or about June 10, 2014, Korando entered into a written Contract with the Government wherein it agreed to perform construction work on what is identified as the *Bile/Pigua Bridge Reconstruction Project* ("Project"). The Project is one that is funded fully by the Federal Highway Administration ("FHWA").

Under the terms of the Contract, the Project is due to be completed within 450 days from the Notice to Proceed, which the Government issued on January 5, 2015. As of the date of this letter, forty one percent (41%) of the contract time has expired with only five percent (5%) of the work being performed, most of which relates to mobilization and establishing a field office. Permanent work on the Project is less than one percent (1%).

In addition to failing to diligently progress and prosecute the work, Korando is in breach of a number of provisions under the Contract.

Despite a number of opportunities to cure identified deficiencies, Korando has repeatedly displayed bad faith and judgment, thereby casting serious doubt on its competence and ability to continue on in the Project, much less to properly complete it in a timely manner. As a direct consequence of its failure to promptly and faithfully perform its legal obligations, Korando has materially breached the Contract. Korando is in default, and is so declared by the Government to be in default under the Contract. In contrast, the Government has fulfilled all of its contractual obligations.

Because of Korando's non-performance and breaches under the Contract, the Government has exercised its right to immediately terminate the contract with Korando effective July 10, 2015. By this letter, the Government now hereby claims and demands that the Surety immediately commence performing its obligations as set forth and articulated in its Bond No. K07901689. These include the obligation to:

- Promptly remedy the default; or
- Promptly complete the Contract in accordance with its terms and obligations; or
- Obtain a bid or bids for completing the Contract in accordance with its terms and conditions, and upon determination by the Government and the Surety of the lowest responsive and responsible bidder, arrange for a contract between such bidder and the Government. Make available as work progresses, sufficient funds to pay the cost of completion less the balance of the Contract price, but not exceeding, including other costs and damages for which the Surety may be liable.

At all times, the Government expressly reserves the right to supplement this letter and this claim by furnishing one or more supplemental notices or proofs of loss as the appalling details of Korando's defective and substandard performance continue to be discovered.

The failure of Korando to prosecute construction of the Project has resulted in such a dire extent that the situation warrants emergency measures. Time is of the essence in the performance of the Surety's obligations. Accordingly, it is requested that the parties personally meet as soon as possible and in no event later than three (3) business days receipt of this letter to further discuss this matter. Please call me at 646-3131, or Joaquin Blaz at 649-3128, to schedule a time and date for our meeting.

Thank you for your prompt attention to this matter.

Sincerely,



Glenn Leon Guerrero



Cc: Attorney General of Guam  
Richelle Takara, Territorial Representative, FHWA



**PERFORMANCE AND PAYMENT BONDS**

BOND #: K07901689

KNOW ALL MEN BY THESE PRESENTS that

KORANDO CORPORATION

(Name of Contractor)

hereinafter called the Contractor and

WESTCHESTER FIRE INSURANCE COMPANY

(Name of Surety)

a corporation duly organized under the laws of the State of PENNSYLVANIA and authorized to transact business in the Territory of Guam, as Surety, are held and firmly bound unto the Government of Guam, as obligee, hereinafter called the Government for use and benefit of claimants as herein below defined, in the amount of **\*\* THREE MILLION SIX HUNDRED SIXTY FIVE \*\*** (\$,665,559.00) for the payment whereof the Contractor and Surety bind themselves, their heirs, executors, administrators, successors and assigns, jointly and severally, firmly by these presents.

**\*\* THOUSAND FIVE HUNDRED FIFTY NINE AND NO/100 \*\*\*\*\* \$3,665,559.00.**

WHEREAS, the Contractor has by written Agreement dated \_\_\_\_\_, 20\_\_\_\_, entered into a Contract with the Government of Guam for the **BILE / PIGUA BRIDGE REPLACEMENT (CONSTRUCTION PHASE), PROJECT NO.: GU-NH-NBIS(007)**, in accordance with drawings, Specifications and documents prepared by the Department of Public Works, which Contract is by reference made a part hereof, and is hereinafter referred to as the Contract.

NOW, THEREFORE, THE CONDITION OF THIS OBLIGATION is such that, if the Contractor shall promptly and faithfully perform said Contract, and shall promptly make payment to all claimants as hereinafter defined for all labor and material used or reasonably required for use in the performance of the Contract, then this obligation shall be null and void; otherwise it shall remain in full force and effect, subject, however, to the following conditions:

- A. The Surety hereby waives notice of any alteration or extension of the time made by the Government provided the same is within the scope of the Contract.
- B. Whenever Contractor shall be and is declared by the Government to be in default under the Contract, the Government having performed territorial obligations thereunder, the Surety may promptly remedy the default or shall promptly:
  1. Complete the Contract in accordance with its terms and conditions; or
  2. Obtain a bid or bids for completing the Contract in accordance with its terms and conditions, and upon determination by the Government and the Surety of the lowest responsive, responsible bidder, arrange for a Contract between such bidder and the Government, and make available as work progresses (even though there should be a default or a succession of defaults under the Contract or Contracts of completion arranged under this paragraph) sufficient funds to pay the cost of completion less than



*Bile / Pigua Bridge Replacement (Construction Phase)  
Project No.: GU-NH-NBIS(007)*

balance of the Contract price, but not exceeding, including other costs and damages for which the Surety may be liable hereunder, the amount set forth in the first paragraph hereof. The term "balance of the Contract price", as used in this paragraph shall mean the total amount payable by the Government to Contractor under the Contract and any amendments thereto, less the amount properly paid by the Government to Contractor. No right of action shall accrue on this bond to or for the use of any person or corporation other than the Government or successors of the Government.

- C. A claimant is defined as one having a direct contract with the Contractor or with a sub-contractor of the Contractor for labor, material, or both, used or reasonably required for use in the performance of the Contract, labor and material being construed to include that part of water, gas, power, light, heat, oil, gasoline, telephone service or rental of equipment directly applicable to the Contract.
- D. The above-named Contractor and Surety hereby jointly and severally agree with the Government that every claimant as herein defined, who has not been paid in full before the expiration of a period of ninety (90) days after the date on which the last of such claimant's work or labor was done or performed, or materials were furnished by such claimant, may sue on this bond for use of such claimant, prosecute the suit to final judgment for such sum or sums as may be justly due claimant, and have execution thereon. The Government shall not be liable for the payment of any costs or expenses of any such suit.
- E. No suit or action shall be commenced hereunder by any claimant:
1. Unless claimant, other than one having a direct contract with the Contractor, shall have given written notice to any two of the following:  
  
The Contractor, the Government, or the Surety above named, within ninety (90) days after such claimant did or performed the last of the work or labor, or furnished the last of the materials for which said claim is made, stating with substantial accuracy the amount claimed and the name of the party to whom the materials were furnished, or for whom the work or labor was done or performed. Such notice shall be personally served by mailing the same by registered mail or certified mail, postage prepaid, in an envelope addressed to the Contractor at any place the principal maintains an office or conducts its business.
  2. After the expiration of one (1) year following the date on which the last of the labor was performed or material was supplied by the party bringing suit.
  3. Other than in a court of competent jurisdiction in and for the Territory of Guam.
- F. The amount of the payment bond shall be reduced equivalent to the extent of any payment(s) made in good faith hereunder, inclusive of the payment by the Surety of mechanic's liens which may be filed on record against said improvement, whether or not claim for the amount of such lien be presented under and against this bond.

Bile / Pigua Bridge Replacement (Construction Phase)  
Project No.: GU-NH-NBIS(007)

SIGNED AND SEALED THIS 25TH day of MARCH, 2014, A.D.

IN THE PRESENCE OF:

(Note: If the Principals are Partners, each must execute the Bond)

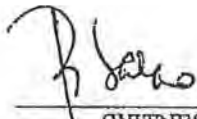
  
\_\_\_\_\_  
(WITNESS)

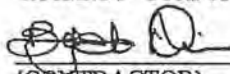
KORANDO CORPORATION  
  
\_\_\_\_\_  
(CONTRACTOR) (SEAL)

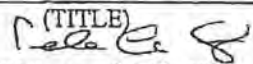
\_\_\_\_\_  
(TITLE)  
  
PAMELA A. CRUZ FOR  
STEPHEN M. HANEY  
\_\_\_\_\_  
(MAJOR OFFICER OF SURETY)

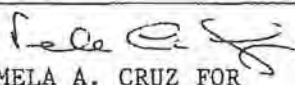
\_\_\_\_\_  
  
PAMELA A. CRUZ FOR  
WILLIAM L. KELLY  
\_\_\_\_\_  
(MAJOR OFFICER OF SURETY)

VICE PRESIDENT  
\_\_\_\_\_  
(TITLE)

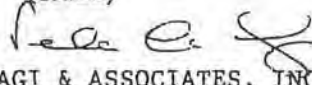
ASSISTANT SECRETARY  
\_\_\_\_\_  
(TITLE)  
  
TAKAGI & ASSOCIATES, INC.  
\_\_\_\_\_  
(RESIDENT GENERAL AGENT)

# Power of Attorney

## WESTCHESTER FIRE INSURANCE COMPANY

Know all men by these presents; That WESTCHESTER FIRE INSURANCE COMPANY, a corporation of the Commonwealth of Pennsylvania pursuant to the following Resolution, adopted by the Board of Directors of the said Company on December 11, 2006, to wit:

"RESOLVED, that the following authorizations relate to the execution, for and on behalf of the Company, of bonds, undertakings, recognizances, contracts and other written commitments of the Company entered into in the ordinary course of business (each a "Written Commitment")

- (1) Each of the Chairman, the President and the Vice Presidents of the Company is hereby authorized to execute any Written Commitment for and on behalf of the Company, under the seal of the Company or otherwise.
- (2) Each duly appointed attorney-in-fact of the Company is hereby authorized to execute any Written Commitment for and on behalf of the Company, under the seal of the Company or otherwise, to the extent that such action is authorized by the grant of powers provided for in such persons written appointment as such attorney-in-fact.
- (3) Each of the Chairman, the President and the Vice Presidents of the Company is hereby authorized, for and on behalf of the Company, to appoint in writing any person the attorney-in-fact of the Company with full power and authority to execute, for and on behalf of the Company, under the seal of the Company or otherwise, such Written Commitments of the Company as may be specified in such written appointment, which specification may be by general type or class of Written Commitments or by specification of one or more particular Written Commitments.
- (4) Each of the Chairman, the President and Vice Presidents of the Company is hereby authorized, for and on behalf of the Company, to delegate in writing any other officer of the Company the authority to execute, for and on behalf of the Company, under the Company's seal or otherwise, such Written Commitments of the Company as are specified in such written delegation, which specification may be by general type or class of Written Commitments or by specification of one or more particular Written Commitments.
- (5) The signature of any officer or other person executing any Written Commitment or appointment or delegation pursuant to this Resolution, and the seal of the Company, may be affixed by facsimile on such Written Commitment or written appointment or delegation.

FURTHER RESOLVED, that the foregoing Resolution shall not be deemed to be an exclusive statement of the powers and authority of officers, employees and other persons to act for and on behalf of the Company, and such Resolution shall not limit or otherwise affect the exercise of any such power or authority otherwise validly granted or vested.

Does hereby nominate, constitute and appoint BARBARA C SALAS, HIDENOBU TAKAGI, JOSEPH C BARCINAS, PAMELA A CRUZ, all of the City of TUMON, Guam, each individually if there be more than one named, its true and lawful attorney-in-fact, to make, execute, seal and deliver on its behalf, and as its act and deed any and all bonds, undertakings, recognizances, contracts and other writings in the nature thereof, in penalties not exceeding Five million dollars & zero cents (\$5,000,000.00) and the execution of such writings in pursuance of these presents shall be as binding upon said Company, as fully and amply as if they had been duly executed and acknowledged by the regularly elected officers of the Company at its principal office,

IN WITNESS WHEREOF, the said Stephen M Haney, Vice-President, has hereunto subscribed his name and affixed the Corporate seal of the said WESTCHESTER FIRE INSURANCE COMPANY this 25 day of February 2014

WESTCHESTER FIRE INSURANCE COMPANY



*Stephen M Haney*  
Stephen M Haney, Vice President

COMMONWEALTH OF PENNSYLVANIA  
COUNTY OF PHILADELPHIA

ss.

On this 25 day of February, A.D. 2014 before me, a Notary Public of the Commonwealth of Pennsylvania in and for the County of Philadelphia came Stephen M. Haney, Vice-President of the WESTCHESTER FIRE INSURANCE COMPANY to me personally known to be the individual and officer who executed the preceding instrument, and he acknowledged that he executed the same, and that the seal affixed to the preceding instrument is the corporate seal of said Company, that the said corporate seal and his signature were duly affixed by the authority and direction of the said corporation, and that Resolution, adopted by the Board of Directors of said Company, referred to in the preceding instrument, is now in force.

IN TESTIMONY WHEREOF, I have hereunto set my hand and affixed my official seal at the City of Philadelphia the day and year first above written.



*Karen E Brandt*  
Notary Public

I, the undersigned Assistant Secretary of the WESTCHESTER FIRE INSURANCE COMPANY, do hereby certify that the original POWER OF ATTORNEY, of which the foregoing is a substantially true and correct copy, is in full force and effect.

In witness whereof, I have hereunto subscribed my name as Assistant Secretary, and affixed the corporate seal of the Corporation, this 25<sup>th</sup> day of MARCH, 2014.



*William J. Kelly*  
William J. Kelly, Assistant Secretary

THIS POWER OF ATTORNEY MAY NOT BE USED TO EXECUTE ANY BOND WITH AN INCEPTION DATE AFTER February 25, 2016



GOVERNMENT OF GUAM  
DEPARTMENT OF REVENUE AND TAXATION  
OFFICE OF THE INSURANCE COMMISSIONER  
**CERTIFICATE OF AUTHORITY**

RENEWAL

#284

*Know All Men By These Presents That:*

*Name* WESTCHESTER FIRE INSURANCE COMPANY

*Address* 436 WALNUT STREET  
PHILADELPHIA

PA 19106

*Classes of Insurance  
Authorized*

} ACCIDENT & HEALTH  
FIDELITY & SURETY  
FIRE  
MARINE

MISCELLANEOUS  
MOTOR VEHICLE  
PROP. DAMAGE & LIABILITY  
WORKMENS COMP

*Having complied with the Insurance Law of Guam, is hereby authorized to transact as an insurer, the above named Classes of Insurance in Guam from the 01 day of July, 20 13, to the 01 day of July, 20 14, unless authority is revoked for failure to comply with the law.*

**General Agent(s):**

TAKAGI & ASSOCIATES INC  
CASSIDY'S ASSOCIATED INSURERS INC

*In Witness Whereof, I have hereunto subscribed my name officially and have hereon impressed my Seal of Office at the City of Hagatña, Guam on this 30 day of July A.D. 20 13.*

*Artemio B. Ilagan*  
ARTEMIO B. ILAGAN  
Insurance Commissioner

2



gksp



# Department of Agriculture Dipattamenton Agrikottura

163 Dairy Road, Mangilao, Guam 96913



Edward J.B. Calvo  
Governor  
Raymond S. Tenorio  
Lt. Governor

Director's Office  
Agricultural Dev. Services  
Animal Health  
Aquatic & Wildlife Resources  
Forestry & Soil Resources  
Plant Nursery  
Plant Inspection Facility

300-7966/64; Fax 734-6569  
300-7973/300-7967  
300-7965  
735-3955/56; Fax 734-6570  
300-7976; Fax 300-3201  
300-7974  
475-1426/27; Fax 477-9487

Mariquita F. Taitague  
Director  
Matthew L.G. Sablan  
Deputy Director

July 25, 2014

Korando Corporation  
POB 20538  
GMF, Guam 96921  
671-649-7880

**Subject: Bile and Pigua replacement (construction phase) project.  
GU-NH-NBIS (007).**

The Division of Aquatic and Wildlife Resources (DAWR) reviewed the plans for the proposed Bile and Pigua Bridge replacement project located in Malesso. Both existing bridges contain structural damage in need for repair to ensure a complete, usable and safe facility. The project consists of the demolition of the existing structure, removal of the debris, and reconstruction of the bridges with an increased span to widen the existing river opening at the bridges.

Listed are concerns and issues that will need to be addressed:

1. The sedimentation control at the project site must be monitored on a daily basis. Silt curtains will need to be reinforced or strengthened nearest to the river.
2. The Contractor be required to develop a bio-security plan to prevent the spread of invasive species to and from the site. Of most concern is the spread of the Little fire ant (*Wasmannia auropunctatata*). The contractor is required to consult with the Department of Agriculture's Plant Inspection Facility or the University of Guam's College of Natural and Agricultural Science's Entomology Department to seek guidance to develop such plan.
3. The Plans provided by the Contractor fails to identify a staging area at the proposed project sites. The Contractor is responsible to identify a staging area that will have less significant impact or avoid having any impact to the adjacent habitats at the project site. The Contractor is required to submit an

amendment to the proposed plans for the staging area for an environment consultation.

4. The Contractor is required to remove constructional debris that enters the river.
5. Night hours are allowed with the exception of lights to be facing inland and not out to the shore.
6. Migratory birds foraging or wading at the river mouth should not be disturbed or harassed by any means. Allow for the birds to leave the site on their volition. Migratory birds are Federally protected under the Migratory Bird Treaty Act of 1917.
7. There shouldn't be any vegetation clearing. If so needed, DAWR must be contacted immediately to get clearance.
8. Dust control must be implemented throughout the duration of the project.
9. The Contractor is responsible to monitor machinery used at the site for any hydraulic leaks. Absorbent pads should be readily available for spills.

This environmental consultation consists of the review of the proposed project and conditions as listed above to be implemented in duration of the project to avoid or minimize impacts at both project sites.

If you have any questions or concerns to the environmental consultation please address them to Mr. Jeff Quitugua at the 735-3955/6 or via email at [jeff.quitugua@yahoo.com](mailto:jeff.quitugua@yahoo.com).

Sincerely,

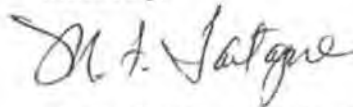

**MARIQUITA F. TAITAGUE**

0



SM  
G/SP



# GUAM ENVIRONMENTAL PROTECTION AGENCY

AHENSIAN PRUTEKSION LINA'LA GUAHAN

EDDIE BAZA CALVO  
GOVERNOR OF GUAM

RAY TENORIO  
LT. GOVERNOR OF GUAM

ERIC M. PALACIOS  
ADMINISTRATOR, GUAM EPA, ENERGY OFFICE

P.O. Box 22439 BARRIGADA, GU 96921

EPA.GUAM.GOV

Mr. Byong Ho Kim  
President  
KORANDO Corporation  
P.O. Box 20538  
GMF, Guam 96921

AUG 29 2014

Ref: Demolition of Existing Bile & Pigua Bridges and Construct 2-Lane Bridge

Hafa Adai Mr. Kim,

Guam EPA has conditionally approved your building permit clearance for the above reference project with the following conditions:

1. You must submit a Water Monitoring Plan for GEPA's review and approval prior to commencement of any work underwater or at the bridge for conformance with the approved 401 Water Quality Certification.
2. You must submit a Solid Waste Disposal Permit application for GEPA's review and approval prior to commencing any demolition or construction work (see attached form).
3. Install BMPs, if needed to prevent sediments and/or storm water run-off flowing into the water that comes from your in-land staging or equipment parking area. Request inspection from GEPA, WPC program upon installation.
4. You must submit a copy of the SWPPP/NOI and kept copy at the job site for future reference.

Should you have questions please contact me at 300-4796 or Johnny Abedania @ 300-4786 or email me at [angel.marquez@epa.guam.gov](mailto:angel.marquez@epa.guam.gov).

Sincerely,

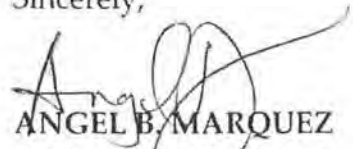
  
ANGEL B. MARQUEZ  
Acting Chief Engineer

CC: Director, DPW





a

# Exhibit a

# **Korando Correspondence**

Dated April 15, 2015

Memo to Mr. Glenn Leon Guerrero

from Byong Ho Kim

Re: Schedule Delay-Response to DPW Letter



**KORANDO CORPORATION**  
**GENERAL CONTRACTOR**

P.O. BOX 20536  
GMF, GUAM 96921  
TEL: (671) 649-7880  
(671) 649-7881  
FAX: (671) 649-7882  
EMAIL: admin\_korando@teleguam.net

TH16-0528

dmh Gmsp

April 15, 2015

To : Mr. Glenn Leon Guerrero  
DPW

Subject : Schedule Delay – Response to DPW Letter



Dear Mr. Guerrero,

Korando Corporation was also concerned on delays that was created by unforeseen activities that we encounter during site actual activities analyses. It was found out that due to limited work space or the Area of Potential Effect (APE) the baseline derived was not realistic and also because of the following reasons:

1. The staging area was not included in the contract but very important because of the narrow space at project area for the materials laydown area and equipment staging area. Korando understand that the staging area requirements per contract was Korando's responsibility in terms of rentals and other permitting but did not expect that the Archaeological works take long and that expensive.
2. Pile driving activities should mobilized and start once overhead electrical primary lines has been relocated. GPA has just review and forward to us their recommendations.
3. Equipment for pile driving will set two days and test pile driving is one day, once the desired pile length is determine, fabrication of the remaining piles shall follows with a high early strength concrete. This apply to Bile and Pigua bridge area.
4. The alternate phasing plan has been derived to consider the one time pile driving equipment mobilization. The construction of temporary steel bridge is also incorporated in the proposed phasing plan and it has a design to carry load for it is also be use as crane access.
5. Utility relocation was also revised in accordance with the proposed phasing plan. The electrical and communication line will be relocated at the mountain side and water line still on the seaside.
6. Korando will revised and recovery schedule for the pile driving showing the original design which is to determine required pile length and proceed fabrication of the rest of the piles once the length is derived.

7. Korando will request a time extension for the Archaeological works for staging area cause delays in which the contract between IARII has been agreed last January 20, 2015 but until now is not yet completed. They instruct to refrain any excavation works while waiting SHPO final archaeological report approval.
8. Other administrative requirements such as GEPA Water Quality Monitoring Plan and Department of Agriculture site orientation has been done on March 05, 2015.

Korando will conduct a thorough study to derive a realistic project recovery schedule and to be submitted to Stanley Consultant for review and approval.

Very Respectfully,

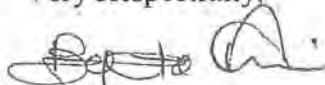

Byong Ho Kim  
President



6

# Exhibit b



# **Korando Correspondence**

Dated April 27, 2015  
DPW Letter Dated April 23, 2015  
Schedule Delay-Response



**KORANDO CORPORATION**  
**GENERAL CONTRACTOR**

*dmh GASP*

P.O. BOX 20538  
 GMF, GUAM 96921  
 TEL: (671) 649-7880  
 (671) 649-7881  
 FAX: (671) 649-7882  
 EMAIL: admin\_korando@teleguam.net

April 27, 2015

Glenn Leon Guerrero  
 Director  
 Department of Public Works  
 542 North Marine Corps Drive  
 Tamuning, Guam 96913



Project: Bile/Pigua Bridge Replacement  
 GU-NH-NBIS(007)

Subject: DPW Letter Dated April 23, 2015  
 Schedule Delay - Response

Dear Glenn Leon Guerrero:

Respectfully, subject DPW response to Korando Corporation's dated April 23, 2015 letter, we wish to present to you the events that surrounded this project;

1) ON THE SCHEDULE

1.1 Building Permit

NTP for this project was released	January 5, 2015
Actual & fully executed building permit was released	March 5, 2015

Attached is the flow of when each concern agency signed & approved the permit application as a requirements for the project to start. Because of this, the project could have not started January 2015 as mentioned in our last meeting on April 15, 2015. And, consequently, this flow of building permit approval has been capture in the various meeting.

But this account, with the release/clearance of the building permit only March 5, 2015, this should be the reckoning date of the contract start of work and this brings us to 15 days of delay to this writing.

1.2 Catch-up schedule

After our April 15, 2015 meeting, Korando Corporation submitted a catch-up schedule, not given credence by DPW April 23, 2015.

We are resubmitting a catch-up schedule together with this letter for your use. This schedule is further revised to capture the last email communication with Government consultant.



**KORANDO CORPORATION**  
**GENERAL CONTRACTOR**

P.O. BOX 20538  
 GMF, GUAM 96921  
 TEL: (671) 649-7880  
 (671) 649-7881  
 FAX: (671) 649-7882

EMAIL: admin\_korando@teleguam.net

April 27, 2015

Glenn Leon Guerrero  
 Director  
 Department of Public Works  
 542 North Marine Corps Drive  
 Tamuning, Guam 96913

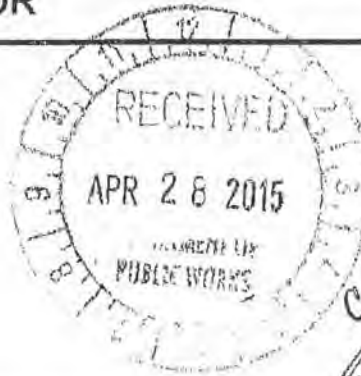

Project: Bile/Pigua Bridge Replacement  
 GU-NH-NBIS(007)

Subject: DPW Letter Dated April 23, 2015  
 Schedule Delay - Response

Dear Glenn Leon Guerrero:

Respectfully, subject DPW response to Korando Corporation's dated April 23, 2015 letter, we wish to present to you the events that surrounded this project;

1) ON THE SCHEDULE

1.1 Building Permit

NTP for this project was released	January 5, 2015
Actual & fully executed building permit was released	March 5, 2015

Attached is the flow of when each concern agency signed & approved the permit application as a requirements for the project to start. Because of this, the project could have not started January 2015 as mentioned in our last meeting on April 15, 2015. And, consequently, this flow of building permit approval has been capture in the various meeting.

But this account, with the release/clearance of the building permit only March 5, 2015, this should be the reckoning date of the contract start of work and this brings us to 15 days of delay to this writing.

1.2 Catch-up schedule

After our April 15, 2015 meeting, Korando Corporation submitted a catch-up schedule, not given credence by DPW April 23, 2015.

We are resubmitting a catch-up schedule together with this letter for your use. This schedule is further revised to capture the last email communication with Government consultant.





**KORANDO CORPORATION**  
**GENERAL CONTRACTOR**

P.O. BOX 20538  
 GMF, GUAM 96921  
 TEL: (671) 649-7880  
 (671) 649-7881  
 FAX: (671) 649-7882  
 EMAIL: admin\_korando@teleguam.net

2) On NO ACTION taken by the contractor before NTP.

This is a mis-representation/information against Korando Corporation.  
 Please find attached the actions taken by Korando Corporation as early as October 2014.

Action/Document Submitted	Date Submitted	Date of Government Action
1. Bile/Pigua Survey Data	10/20/2014	11/14/14 (EAN)
2. Construction Phasing Plan	10/27/2014	11/4/14 (EAN) 3/1/2015 (REVR)
3. EPP & ECP	11/25/2014	1/8/2015 (REVR)
4. Water Quality Monitoring Plan	12/22/2014	1/8/2015 (REVR)
5. SWPPP	12/24/2014	1/8/2015 (EAN)

3) On the proposed staging area

Korando Corporation, upon reviewing of the plans, have noticed that the proposed area is not sufficient for staging purposes. This has been relayed early on and captured in the project meeting minutes. (See attached minutes)

Also, the SCR 107.10(c)(5) mentioned in DPW letter deals on issue that is totally different and not on staging area or archeological monitoring outside APE, see attached project SCR 107.10(c)(5).

Korando Corporation took the initiative & expense to solve the issue of staging area & what we are only requesting is for the government acknowledged the time associated in this effort since this has been put on the table early on in project meetings.

Regardless, with the government view on the staging area, we will abide by the logic that the contractor should have not initiated any kind of effort without putting an appropriate RFI.

Please review the attached catch-up schedule attached reckoned that the actual start date can only start after the release of the project required permits dated March 5, 2015 and a letter from Mr. Derrick Lehman, that a copy of DOA's site consultation/meeting needs to be submitted prior to any clearing and grubbing work.

Sincerely,

Byong Ho Kim  
 President

**Transmittal/Review/Approval**

FILE NAME:

DATE:

Letter Response to DPW Letter Dated April 23, 2015

4/27/2015

CONTRACT NO.: GU-NH-NBIS(007)	TITLE: (Fill in Project Title/Location Here) Bile / Pigua Bridge Replacement (Construction Phase), Route 4, Merizo, Guam		
FROM (CONTRACTOR): Korando Corporation	TO: Dir. Glenn Leon Guerrero / DPW	SUBMITTAL NO.:	SPECS. SECTION:

ENCL. NO.	NO. OF COPIES	DESCRIPTION	SPEC.SEC./PARA	SCHEDULE ACTIVITY NO.	CQC CODE
		Bile & Pigua Bridge Replacement (Construction Phase)			
1	2	Letter Response to DPW Letter Dated April 23, 2015			
2	21	Attached Supporting Documents			

DATE NEEDED BY:

TRANSMITTED FOR:  APPROVAL  CLARIFICATION  SELECTION  RECORD  VARIANCE

*It is hereby certified that the material submitted herein conforms to contract requirements and can be installed in the allocated spaces.*

CONTRACTOR'S REPRESENTATIVE NAME/TITLE Ruel Remetira / Korando	SIGNATURE: 
---	--

Received By (Print Name & Sign)/Date/Time: Dir. Glenn Leon Guerrero / DPW 4/27/2015

FROM:	SIGNATURE:	DATE:
-------	------------	-------

TO: Jack Marlowe / Stanley Consultants	<i>For review/comment ( ) copies of enclosures forwarded. RETURN WITHIN ( ) WORKING DAYS, unless submittal is for record/info purposes only and there are no adverse comments.</i>
---	--

Received By (Print Name & Sign)/Date/Time: Dir. Glenn Leon Guerrero / DPW 4/27/2015

FROM:	TO:	DATE:
-------	-----	-------

RECOMMEND / Enclosure(s) is (are):

<input type="checkbox"/> No Exception Taken (NET)	<input type="checkbox"/> Rejected/Resubmit (Rej/R)	<input type="checkbox"/> _____
<input type="checkbox"/> Exceptions As Noted (EAN)	<input type="checkbox"/> No Action Required (NAR)	<input type="checkbox"/> _____
<input type="checkbox"/> Revise/Resubmit (Rev/R)	<input type="checkbox"/> Not Subject To Review (NSTR)	

REMARKS:

Copies of encls returned: \_\_\_\_\_ SIGNATURE: \_\_\_\_\_

Copy to: \_\_\_\_\_

Received By (Print Name & Sign)/Date/Time:



Government Agencies Permits Requirement to Comply  
- Prior to any Site Work may Proceed

<u>Submittals</u>	<u>Date Submitted/Re-Submitted</u>	<u>Date Response</u>
NTP	- January 5, 2015 -	January 8, 2015
Encroachment Permit	- January 7, 2015 -	January 8, 2015
HACCP (Dept. of Agriculture)	- February 18, 2015 -	March 4, 2015
GEPA Disposal Plan	- February 5, 2015 -	February 18, 2015
GEPA Water Qual. Mon. Plan	- February 18, 2015 -	February 26, 2015
EPP & ECP	- February 4, 2015 -	February 26, 2015
DOA & GWA Site Consultation/Orientation (Done March 5, 2015)	March 30, 2015 -	April 15, 2015

**FILE** MESSAGE

Ignore Delete Reply Reply All Forward Quick Steps Move Mark Unread Follow Up Translate Zoom

Delete Respond Quick Steps Move Tags Editing Zoom



Thu 3/19/2015 4:19 PM  
 Lehman, Derrick <Derrick.Lehman@parsons.com>  
 BILE/PIGUA - Clearing and Grubbing Work

To Ruel Remetira (ruel.remetira@gmail.com); Francisco "Joni" Palma Jr. (joni\_korando@teleguam.net); Nats Catolos (ngcatolos.bbr@teleguam.net)  
 Cc Marlowe, Jack; Senecal, Richard; Richards, Chelsea; Pecht, Joseph; Crispin B. Bensen (crispin.bensen@dpw.guam.gov); Lehman, Derrick; Bonsembiante, Herna Meno, Ed; Anderson, Buster

Ruel, Joni, & Nats,

I just wanted to reiterate from our meeting on Tuesday 3/17 that a copy of DOA's site consultation/meeting needs to needs to be submitted prior to any clearing and grubbing work.

Please also be mindful that Korando does not have authorization to employ H2B workers on the project. If Korando foresees the need of H2B's please submit your required documents ASAP.

If you have any questions please contact Stanley or myself.

Thanks & Regards,

Derrick

Derrick Lehman  
 Parsons  
 Parsons Transportation Group Inc.  
 590 South Marine Corps Drive ITC Building, Ste 403 | Tamuning, Guam 96913  
 671-648-1076 (Office)  
 671-977-0237 (Cell)  
 671-646-0678 (Fax)  
[www.parsons.com](http://www.parsons.com)





## MEETING MINUTES

Meeting Notes No. 001

Meeting: Weekly Construction Meeting  
 Project: Bile/Pigua Bridge Replacement  
 Job#: GU-NH-NBIS(007)  
 Meeting Location: SCI Conference Room

Date: January 13, 2014  
 Time: 2:00 p.m.  
 Next Meeting Location: SCI Conference Room  
 Next Meeting: January 27, 2014 @ 2pm

Denotes Attendance     Denotes Partial Attendance

	<u>Name</u>	<u>Company</u>	<u>Email</u>	<u>Phone</u>
X	Jack Marlowe	SCI	<a href="mailto:marlowejack@stanleygroup.com">marlowejack@stanleygroup.com</a>	
X	Hernan Bonsembiante	SCI	<a href="mailto:bonsembiantehernan@stanleygroup.com">bonsembiantehernan@stanleygroup.com</a>	
X	Joe Pecht	PTG	<a href="mailto:joseph.pecht@parsons.com">joseph.pecht@parsons.com</a>	
X	Derrick Lehman	PTG	<a href="mailto:derrick.lehman@parsons.com">derrick.lehman@parsons.com</a>	
X	Buster Anderson	PTG	<a href="mailto:houston.anderson@parsons.com">houston.anderson@parsons.com</a>	
X	Ruel Remetira	Korando	<a href="mailto:ruel.remetira@gmail.com">ruel.remetira@gmail.com</a>	
X	Ricarte Bisquera	Korando	<a href="mailto:enqr_korando@teleguam.net">enqr_korando@teleguam.net</a>	
X	Francisco "Joni" Palma Jr.	Korando	<a href="mailto:joni_korando@teleguam.net">joni_korando@teleguam.net</a>	
	Nats Catolos	BBRMC	<a href="mailto:nqcatolos.bbr@teleguam.net">nqcatolos.bbr@teleguam.net</a>	
X	Joepeter Gacutan	BBRMC	<a href="mailto:bbrmcjagacutan@aim.com">bbrmcjagacutan@aim.com</a>	
	Crispin Bengan	DPW	<a href="mailto:crispin.bengan@dpw.guam.gov">crispin.bengan@dpw.guam.gov</a>	

### AGENDA

1. SCHEDULE
2. COST STATUS
3. CHANGE ORDERS
4. SUBMITTALS
5. RFI'S
6. REPORTS
7. SAFETY/TRAFFIC CONTROL
8. QUALITY CONTROL
9. ENVIRONMENTAL
10. OPEN ISSUES
11. NEW ISSUES

### ATTACHMENTS

1. MTG ATTENDANCE SHEET
2. KORANDO LOOK-AHEAD
3. COST STATUS LOG-NA
4. CHANGE ORDER LOG-NA
5. SUBMITTAL LOG
6. RFI LOG-NA
7. REPORTS LOG-NA



MEETING NOTES:

**1 SCHEDULE**

**1.1 Summary**

Notice to Proceed:	January 5, 2015
Time for Completion:	450 Calendar Days
Contract Completion Date:	March 29, 2016
Current Scheduled Contract Completion Date:	
Delay:	0
Elapsed Time:	9 Days
Percent Complete:	0.0%

**1.2 Schedule Overview**

- Korando to submit 3 week look ahead for each meeting. (Submitted after the meeting.)
- Korando submitted schedule dated 1/12/15 was discussed
  - A1220 Start Construction - Jan 25
  - A1250 Implement Traffic Control - Jan 25
  - A1255 Clearing and Grubbing - Start Feb 4. CM said Korando needs to arrange for Guam EPA and DOA to visit site and review area to be cleared and proposed mitigation measures prior to clearing operations.
  - A1280 Construction of Staging and Precast Girder Fabrication Area - Start Feb 16.
  - A1720 Provide and Install Temporary Traffic Control for Phase 1 - Start Feb 13.

**ACTION REQUIRED**

Korando



	<u><b>ACTION REQUIRED</b></u>
<p><b>1.3 Potential Delays/Critical Issues</b></p> <ul style="list-style-type: none"> <li>• Work on the staging area (A1280) will be delayed pending preparation and approval of an archaeological monitoring plan. Korando indicates 78 days of float. They do not foresee any delay to project completion.</li> </ul>	
<p><b>2 COST STATUS</b></p> <ul style="list-style-type: none"> <li>• Cost Status Log (N/A)</li> <li>• CM asked if Korando would submit a January invoice. They can collect payment for Mobilization and the Field Office (if accepted).</li> <li>• Korando questioned the CM response to their Schedule of Values. CM said that LS items must be measured/paid in the manner prescribed by the contract. The contract requirements were stated in the CM response.</li> </ul>	
<p><b>3 CHANGE ORDERS</b></p> <ul style="list-style-type: none"> <li>• Change Order Log (N/A)</li> <li>• None</li> </ul>	
<p><b>4 SUBMITTALS</b></p> <ul style="list-style-type: none"> <li>• Submittal Log (attached)</li> <li>• Korando needs to submit subcontracts for approval. Subcontracts must include sections of prime contract as stated in the Required Contract Provisions (RCP) section of the contract.</li> <li>• Submit the e-file with the schedule submittals.</li> </ul>	



	<u>ACTION REQUIRED</u>
<p><b>5 REQUESTS FOR INFORMATION</b></p> <ul style="list-style-type: none"> <li>• RFI Log (N/A)</li> <li>• None</li> </ul>	
<p><b>6 REPORTS</b></p> <ul style="list-style-type: none"> <li>• Reports Log (N/A)</li> <li>• CM reminded Korando that they need to routinely submit the following starting at the date of the NTP:               <ul style="list-style-type: none"> <li>○ Certified Payrolls (including subs)</li> <li>○ Apprentice Training Reports</li> <li>○ Traffic Control Reports</li> <li>○ Contractor Daily Reports</li> <li>○ Turtle Surveys (and other wildlife surveys/reports as required)</li> <li>○ Water Quality Monitoring Reports</li> </ul> </li> </ul>	Korando
<p><b>7 SAFETY/TRAFFIC CONTROL</b></p> <ul style="list-style-type: none"> <li>• Site Safety – not discussed.</li>   <li>• Traffic Control – DPW should review the MOT plan.</li> </ul>	
<p><b>8 QUALITY CONTROL</b></p> <ul style="list-style-type: none"> <li>• Not discussed.</li> </ul>	



	<u>ACTION REQUIRED</u>
<p><b>9 ENVIRONMENTAL</b></p> <ul style="list-style-type: none"><li>• Korando needs to coordinate a site visit by Guam EPA and DOA prior to performing any clearing or other disturbance of the site.</li><li>• Korando will need to provide a water truck for dust control during construction.</li><li>• Erosion Control requirements also apply to the Contractor's yard.</li></ul>	Korando
<p><b>10 OPEN ISSUES</b></p> <ul style="list-style-type: none"><li>• None</li></ul>	
<p><b>11 NEW ISSUES</b></p> <ul style="list-style-type: none"><li>• None</li></ul>	



properties (see 36 CFR 800.3(a)). If NHPA section 106 consultation is required and will occur, the district engineer will notify the non-Federal applicant that he or she cannot begin work until Section 106 consultation is completed. If the non-Federal applicant has not heard back from the Corps within 45 days, the applicant must still wait for notification from the Corps.

(e) Prospective permittees should be aware that section 110k of the NHPA (16 U.S.C. 470h-2(k)) prevents the Corps from granting a permit or other assistance to an applicant who, with intent to avoid the requirements of Section 106 of the NHPA, has intentionally significantly adversely affected a historic property to which the permit would relate, or having legal power to prevent it, allowed such significant adverse effect to occur, unless the Corps, after consultation with the Advisory Council on Historic Preservation (ACHP), determines that circumstances justify granting such assistance despite the adverse effect created or permitted by the applicant. If circumstances justify granting the assistance, the Corps is required to notify the ACHP and provide documentation specifying the circumstances, the degree of damage to the integrity of any historic properties affected, and proposed mitigation. This documentation must include any views obtained from the applicant, SHPO/THPO, appropriate Indian tribes if the undertaking occurs on or affects historic properties on tribal lands or affects properties of interest to those tribes, and other parties known to have a legitimate interest in the impacts to the permitted activity on historic properties.

#### **21. Discovery of Previously Unknown Remains and Artifacts.**

If you discover any previously unknown historic, cultural or archeological remains and artifacts while accomplishing the activity authorized by this permit, you must immediately notify the district engineer of what you have found, and to the maximum extent practicable, avoid construction activities that may affect the remains and artifacts until the required coordination has been completed. The district engineer will initiate the Federal, Tribal and state coordination required to determine if the items or remains warrant a recovery effort or if the site is eligible for listing in the National Register of Historic Places.

#### **22. Designated Critical Resource Waters.**

Critical resource waters include, NOAA-managed marine sanctuaries and marine monuments, and National Estuarine Research Reserves. The district engineer may designate, after notice and opportunity for public comment, additional waters officially designated by a state as having particular environmental or ecological significance, such as outstanding national resource waters or state natural heritage sites. The district engineer may also designate additional critical resource waters after notice and opportunity for public comment.

(a) Discharges of dredged or fill material into waters of the United States are not authorized by NWP's 7, 12, 14, 16, 17, 21, 29, 31, 35, 39, 40, 42, 43, 44, 49, 50, 51, and 52 for any activity within, or directly affecting, critical resource waters, including wetlands adjacent to such waters.

(b) For NWP's 3, 8, 10, 13, 15, 18, 19, 22, 23, 25, 27, 28, 30, 33, 34, 36, 37, and 38, notification is required in accordance with general condition 31, for any activity proposed in the designated critical resource waters including wetlands adjacent to those waters. The district engineer may authorize activities under these NWP's only after it is determined that the impacts to the critical resource waters will be no more than minimal.

#### **23. Mitigation.**

The district engineer will consider the following factors when determining appropriate and practicable mitigation necessary to ensure that adverse effects on the aquatic environment are minimal:

(a) The activity must be designed and constructed to avoid and minimize adverse effects, both temporary and permanent, to waters of the United States to the maximum extent practicable at the project site (i.e., on site).

(b) Mitigation in all its forms (avoiding, minimizing, rectifying, reducing, or compensating for resource losses) will be required to the extent necessary to ensure that the adverse effects to the aquatic environment are minimal.

(c) Compensatory mitigation at a minimum one-for-one ratio will be required for all wetland losses that exceed 1/10-acre and require preconstruction notification, unless the district engineer determines in writing that either some other form of mitigation would be more environmentally appropriate or the adverse effects of the proposed activity are minimal, and provides a project-specific waiver of this requirement. For wetland losses of 1/10-acre or less that require pre-construction notification, the district engineer may determine on a case-by-case basis that compensatory mitigation is required to ensure that the activity results in minimal adverse effects on the aquatic environment. Compensatory mitigation projects provided to offset losses of aquatic resources must comply with the applicable provisions of 33 CFR part 332.



(1) The prospective permittee is responsible for proposing an appropriate compensatory mitigation option if compensatory mitigation is necessary to ensure that the activity results in minimal adverse effects on the aquatic environment.

(2) Since the likelihood of success is greater and the impacts to potentially valuable uplands are reduced, wetland restoration should be the first compensatory mitigation option considered.

(3) If permittee-responsible mitigation is the proposed option, the prospective permittee is responsible for submitting a mitigation plan. A conceptual or detailed mitigation plan may be used by the district engineer to make the decision on the NWP verification request, but a final mitigation plan that addresses the applicable requirements of 33 CFR 332.4(c)(2)-(14) must be approved by the district engineer before the permittee begins work in waters of the United States, unless the district engineer determines that prior approval of the final mitigation plan is not practicable or not necessary to ensure timely completion of the required compensatory mitigation (see 33 CFR 332.3(k)(3)).

(4) If mitigation bank or in-lieu fee program credits are the proposed option, the mitigation plan only needs to address the baseline conditions at the impact site and the number of credits to be provided.

(5) Compensatory mitigation requirements (e.g., resource type and amount to be provided as compensatory mitigation, site protection, and ecological performance standards, monitoring requirements) may be addressed through conditions added to the NWP authorization, instead of components of a compensatory mitigation plan.

(d) For losses of streams or other open waters that require pre-construction notification, the district engineer may require compensatory mitigation, such as stream rehabilitation, enhancement, or preservation, to ensure that the activity results in minimal adverse effects on the aquatic environment.

(e) Compensatory mitigation will not be used to increase the acreage losses allowed by the acreage limits of the NWPs. For example, if an NWP has an acreage limit of 1/2-acre, it cannot be used to authorize any project resulting in the loss of greater than 1/2-acre of waters of the United States, even if compensatory mitigation is provided that replaces or restores some of the lost waters. However, compensatory mitigation can and should be used, as necessary, to ensure that a project already meeting the established acreage limits also satisfies the minimal impact requirement associated with the NWPs.

(f) Compensatory mitigation plans for projects in or near streams or other open waters will normally include a requirement for the restoration or establishment, maintenance, and legal protection (e.g., conservation easements) of riparian areas next to open waters. In some cases, riparian areas may be the only compensatory mitigation required. Riparian areas should consist of native species. The width of the required riparian area will address documented water quality or aquatic habitat loss concerns. Normally, the riparian area will be 25 to 50 feet wide on each side of the stream, but the district engineer may require slightly wider riparian areas to address documented water quality or habitat loss concerns. If it is not possible to establish a riparian area on both sides of a stream, or if the waterbody is a lake or coastal waters, then restoring or establishing a riparian area along a single bank or shoreline may be sufficient. Where both wetlands and open waters exist on the project site, the district engineer will determine the appropriate compensatory mitigation (e.g., riparian areas and/or wetlands compensation) based on what is best for the aquatic environment on a watershed basis. In cases where riparian areas are determined to be the most appropriate form of compensatory mitigation, the district engineer may waive or reduce the requirement to provide wetland compensatory mitigation for wetland losses.

(g) Permittees may propose the use of mitigation banks, in-lieu fee programs, or separate permittee-responsible mitigation. For activities resulting in the loss of marine or estuarine resources, permittee-responsible compensatory mitigation may be environmentally preferable if there are no mitigation banks or in-lieu fee programs in the area that have marine or estuarine credits available for sale or transfer to the permittee. For permittee-responsible mitigation, the special conditions of the NWP verification must clearly indicate the party or parties responsible for the implementation and performance of the compensatory mitigation project, and, if required, its long-term management.

(h) Where certain functions and services of waters of the United States are permanently adversely affected, such as the conversion of a forested or scrub-shrub wetland to an herbaceous wetland in a permanently maintained utility line right-of-way, mitigation may be required to reduce the adverse effects of the project to the minimal level.

#### **24. Safety of Impoundment Structures.**

To ensure that all impoundment structures are safely designed, the district engineer may require non-Federal applicants to demonstrate that the structures comply with established state dam safety criteria or have been designed by qualified persons. The district engineer may also require documentation that the design has been independently reviewed by similarly qualified persons, and appropriate modifications made to ensure safety.



**Transmittal/Review/Approval**

FILE NAME: Bile and Pigua Recovery NAS

DATE: 4/16/2015

CONTRACT NO.: GU-NH-NBIS(007)	TITLE: (Fill in Project Title/Location Here) Bile / Pigua Bridge Replacement (Construction Phase), Route 4, Merizo, Guam
FROM (CONTRACTOR): Korando Corporation	TO: Jack Marlowe / Chief Project Rep.      SUBMITTAL NO.: 155.005-01      SPECS. SECTION: 155

ENCL. NO.	NO. OF COPIES	DESCRIPTION	SPEC.SEC./PARA	SCHEDULE ACTIVITY NO.	CQC CODE
		Bile & Pigua Bridge Replacement (Construction Phase)			
1	2	Recovery Narrative	155.02 to 04	A1010	A
2	8	Bile and Pigua Recovery NAS / Progress Ending 3.31.2015			
3	10	Report Showing Status and Critical activities			

DATE NEEDED BY:

TRANSMITTED FOR:     APPROVAL     CLARIFICATION     SELECTION     RECORD     VARIANCE

*It is hereby certified that the material submitted herein conforms to contract requirements and can be installed in the allocated spaces.*

CONTRACTOR'S REPRESENTATIVE NAME/TITLE Ruel Remetira / Korando	SIGNATURE:
---	------------

Received By (Print Name & Sign)/Date/Time: Jack Marlowe / Stanley 1/26/2015

FROM:	SIGNATURE:	DATE:
-------	------------	-------

TO: Jack Marlowe / Stanley Consultants	<i>For review/comment ( ) copies of enclosures forwarded. RETURN WITHIN ( ) WORKING DAYS, unless submittal is for record/info purposes only and there are no adverse comments.</i>
---	--

Received By (Print Name & Sign)/Date/Time: Jack Marlowe / Stanley 1/26/2015

FROM:	TO:	DATE:
-------	-----	-------

RECOMMEND / Enclosure(s) is (are):

<input type="checkbox"/> No Exception Taken (NET)	<input type="checkbox"/> Rejected/Resubmit (Rej/R)	<input type="checkbox"/> _____
<input type="checkbox"/> Exceptions As Noted (EAN)	<input type="checkbox"/> No Action Required (NAR)	<input type="checkbox"/> _____
<input type="checkbox"/> Revise/Resubmit (Rev/R)	<input type="checkbox"/> Not Subject To Review (NSTR)	

REMARKS:

Copies of encls returned:      SIGNATURE: \_\_\_\_\_

Copy to: \_\_\_\_\_

Received By (Print Name & Sign)/Date/Time: \_\_\_\_\_



**KORANDO CORPORATION**  
**GENERAL CONTRACTOR**

P.O. BOX 20638  
GMF, GUAM 96921  
TEL: (671) 649-7880  
(671) 649-7881  
FAX: (671) 649-7882  
EMAIL: admin\_korando@teleguam.net

## Bile and Pigua Recovery & Progress Schedule March 31, 2015

### Narrative

Recovery Network Analysis Schedule (NAS) was revised due to the following realistic reasons:

1. Unexpected archaeological work schedule issues. It was found out that the staging area were not inclusive in the works stipulated in the contracts. The work limit in the bridge project area is very narrow to receive some of the construction materials that push contractor to look for a private property nearby to use as a staging area. The bid books stated that the contractor shall be responsible for obtaining the appropriate permits and clearances for the use of staging areas located outside the Area of Potential Effect (APE) (limits of construction) established for this project. Korando did not anticipate that the archaeological works will takes longer time in which the activities to include the draft reports, review, foot survey, manual boring, final reports, review and approved by SHPO. Thus, anticipated days of work will be 90 days. Note that this archaeological requirements is driving the precast/prestressed box beam fabrication activities. Once the SHPO reports/recommendation is received the construction of the temporary fabrication structure begin.
2. It is anticipated also that the narrow work space will hinder the work phasing plan to become unrealistic during actual implementation and maybe revised to consider the actual conditions/situations that may encounter during work progress. The limited work space in the right-of-way will limit the movements of equipment and the public vehicles during construction period. The residence driveway will also be affected.
3. Precast/prestressed pile fabrication drawing, and design was revised to original octagonal shape, no problem with the fabrication works on the octagonal shape as per Rocky Mountain Precast. Once materials arrived from off-island fabrication of test piles will start right away at RMP yard (May 12, 2015). Test piles fabrication will tentatively completed and delivered at Merizo site on Jun 10, 2015, test pile driving will then starts. Fabrication of the rest of the octagonal piles will then be starts once required length is determined.
4. Other major activities that can affect most of the predecessors is the temporary steel bridge. Temporary steel bridge is required in the seaside due (1) to the road centerline is located in the existing temporary bridge at mountain side that cause narrow working space at the seaside; and (2) the existing bridge was only supported by 6 inch depth steel beam which structural integrity is weak to

received heavy crane load/vibration that will passing through the bridge from Bile to Pigua area and vise versa. Steel bridge design is still on-going and hopefully by the Month of May 2015, the fabrication shall starts 30 days for each bridge.

5. Pile driving activities at mountain side is driven by the relocation of overhead power lines. The pile location is directly underneath of the high voltage primary power lines above that cause that this relocation activities shall be done first before pile driving begins.





Activity ID	Activity Name	%	Orig Dur	Rem Dur	Start	Finish	Total Float	2015												2016							
								Jan	Feb	Mar	Apr	May	Jun	Jul	Aug	Sep	Oct	Nov	Dec	Jan	Feb	Mar	Apr				
<b>Bile / Pigua Bridge Replacement (Construction Phase)</b>								449d	364d	05-Jan-15 A	29-Mar-16	0d															
<b>GENERAL REQUIREMENTS</b>								175d	36d	05-Jan-15 A	05-May-15	0d															
A1000	Notice to Proceed / Start Administrative Submittals	100%	0d	0d	05-Jan-15 A			◆ Notice to Proceed / Start Administrative Submittals																			
A1010	Submit Network Analysis (NAS) Project Schedule	100%	20d	0d	05-Jan-15 A	24-Jan-15 A		■ Submit Network Analysis (NAS) Project Schedule																			
A1020	Submit Schedule of Values	100%	20d	0d	05-Jan-15 A	24-Jan-15 A		■ Submit Schedule of Values																			
A1030	Submit Submittal Register	100%	20d	0d	05-Jan-15 A	24-Jan-15 A		■ Submit Submittal Register																			
A1040	Submit Quality Control Plan (QC Plan)	100%	30d	0d	05-Jan-15 A	23-Jan-15 A		■ Submit Quality Control Plan (QC Plan)																			
A1050	Submit Environmental Protection Plan (EPP), & ECP	100%	30d	0d	05-Jan-15 A	26-Feb-15 A		■ Submit Environmental Protection Plan (EPP), & ECP																			
A1060	Submit Accident Prevention Plan (APP)	100%	30d	0d	05-Jan-15 A	26-Feb-15 A		■ Submit Accident Prevention Plan (APP)																			
A1070	Submit Stormwater Pollution Prevention Plan (SWPPP)	100%	30d	0d	05-Jan-15 A	02-Feb-15 A		■ Submit Stormwater Pollution Prevention Plan (SWPPP)																			
A1080	Submit Traffic Control Plan for Phase 1, 2, 3, and 4	100%	30d	0d	05-Jan-15 A	13-Jan-15 A		■ Submit Traffic Control Plan for Phase 1, 2, 3, and 4																			
A1090	Highway Encroachment Permitting	100%	30d	0d	05-Jan-15 A	08-Jan-15 A		■ Highway Encroachment Permitting																			
A1100	GEPA Permitting and 401 Certs (Water Quality Monitoring Plan)	100%	30d	0d	05-Jan-15 A	26-Feb-15 A		■ GEPA Permitting and 401 Certs (Water Quality Monitoring Plan)																			
A1110	Department of Agriculture Orientation & Monitoring	100%	30d	0d	05-Jan-15 A	30-Mar-15 A		■ Department of Agriculture Orientation & Monitoring																			
A112	Archaeological Survey Requirements for Staging Area	60%	90d	36d	20-Jan-15 A	05-May-15	0d	■ Archaeological Survey Requirements for Staging Area																			
<b>DESIGN, DRAWINGS, &amp; PROCUREMENT STAGE</b>								211d	126d	05-Jan-15 A	04-Aug-15	72d															
A1120	Determine, Verify, and Marking Location of Existing Utilities	100%	5d	0d	05-Jan-15 A	09-Jan-15 A		■ Determine, Verify, and Marking Location of Existing Utilities																			
A1130	Design & Approval of Temporary Access Structures	50%	30d	15d	12-Jan-15 A	14-Apr-15	16d	■ Design & Approval of Temporary Access Structures																			
A1140	Prepare Material Submittals, Review, & Approval	40%	22d	13d	12-Jan-15 A	13-Apr-15	0d	■ Prepare Material Submittals, Review, & Approval																			
A1150	Prepare Shopdrawing for Final Structure Dimensions & Rebar Schedule	15%	30d	26d	10-Jan-15 A	25-Apr-15	10d	■ Prepare Shopdrawing for Final Structure Dimensions & Rebar Schedule																			
A1152	Procure and Delivery Construction Materials	40%	60d	36d	19-Jan-15 A	31-May-15	10d	■ Procure and Delivery Construction Materials																			
A1160	Prepare Shopdrawing for Utilities Lines Exact Locations	0%	30d	30d	31-Mar-15	29-Apr-15	27d	■ Prepare Shopdrawing for Utilities Lines Exact Locations																			
A1162	Prepare PC Pile Material Submittals, Review, & Approval	30%	60d	42d	09-Feb-15 A	11-May-15	0d	■ Prepare PC Pile Material Submittals, Review, & Approval																			
A1164	Shop Fab. & Del. for Test Piles (4 for Bile & 8 for Pigua) Early Strength	0%	30d	30d	12-May-15	10-Jun-15	0d	■ Shop Fab. & Del. for Test Piles (4 for Bile & 8 for Pigua) Early Strength																			
A1170	Fab. & Del. of Remaining Prestressed Concrete Piles (Bile Area)	0%	23d	23d	19-Jun-15	12-Jul-15	0d	■ Fab. & Del. of Remaining Prestressed Concrete Piles (Bile Area)																			
A1172	Fab. & Del. of Remaining Prestressed Concrete Piles (Pigua Area)	0%	21d	21d	14-Jul-15	04-Aug-15	0d	■ Fab. & Del. of Remaining Prestressed Concrete Piles (Pigua Area)																			
A1200	Procure and Delivery Electrical Materials & Associated Accessories	10%	60d	54d	30-Mar-15 A	23-May-15	27d	■ Procure and Delivery Electrical Materials & Associated Accessories																			
A1210	Procure and Delivery Waterline and Accessories	0%	60d	60d	31-Mar-15	29-May-15	138d	■ Procure and Delivery Waterline and Accessories																			
<b>CONSTRUCTION PHASE</b>								341d	341d	19-Mar-15 A	19-Mar-16	0d															
A1220	Start Construction	100%	0d	0d	19-Mar-15 A			■ Start Construction																			
A1230	Construction Survey, Staking, and Layout	100%	12d	0d	19-Mar-15 A	31-Mar-15 A		■ Construction Survey, Staking, and Layout																			
A1240	Mobilize Manpower and Equipment (Initial)	50%	30d	15d	27-Mar-15 A	28-Apr-15	15d	■ Mobilize Manpower and Equipment (Initial)																			
A1250	Implement Traffic Control / Warning for All Areas	60%	15d	6d	30-Mar-15 A	19-Apr-15	15d	■ Implement Traffic Control / Warning for All Areas																			
A1252	Clearing and Grubbing (Staging Area)	60%	12d	5d	19-Mar-15 A	10-May-15	15d	■ Clearing and Grubbing (Staging Area)																			
A1255	Clearing and Grubbing (Bile and Pigua Area)	0%	12d	12d	19-Apr-15	01-May-15	15d	■ Clearing and Grubbing (Bile and Pigua Area)																			
A1260	Construct Temporary Facilities and Chainlink Fencing	0%	10d	10d	01-May-15	11-May-15	15d	■ Construct Temporary Facilities and Chainlink Fencing																			
A1265	Excavation for Archaeological Survey/Testing and Submit Final Report	0%	10d	10d	06-May-15	15-May-15	0d	■ Excavation for Archaeological Survey/Testing and Submit Final Report																			
A1270	Established & Install Erosion Control / Protection	0%	10d	10d	1-May-15	25-May-15	0d	■ Established & Install Erosion Control / Protection																			

Remaining Level of Effort    
  Critical Remaining Work    
  Primary Baseline  
 Actual Work    
 ◆ Milestones  
 Remaining Work    
 ▼ Summary

**BILE/PIGUA BRIDGE REPLACEMENT (CONSTRUCTION PHASE)  
 PROJECT RECOVERY SCHEDULE (REV. 03.31.2015)**

Date	Revision	Checked	Approved



Project Name: Bile / Pigua Bridge Replacement (Construction Phase)  
 Contract No.: CU-NI-NBIS(007)

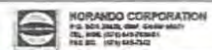

Date Date: 31-Mar-15  
 Run Date: 16-Apr-15

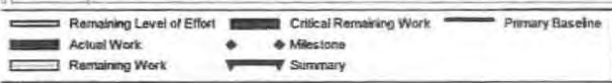
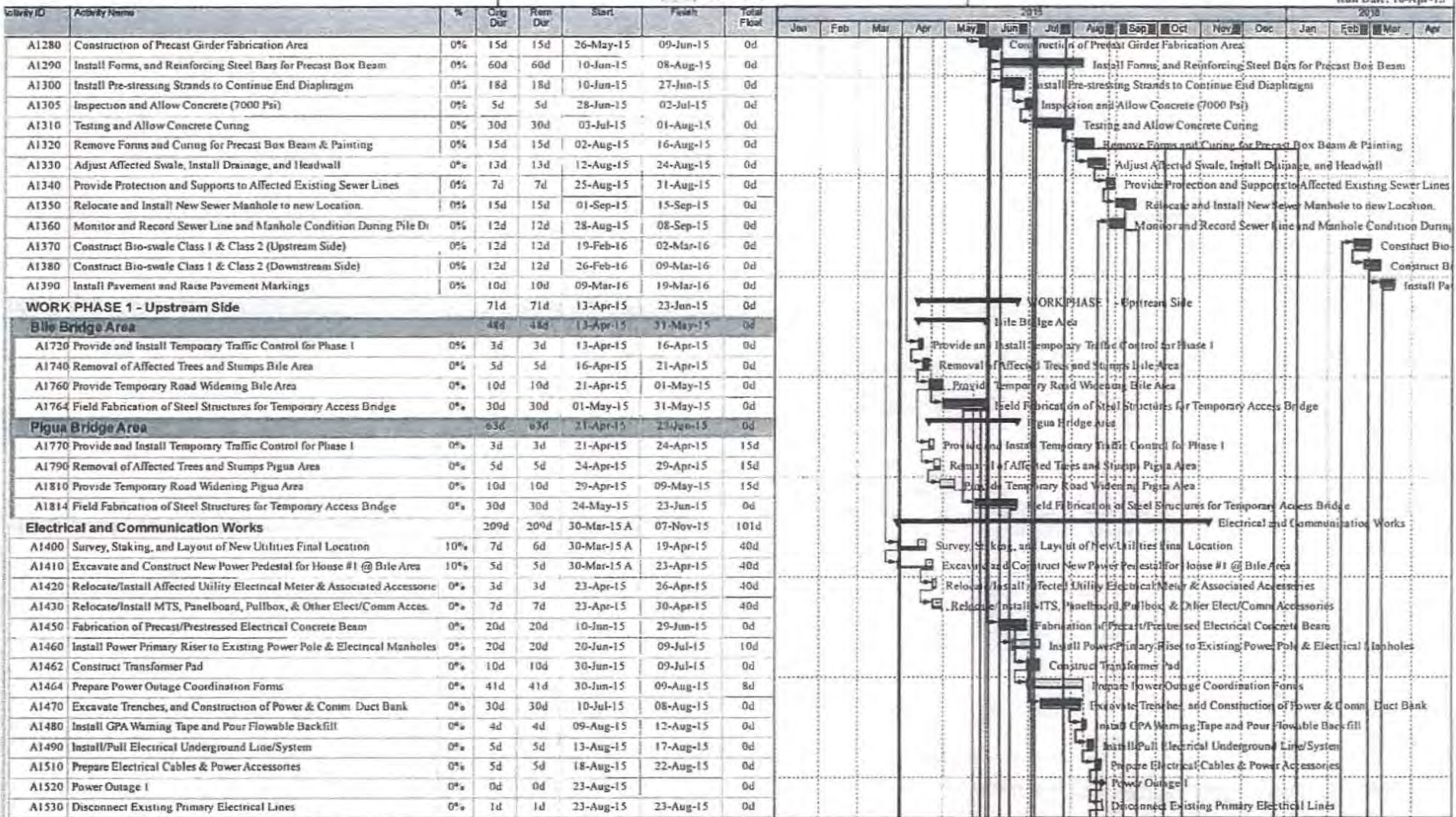

BILE/PIGUA BRIDGE REPLACEMENT (CONSTRUCTION PHASE)  
 PROJECT RECOVERY SCHEDULE (REV. 03.31.2015)

Date	Revision	Checked	Approved



Project Name: Bile / Pigua Bridge Replacement (Construction Phase)  
 Contract No.: CU-NH-NBIS(007)



Date Date: 31-Mar-15

Run Date: 16-Apr-15

Activity ID	Activity Name	%	Orig Dur	Rem Dur	Start	Finish	Total Float	2015																
								Jan	Feb	Mar	Apr	May	Jun	Jul	Aug	Sep	Oct	Nov	Dec					
A1540	Install/Relocate Secondary Conductors	0%	1d	1d	23-Aug-15	23-Aug-15	0d																	
A1542	Transfer of Transformer and Accessories	0%	1d	1d	23-Aug-15	23-Aug-15	0d																	
A1550	Connect Existing Primary Lines to New Power Lines	0%	1d	1d	23-Aug-15	23-Aug-15	0d																	
A1560	Relocate Overhead Streetlight	0%	1d	1d	23-Aug-15	23-Aug-15	0d																	
A1570	Modify Crossarm at Old Power Poles	0%	1d	1d	23-Aug-15	23-Aug-15	0d																	
A1580	Intercept Underground Service for Existing Sewer Pump Station	0%	1d	1d	24-Aug-15	24-Aug-15	0d																	
A1590	Connect Power Lines to House #1	0%	1d	1d	24-Aug-15	24-Aug-15	0d																	
A1600	Conduct Megger Testing	0%	1d	1d	25-Aug-15	25-Aug-15	0d																	
A1610	Energyization Schedule	0%	0d	0d		25-Aug-15	0d																	
A1620	Remove Old Pole and Accessories	0%	10d	10d	26-Aug-15	04-Sep-15	101d																	
A1630	Demolition of Old Power Pedestal & Disposal	0%	6d	6d	05-Sep-15	10-Sep-15	101d																	
A1640	Excavate and Install Handhole and Comm Shutter Box	0%	15d	15d	11-Sep-15	25-Sep-15	101d																	
A1650	Relocate of Communication Cables & Accessories (By Docomo)	0%	10d	10d	26-Sep-15	05-Oct-15	101d																	
A1660	Relocate of Communication Cables & Accessories (By GTA)	0%	10d	10d	06-Oct-15	15-Oct-15	101d																	
A1670	Underground Comm. Cable Pulling and Splicing Works	0%	7d	7d	16-Oct-15	22-Oct-15	101d																	
A1680	Disconnect Existing Communication Cables	0%	3d	3d	23-Oct-15	25-Oct-15	101d																	
A1690	Reconnect Communications Cables to New Lines	0%	3d	3d	26-Oct-15	28-Oct-15	101d																	
A1700	Pull-out/Remove Old Existing Cable, Conduit, and Secure	0%	6d	6d	29-Oct-15	03-Nov-15	101d																	
A1710	Testing and Commissioning of Electrical Equipment	0%	4d	4d	04-Nov-15	07-Nov-15	101d																	
<b>WORK PHASE 2 - Downstream Side</b>								<b>WORK PHASE 2 - Downstream Side</b>																
<b>Bile Bridge Area</b>			61d	61d	31-May-15	31-Jul-15	24d	<b>Bile Bridge Area</b>																
A1820	Provide and Install Temporary Traffic Control for Phase 2	0%	5d	5d	31-May-15	05-Jun-15	5d																	
A1850	Mobilize Crane & Pile Driving Hammer to Bile Area Downstream Side	0%	2d	2d	05-Jun-15	07-Jun-15	0d																	
A1860	Saw Cutting and Removal of Asphalt Pavement	0%	2d	2d	07-Jun-15	09-Jun-15	0d																	
A1870	Excavation/Preparation for Pile Driving	0%	2d	2d	09-Jun-15	11-Jun-15	0d																	
A1880	PC Pile Driving and Conduct Dynamic Pile Load Test	0%	8d	8d	11-Jun-15	19-Jun-15	0d																	
A1890	Continue PC Pile Driving up to the Designed Depth (30')	0%	16d	16d	12-Jul-15	28-Jul-15	0d																	
A1900	Provide and Drive Steel Sheet Piles / Temporary Earth Shoring	0%	3d	3d	28-Jul-15	31-Jul-15	24d																	
A2000	Chip Pile Head to Road Level, Backfill, and Compaction	0%	3d	3d	28-Jul-15	31-Jul-15	0d																	
<b>Pigua Bridge Area</b>			74d	78d	09-Jun-15	26-Aug-15	0d	<b>Pigua Bridge Area</b>																
A2010	Provide and Install Temporary Traffic Control for Phase 2	0%	5d	5d	09-Jun-15	14-Jun-15	12d																	
A2040	Mobilize Crane & Pile Driving Hammer to Pigua Area Downstream Side	0%	2d	2d	26-Jun-15	28-Jun-15	0d																	
A2050	Saw Cutting and Removal of Asphalt Pavement	0%	2d	2d	28-Jun-15	30-Jun-15	0d																	
A2060	Excavation/Preparation for Pile Driving	0%	2d	2d	30-Jun-15	02-Jul-15	0d																	
A2070	PC Pile Driving and Conduct Dynamic Pile Load Test	0%	12d	12d	02-Jul-15	14-Jul-15	0d																	
A2080	Continue PC Pile Driving up to the Designed Depth (100')	0%	18d	18d	04-Aug-15	22-Aug-15	0d																	
A2090	Provide and Drive Steel Sheet Piles / Temporary Earth Shoring	0%	2d	2d	22-Aug-15	24-Aug-15	2d																	
A2100	Chip Pile Head to Road Level, Backfill, and Compaction	0%	2d	2d	24-Aug-15	26-Aug-15	0d																	
<b>WORK PHASE 3 - Upstream Side</b>								<b>WORK PHASE 3 - Upstream Side</b>																

Remaining Level of Effort    
  Critical Remaining Work    
  Primary Baseline  
 Actual Work    
 ◆ Milestone  
 Remaining Work    
 ▼ Summary

**BILE/PIGUA BRIDGE REPLACEMENT (CONSTRUCTION PHASE)  
 PROJECT RECOVERY SCHEDULE (REV. 03.31.2015)**

Date	Revision	Checked	Approved







Project Name: Bile / Pigua Bridge Replacement (Construction Phase)  
 Contract No.: GU-NII-NBIS(007)



Date Date: 31-Mar-15

Run Date: 16-Apr-15

Activity ID	Activity Name	%	Orig Dur	Rem Dur	Start	Finish	Total Float	2015												2016						
								Jan	Feb	Mar	Apr	May	Jun	Jul	Aug	Sep	Oct	Nov	Dec	Jan	Feb	Mar	Apr			
<b>Pigua Bridge Area</b>																										
A2500	Relocate and Install Temporary Traffic Controls for Phase 3	0%	3d	3d	01-Sep-15	04-Sep-15	8d																			
A2510	Mobilize Crane & Pile Driving Hammer to Pigua Area Upstream Side	0%	2d	2d	09-Sep-15	11-Sep-15	0d																			
A2520	Saw Cutting and Removal of Asphalt Pavement	0%	3d	3d	11-Sep-15	14-Sep-15	0d																			
A2530	Excavation/Preparation for Driving Pile	0%	2d	2d	12-Sep-15	14-Sep-15	0d																			
A2550	Continue PC Pile Driving up to the Designed Depth (100')	0%	16d	16d	14-Sep-15	30-Sep-15	0d																			
A2560	Excavation for Pile Cap Projection to Designed Elevations	0%	3d	3d	30-Sep-15	03-Oct-15	0d																			
A2570	Chop Pile Head to Expose Reinforcement as Dowel Bars	0%	4d	4d	01-Oct-15	05-Oct-15	0d																			
A2580	Backfilling, Trimming and Compaction for Pile Cap Base	0%	4d	4d	03-Oct-15	07-Oct-15	0d																			
A2590	Backfill with Base Course & Compaction for Pile Cap Base	0%	3d	3d	05-Oct-15	08-Oct-15	0d																			
A2600	Lean Concrete Pouring at Pile Cap Base	0%	1d	1d	08-Oct-15	09-Oct-15	0d																			
A2610	Installation of Fabricated Reinforcing Steel Bars for Pile Caps	0%	10d	10d	09-Oct-15	19-Oct-15	0d																			
A2620	Installation of Forms and Supports for Pile Caps	0%	10d	10d	14-Oct-15	24-Oct-15	0d																			
A2630	Inspection and Corrections	0%	2d	2d	23-Oct-15	25-Oct-15	0d																			
A2640	Concrete Pouring for Pile Caps and Take Concrete Samples	0%	2d	2d	25-Oct-15	27-Oct-15	0d																			
A2650	Removal of Pile Cap Forms & Curing Application	0%	4d	4d	27-Oct-15	31-Oct-15	0d																			
A2660	Demolish Temp. Access and Portion of Existing Bridge & Dispose Offsite	0%	7d	7d	27-Oct-15	03-Nov-15	0d																			
A2670	Excavation, Benching, and Trimming Portion of Soil for Riprap Location	0%	6d	6d	27-Oct-15	02-Nov-15	0d																			
A2680	Construct Portion of Grouted Riprap Slope Protection	0%	6d	6d	30-Oct-15	05-Nov-15	0d																			
A2690	Erection of Fabricated Bridge Box Girders into Place	0%	14d	14d	28-Oct-15	11-Nov-15	0d																			
A2700	Install 7/8" Dia. Transverse Tie Rod Anchorage at Beam Mid Diaphragm	0%	6d	6d	07-Nov-15	13-Nov-15	0d																			
A2710	Grout Application at Beam Mid Diaphragm where required	0%	4d	4d	13-Nov-15	17-Nov-15	0d																			
A2720	Forms, Reinforcements, and Concrete Pouring for CIP End Diaphragm	0%	6d	6d	13-Nov-15	19-Nov-15	0d																			
A2730	Forms, Rebar, and Concrete End Box Beam Bridge Barrier	0%	8d	8d	15-Nov-15	23-Nov-15	0d																			
A2740	Install 6" Dia. PVC Perforated Drain Pipe	0%	1d	1d	15-Nov-15	16-Nov-15	0d																			
A2750	Install 5/8" Thick Geocomposite Drain Board	0%	2d	2d	15-Nov-15	17-Nov-15	0d																			
A2760	Backfilling and Compaction Pile Cap Area	0%	4d	4d	15-Nov-15	19-Nov-15	0d																			
A2770	Excavation, Trimming, and Leveling Portion of Concrete Abutment	0%	6d	6d	15-Nov-15	21-Nov-15	0d																			
A2780	Lay Basecourse, Leveling, and Compaction for Portion of Concrete Abu	0%	4d	4d	19-Nov-15	23-Nov-15	0d																			
A2790	Install Forms, and Reinforcing Steel Bars for Portion of Concrete Abutme	0%	6d	6d	23-Nov-15	29-Nov-15	0d																			
A2800	Concrete Pouring for Portion of Concrete Abutment	0%	1d	1d	29-Nov-15	30-Nov-15	0d																			
A2810	Forms, Rebars, and Pour Concrete for Wing Wall	0%	4d	4d	30-Nov-15	04-Dec-15	0d																			
A2820	Roughen and Water Blast Top Surface of Box Beam in Transverse Direct	0%	2d	2d	30-Nov-15	02-Dec-15	0d																			
A2830	Aggregate Base, Grading C, 8-Inch Depth	0%	4d	4d	30-Nov-15	04-Dec-15	0d																			
A2840	Tack Coat and Hot Mix Asphalt (HMA) Concrete Pavement Application	0%	3d	3d	04-Dec-15	07-Dec-15	0d																			
A2850	Hot Mix Asphalt (HMA) Concrete Pavement, Friction Course, 1-inch De	0%	2d	2d	06-Dec-15	08-Dec-15	0d																			
A2860	Install Guardrail Anchorage Trailing End	0%	5d	5d	07-Dec-15	12-Dec-15	0d																			
A2870	Install Guardrail (Type W & Type T)	0%	4d	4d	10-Dec-15	14-Dec-15	0d																			
<b>WORK PHASE 4 - Downstream Side</b>			116d	116d	24-Nov-15	19-Mar-16	0d																			

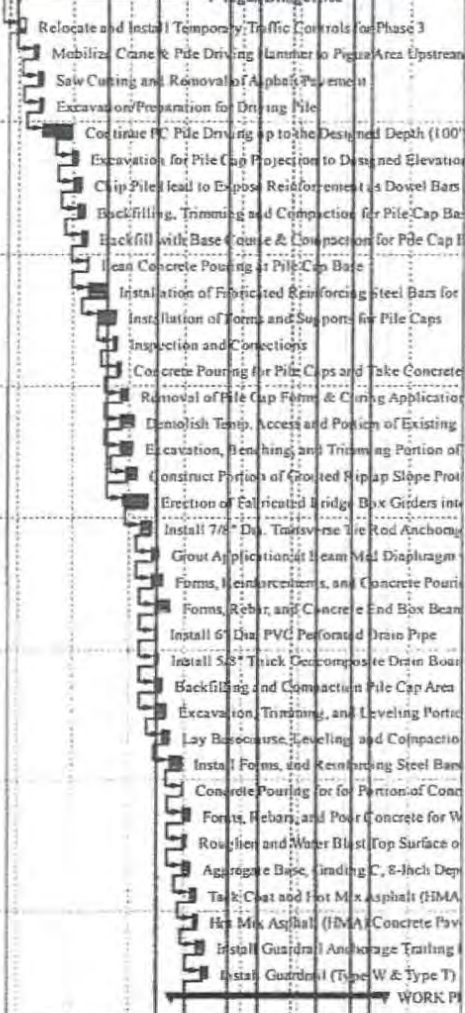

Remaining Level of Effort	Critical Remaining Work	Primary Baseline
Actual Work	Milestone	
Remaining Work	Summary	

BILE/PIGUA BRIDGE REPLACEMENT (CONSTRUCTION PHASE)  
 PROJECT RECOVERY SCHEDULE (REV. 03.31, 2015)

Date	Revision	Checked	Approved













### Schedule Reports Showing Activity Status & Critical

**Critical**

Activity ID	Activity Name	Activity Status	Critical	Successors	Predecessors
<b>No</b>					
A1000	Notice to Proceed / Start Administrative Submittals	Completed	No		A1120, A1220, A1090, A1050, A1020, A1070, A1030, A1060, A1040, A1110, A1100, A1010, A1080, A1112
A1010	Submit Network Analys (NAS) Project Schedule	Completed	No	A1000	A1220
A1020	Submit Schedule of Values	Completed	No	A1000	A1220
A1030	Submit Submittal Register	Completed	No	A1000	A1220
A1040	Submit Quality Control Plan (QC Plan)	Completed	No	A1000	A1220
A1050	Submit Environmental Protection Plan (EPP), & ECP	Completed	No	A1000	A1220
A1060	Submit Accident Prevention Plan (APP)	Completed	No	A1000	A1220
A1070	Submit Stormwater Pollution Prevention Plan (SWPPP)	Completed	No	A1000	A1220
A1080	Submit Traffic Control Plan for Phase 1, 2, 3, and 4	Completed	No	A1000	A1255
A1090	Highway Encroachment Permitting	Completed	No	A1000	A1220
A1100	GEPA Permitting and 401 Certs (Water Quality Monitoring Plan)	Completed	No	A1000	A1220
A1110	Department of Agriculture Orientation & Monitoring	Completed	No	A1000	A1220
A1120	Determine, Verify, and Marking Location of Existing Utilities	Completed	No	A1000	A1130, A1140, A1150, A1160, A1162
A1130	Design & Approval of Temporary Access Structures	In Progress	No	A1120	A1764
A1150	Prepare Shopdrawing for Final Structure Dimensions & Rebar Schedule	In Progress	No	A1120	A1152
A1152	Procure and Delivery Construction Materials	In Progress	No	A1150	A1290, A1300
A1160	Prepare Shopdrawing for Utilities Lines Exact Locations	Not Started	No	A1120	A1200, A1210
A1200	Procure and Delivery Electrical Materials & Associated Accessories	In Progress	No	A1160	A1450
A1210	Procure and Delivery Waterline and Accessories	Not Started	No	A1160	A3600
A1220	Start Construction	Completed	No	A1060, A1030, A1000, A1040, A1070, A1090, A1140, A1050, A1110, A1100, A1010, A1020	A1240, A1230
A1230	Construction Survey, Staking, and Layout	Completed	No	A1220	A1720, A1400
A1240	Mobilize Manpower and Equipment (Initial)	In Progress	No	A1220	A1250
A1250	Implement Traffic Control / Warning for All Areas	In Progress	No	A1240	A1255
A1252	Clearing and Grubbing (Staging Area)	In Progress	No	A1112	A1280
A1255	Clearing and Grubbing (Bile and Pigua Area)	Not Started	No	A1250, A1080	A1260
A1260	Construct Temporary Facilities and Chainlink Fencing	Not Started	No	A1255	A1280



## Schedule Reports Showing Activity Status & Critical

### Critical

Activity ID	Activity Name	Activity Status	Critical	Successors	Predecessors
A1400	Survey, Staking, and Layout of New Utilities Final Location	In Progress	No	A1230	A1410
A1410	Excavate and Construct New Power Pedestal for House #1 @ Bile Area	In Progress	No	A1400	A1420
A1420	Relocate/Install Affected Utility Electrical Meter & Associated Accessories	Not Started	No	A1410	A1430
A1430	Relocate/Install MTS, Panelboard, Pullbox, & Other Elec/Comm Accessories	Not Started	No	A1420	A1450
A1460	Install Power Primary Riser to Existing Power Pole & Electrical Manholes	Not Started	No	A1450	A1462
A1464	Prepare Power Outage Coordination Forms	Not Started	No	A1462	A1510
A1620	Remove Old Pole and Accessories	Not Started	No	A1610	A1630
A1630	Demolition of Old Power Pedestal & Disposal	Not Started	No	A1620	A1640
A1640	Excavate and Install Handhole and Comm Shutter Box	Not Started	No	A1630	A1650, A1670
A1650	Relocate of Communication Cables & Accessories (By Docomo)	Not Started	No	A1640	A1660
A1660	Relocate of Communication Cables & Accessories (By GTA)	Not Started	No	A1650	A1670
A1670	Underground Comm. Cable Pulling and Splicing Works	Not Started	No	A1640, A1660	A1680
A1680	Disconnect Existing Communication Cables	Not Started	No	A1670	A1690
A1690	Reconnect Communications Cables to New Lines	Not Started	No	A1680	A1700
A1700	Pull-out/Remove Old Existing Cable, Conduit, and Secure	Not Started	No	A1690	A1710
A1710	Testing and Commissioning of Electrical Equipment	Not Started	No	A1700	A4000, A3760
A1770	Provide and Install Temporary Traffic Control for Phase 1	Not Started	No	A1760	A1790
A1790	Removal of Affected Trees and Stumps Pigua Area	Not Started	No	A1770	A1810
A1810	Provide Temporary Road Widening Pigua Area	Not Started	No	A1790	A2010, A1814
A1820	Provide and Install Temporary Traffic Control for Phase 2	Not Started	No	A1760, A1764	A1850, A2010
A1900	Provide and Drive Steel Sheet Piles / Temporary Earth Shoring	Not Started	No	A1890	A2090
A2010	Provide and Install Temporary Traffic Control for Phase 2	Not Started	No	A1810, A1820	A2040
A2090	Provide and Drive Steel Sheet Piles / Temporary Earth Shoring	Not Started	No	A2080, A1900	A2100
A2120	Mobilize Crane & Pile Driving Hammer to Bile Area Upstream Side	Not Started	No	A2110	A2140
A2500	Relocate and Install Temporary Traffic Controls for Phase 3	Not Started	No	A2100, A2150	A2510, A3600
A3600	Survey and Markings for Existing Waterline Location	Not Started	No	A1330, A2500, A1210	A3610
A3610	Provide Temporary Waterline Support for Pigua and Bile Area	Not Started	No	A3600	A3620

## Schedule Reports Showing Activity Status & Critical

### Critical

Activity ID	Activity Name	Activity Status	Critical	Successors	Predecessors
A3620	Provide Temporary Relocation & Support of Affected Waterline	Not Started	No	A3610	A3630
A3630	Provide & Install Service Lateral	Not Started	No	A3620	A3640
A3640	Install Fire Hydrant, Air Release Valve, & Water Meter	Not Started	No	A3630	A3650
A3650	Provide Thrust Block at WL Bend Area (Where Required)	Not Started	No	A3640	A3660
A3660	Prepare Water Outage Coordination Forms 1 & 2	Not Started	No	A3650	A3680
A3680	Water Outage 1 - Bile & Pigua Area	Not Started	No	A3660	A3690
A3690	Remove Existing 8" Dia. Waterline & Old Fire Hydrant	Not Started	No	A3680	A3700
A3700	Tapping of Lateral to Main 8" Dia. Water Line	Not Started	No	A3690	A3710
A3710	Water Enregization - 1	Not Started	No	A3700	A3720
A3720	Backfilling, Install Warning Tape, and Restoration of Affected Areas	Not Started	No	A3710	A3730
A3730	Provide and Install Valve Box and Box Cover	Not Started	No	A3720	A3740
A3740	Install 6" Fire Hydrant Bollard	Not Started	No	A3730	A3750
A3750	Chlorination, Pressure, and Leak Testing	Not Started	No	A3740	A4000, A3760
A3760	Install Transition Coupling, Bends and Thrust Blocks	Not Started	No	A3072, A3750, A1710	A3770
A3770	Install 8" Dia. DIP Permanent Waterline and Appurtenances	Not Started	No	A3760	A3780
A3780	Water Outage 2 - Bile & Pigua Area	Not Started	No	A3770	A3790
A3790	Connect Permanent 8" Dia. WL to Exist 8" Dia. WL	Not Started	No	A3780	A3800
A3800	Water Energization -2	Not Started	No	A3790	A3810
A3810	Backfilling, & Install Warning Tape	Not Started	No	A3800	A3820
A3820	Chlorination, Pressure, and Leak Testing	Not Started	No	A3810	A4000

### Yes

A1112	Archaeological Survey Requirements for Staging Area	In Progress	Yes	A1000	A1252, A1265
A1140	Prepare Material Submittals, Review, & Approval	In Progress	Yes	A1120	A1170, A1220
A1162	Prepare PC Pile Material Submittals, Review, & Approval	In Progress	Yes	A1120	A1164
A1164	Shop Fab. & Del. for Test Piles (4 for Bile & 8 for Pigua) Early Strength	Not Started	Yes	A1162	A1880, A1170
A1170	Fab. & Del. of Remaining Prestressed Concrete Piles (Bile Area)	Not Started	Yes	A1140, A1164, A1880	A1890, A1172
A1172	Fab. & Del. of Remaining Prestressed Concrete Piles (Pigua Area)	Not Started	Yes	A2070, A1170	A2080
A1265	Excavation for Archaeological Survey/Testing and Submit Final Report	Not Started	Yes	A1112	A1270
A1270	Established & Install Erosion Control / Protection	Not Started	Yes	A1265	A1280
A1280	Construction of Precast Girder Fabrication	Not Started	Yes	A1270, A1252, A1260	A1290, A1450



### Schedule Reports Showing Activity Status & Critical

**Critical**

Activity ID	Activity Name	Activity Status	Critical	Successors	Predecessors
A1290	Install Forms, and Reinforcing Steel Bars for Precast Box Beam	Not Started	Yes	A1280, A1152	A1300
A1300	Install Pre-stressing Strands to Continue End Diaphragm	Not Started	Yes	A1290, A1152	A1305
A1305	Inspection and Allow Concrete (7000 Psi)	Not Started	Yes	A1300	A1310
A1310	Testing and Allow Concrete Curing	Not Started	Yes	A1305	A1320
A1320	Remove Forms and Curing for Precast Box Beam & Painting	Not Started	Yes	A1310	A2310, A2690, A3030, A3390, A1330
A1330	Adjust Affected Swale, Install Drainage, and Headwall	Not Started	Yes	A1320	A3600, A1340
A1340	Provide Protection and Supports to Affected Existing Sewer Lines	Not Started	Yes	A1330	A1350
A1350	Relocate and Install New Sewer Manhole to new Location.	Not Started	Yes	A1340	A2190
A1360	Monitor and Record Sewer Line and Manhole Condition During Pile Driving	Not Started	Yes	A2150	A2170
A1370	Construct Bio-swale Class 1 & Class 2 (Upstream Side)	Not Started	Yes	A3460	A1380
A1380	Construct Bio-swale Class 1 & Class 2 (Downstream Side)	Not Started	Yes	A1370	A1390
A1390	Install Pavement and Raise Pavement Markings	Not Started	Yes	A3200, A1380	A4010
A1450	Fabrication of Precast/Prestressed Electrical Concrete Beam	Not Started	Yes	A1430, A1200, A1280	A1460, A1462
A1462	Construct Transformer Pad	Not Started	Yes	A1460, A1450	A1470, A1464
A1470	Excavate Trenches, and Construction of Power & Comm. Duct Bank	Not Started	Yes	A1462	A1480
A1480	Install GPA Warning Tape and Pour Flowable Backfill	Not Started	Yes	A1470	A1490
A1490	Install/Pull Electrical Underground Line/System	Not Started	Yes	A1480	A1510
A1510	Prepare Electrical Cables & Power Accessories	Not Started	Yes	A1464, A1490	A1520
A1520	Power Outage 1	Not Started	Yes	A1510	A1530
A1530	Disconnect Existing Primary Electrical Lines	Not Started	Yes	A1520	A1540
A1540	Install/Relocate Secondary Conductors	Not Started	Yes	A1530	A1542
A1542	Transfer of Transformer and Accessories	Not Started	Yes	A1540	A1550
A1550	Connect Existing Primary Lines to New Power Lines	Not Started	Yes	A1542	A1560
A1560	Relocate Overhead Streetlight	Not Started	Yes	A1550	A1570
A1570	Modify Crossarm at Old Power Poles	Not Started	Yes	A1560	A1580
A1580	Intercept Underground Service for Existing Sewer Pump Station	Not Started	Yes	A1570	A1590
A1590	Connect Power Lines to House #1	Not Started	Yes	A1580	A1600
A1600	Conduct Megger Testing	Not Started	Yes	A1590	A1610
A1610	Energization Schedule	Not Started	Yes	A1600	A1620, A2110
A1720	Provide and Install Temporary Traffic Control	Not Started	Yes	A1230	A1740

## Schedule Reports Showing Activity Status & Critical

**Critical**

Activity ID	Activity Name	Activity Status	Critical	Successors	Predecessors
A1740	Removal of Affected Trees and Stumps Bile Area	Not Started	Yes	A1720	A1760
A1760	Provide Temporary Road Widening Bile Area	Not Started	Yes	A1740	A1820, A1764, A1770
A1764	Field Fabrication of Steel Structures for Temporary Access Bridge	Not Started	Yes	A1130, A1760	A1814, A1820, A1850
A1814	Field Fabrication of Steel Structures for Temporary Access Bridge	Not Started	Yes	A1764, A1810	A2040
A1850	Mobilize Crane & Pile Driving Hammer to Bile Area Downstream Side	Not Started	Yes	A1820, A1764	A1860
A1860	Saw Cutting and Removal of Asphalt Pavement	Not Started	Yes	A1850	A1870
A1870	Excavation/Preparation for Pile Driving	Not Started	Yes	A1860	A1880
A1880	PC Pile Driving and Conduct Dynamic Pile Load Test	Not Started	Yes	A1164, A1870	A1170, A1890, A2040
A1890	Continue PC Pile Driving up to the Designed Depth (30')	Not Started	Yes	A1170, A1880	A1900, A2000, A2080
A2000	Chip Pile Head to Road Level, Backfill, and Compaction	Not Started	Yes	A1890	A2080
A2040	Mobilize Crane & Pile Driving Hammer to Pigua Area Downstream Side	Not Started	Yes	A1814, A2010, A1880	A2050
A2050	Saw Cutting and Removal of Asphalt Pavement	Not Started	Yes	A2040	A2060
A2060	Excavation/Preparation for Pile Driving	Not Started	Yes	A2050	A2070
A2070	PC Pile Driving and Conduct Dynamic Pile Load Test	Not Started	Yes	A2060	A1172, A2080
A2080	Continue PC Pile Driving up to the Designed Depth (100')	Not Started	Yes	A1172, A2070, A1890, A2000	A2090, A2170, A2100
A2100	Chip Pile Head to Road Level, Backfill, and Compaction	Not Started	Yes	A2090, A2080	A2110, A2500
A2110	Relocate and Install Temporary Traffic Controls for Phase 3	Not Started	Yes	A2100, A1610	A2120, A2130
A2130	Removal of Chainlink Fences, and Gate	Not Started	Yes	A2110	A2140
A2140	Saw Cutting and Removal of Asphalt Pavement	Not Started	Yes	A2130, A2120	A2150
A2150	Excavation/Preparation for Driving Pile	Not Started	Yes	A2140	A1360, A2170, A2500
A2170	Continue PC Pile Driving up to the Designed Depth (30')	Not Started	Yes	A2150, A2080, A1360	A2180, A2510
A2180	Excavation for Pile Cap Projection to Designed Elevations	Not Started	Yes	A2170	A2190
A2190	Chip Pile Head to Expose Reinforcement as Dowel Bars	Not Started	Yes	A2180, A1350	A2200
A2200	Backfilling, Trimming and Compaction for Pile Cap Base	Not Started	Yes	A2190	A2210
A2210	Backfill with Base Course & Compaction	Not Started	Yes	A2200	A2220
A2220	Lean Concrete Pouring at Pile Cap Base	Not Started	Yes	A2210	A2230
A2230	Installation of Fabricated Reinforcing Steel Bars	Not Started	Yes	A2220	A2240
A2240	Installation of Forms and Supports for Pile Caps	Not Started	Yes	A2230	A2250



## Schedule Reports Showing Activity Status & Critical

### Critical

Activity ID	Activity Name	Activity Status	Critical	Successors	Predecessors
A2250	Inspection and Corrections	Not Started	Yes	A2240	A2260
A2260	Concrete Pouring for Pile Caps and Take Concrete Samples	Not Started	Yes	A2250	A2270
A2270	Removal of Pile Cap Forms & Curing Application	Not Started	Yes	A2260	A2280
A2280	Demolish Temp. Access and Portion of Existing Bridge & Dispose Offsite Debris	Not Started	Yes	A2270	A2290
A2290	Excavation, Benching, and Trimming Portion of Soil for Riprap Location	Not Started	Yes	A2280	A2300
A2300	Construct Portion of Grouted Riprap Slope Protection	Not Started	Yes	A2290	A2310
A2310	Erection of Fabricated Bridge Box Girders into Place	Not Started	Yes	A2300, A1320	A2320
A2320	Install 7/8" Dia. Transverse Tie Rod Anchorage at Beam Mid Diaphragm	Not Started	Yes	A2310	A2330
A2330	Grout Application at Beam Mid Diaphragm where required	Not Started	Yes	A2320	A2340
A2340	Forms, Reinforcements, and Concrete Pouring for CIP End Diaphragm	Not Started	Yes	A2330	A2350
A2350	Forms, Rebar, and Concrete End Box Beam Bridge Barrier	Not Started	Yes	A2340	A2360
A2360	Install 6" Dia. PVC Perforated Drain Pipe	Not Started	Yes	A2350	A2370
A2370	Install 5/8" Thick Geocomposite Drain Board	Not Started	Yes	A2360	A2380
A2380	Backfilling and Compaction Pile Cap Area	Not Started	Yes	A2370	A2390
A2390	Excavation, Trimming, and Leveling Portion of Concrete Abutment	Not Started	Yes	A2380	A2400
A2400	Lay Basecourse, Leveling, and Compaction for Portion of Concrete Abutment	Not Started	Yes	A2390	A2410
A2410	Install Forms, and Reinforcing Steel Bars for Portion of Concrete Abutment	Not Started	Yes	A2400	A2420
A2420	Concrete Pouring for for Portion of Concrete Abutment	Not Started	Yes	A2410	A2430
A2430	Forms, Rebars, and Pour Concrete for Wing Wall	Not Started	Yes	A2420	A2440
A2440	Roughen and Water Blast Top Surface of Box Beam in Transverse Direction	Not Started	Yes	A2430	A2450
A2450	Aggregate Base, Grading C, 8-Inch Depth	Not Started	Yes	A2440	A2460
A2460	Tack Coat and Hot Mix Asphalt (HMA) Concrete Pavement Application	Not Started	Yes	A2450	A2470
A2470	Hot Mix Asphalt (HMA) Concrete Pavement, Friction Course, 1-inch Depth	Not Started	Yes	A2460	A2480
A2480	Install Guardrail Anchorage Trailing End	Not Started	Yes	A2470	A2490
A2490	Install Guardrail (Type W & Type T)	Not Started	Yes	A2480	A2880
A2510	Mobilize Crane & Pile Driving Hammer to Pigua Area Upstream Side	Not Started	Yes	A2500, A2170	A2520
A2520	Saw Cutting and Removal of Asphalt Pavement	Not Started	Yes	A2510	A2530
A2530	Excavation/Preparation for Driving Pile	Not Started	Yes	A2520	A2550

## Schedule Reports Showing Activity Status & Critical

### Critical

Activity ID	Activity Name	Activity Status	Critical	Successors	Predecessors
A2550	Continue PC Pile Driving up to the Designed Depth (100')	Not Started	Yes	A2530	A2560
A2560	Excavation for Pile Cap Projection to Designed Elevations	Not Started	Yes	A2550	A2570
A2570	Chip Pile Head to Expose Reinforcement as Dowel Bars	Not Started	Yes	A2560	A2580
A2580	Backfilling, Trimming and Compaction for Pile Cap Base	Not Started	Yes	A2570	A2590
A2590	Backfill with Base Course & Compaction for Pile Cap Base	Not Started	Yes	A2580	A2600
A2600	Lean Concrete Pouring at Pile Cap Base	Not Started	Yes	A2590	A2610
A2610	Installation of Fabricated Reinforcing Steel Bars for Pile Caps	Not Started	Yes	A2600	A2620
A2620	Installation of Forms and Supports for Pile Caps	Not Started	Yes	A2610	A2630
A2630	Inspection and Corrections	Not Started	Yes	A2620	A2640
A2640	Concrete Pouring for Pile Caps and Take Concrete Samples	Not Started	Yes	A2630	A2650
A2650	Removal of Pile Cap Forms & Curing Application	Not Started	Yes	A2640	A2660
A2660	Demolish Temp. Access and Portion of Existing Bridge & Dispose Offsite Debris	Not Started	Yes	A2650	A2670
A2670	Excavation, Benching, and Trimming Portion of Soil for Riprap Location	Not Started	Yes	A2660	A2680
A2680	Construct Portion of Grouted Riprap Slope Protection	Not Started	Yes	A2670	A2690
A2690	Erection of Fabricated Bridge Box Girders into Place	Not Started	Yes	A2680, A1320	A2700
A2700	Install 7/8" Dia. Transverse Tie Rod Anchorage at Beam Mid Diaphragm	Not Started	Yes	A2690	A2710
A2710	Grout Application at Beam Mid Diaphragm where required	Not Started	Yes	A2700	A2720
A2720	Forms, Reinforcements, and Concrete Pouring for CIP End Diaphragm	Not Started	Yes	A2710	A2730
A2730	Forms, Rebar, and Concrete End Box Beam Bridge Barrier	Not Started	Yes	A2720	A2740
A2740	Install 6" Dia. PVC Perforated Drain Pipe	Not Started	Yes	A2730	A2750
A2750	Install 5/8" Thick Geocomposite Drain Board	Not Started	Yes	A2740	A2760
A2760	Backfilling and Compaction Pile Cap Area	Not Started	Yes	A2750	A2770
A2770	Excavation, Trimming, and Leveling Portion of Concrete Abutment	Not Started	Yes	A2760	A2780
A2780	Lay Basecourse, Leveling, and Compaction for Portion of Concrete Abutment	Not Started	Yes	A2770	A2790
A2790	Install Forms, and Reinforcing Steel Bars for Portion of Concrete Abutment	Not Started	Yes	A2780	A2800
A2800	Concrete Pouring for for Portion of Concrete Abutment	Not Started	Yes	A2790	A2810
A2810	Forms, Rebars, and Pour Concrete for Wing Wall	Not Started	Yes	A2800	A2820

### Schedule Reports Showing Activity Status & Critical

**Critical**

Activity ID	Activity Name	Activity Status	Critical	Successors	Predecessors
A2820	Roughen and Water Blast Top Surface of Box Beam in Transverse Direction	Not Started	Yes	A2810	A2830
A2830	Aggregate Base, Grading C, 8-Inch Depth	Not Started	Yes	A2820	A2840
A2840	Tack Coat and Hot Mix Asphalt (HMA) Concrete Pavement Application	Not Started	Yes	A2830	A2850
A2850	Hot Mix Asphalt (HMA) Concrete Pavement, Friction Course, 1-inch Depth	Not Started	Yes	A2840	A2860
A2860	Install Guardrail Anchorage Trailing End	Not Started	Yes	A2850	A2870
A2870	Install Guardrail (Type W & Type T)	Not Started	Yes	A2860	A3240
A2880	Relocate and Install Temporary Traffic Controls for Phase 4	Not Started	Yes	A2490	A2890
A2890	Remove Steel Sheet Piles and Demolish Temporary Access Bridge	Not Started	Yes	A2880	A2900
A2900	Excavation for Pile Cap Projection to Designed Elevations	Not Started	Yes	A2890	A2910
A2910	Chip Pile Head to Expose Reinforcement as Dowel Bars	Not Started	Yes	A2900	A2920
A2920	Backfilling, Trimming and Compaction for Pile Cap Base	Not Started	Yes	A2910	A2930
A2930	Backfill with Base Course & Compaction	Not Started	Yes	A2920	A2940
A2940	Lean Concrete Pouring at Pile Cap Base	Not Started	Yes	A2930	A2950
A2950	Installation of Fabricated Reinforcing Steel Bars for Pile Caps	Not Started	Yes	A2940	A2960
A2960	Installation of Forms and Supports for Pile Caps	Not Started	Yes	A2950	A2970
A2970	Inspection and Corrections	Not Started	Yes	A2960	A2980
A2980	Concrete Pouring for Pile Caps and Take Concrete Samples	Not Started	Yes	A2970	A2990
A2990	Removal of Pile Cap Forms & Curing Application	Not Started	Yes	A2980	A3000
A3000	Demolish Remaining Existing Bridge and Dispose Debris to Approved Site	Not Started	Yes	A2990	A3010
A3010	Excavation, Benching, and Trimming Remaining Soil for Riprap Location	Not Started	Yes	A3000	A3020
A3020	Construct Remaining Grouted Riprap Slope Protection	Not Started	Yes	A3010	A3030
A3030	Erection / Installation of Remaining Existing Box Girders into Place	Not Started	Yes	A3020, A1320	A3040
A3040	Install 7/8" Dia. Transverse Tie Rod Anchorage at Beam Mid Diaphragm	Not Started	Yes	A3030	A3050
A3050	Grout Application at Beam Mid Diaphragm where required	Not Started	Yes	A3040	A3060
A3060	Forms, Reinforcements, and Concrete Pouring for CIP End Diaphragm	Not Started	Yes	A3050	A3070
A3070	Forms, Rebar, and Concrete End Box Beam Bridge Barrier	Not Started	Yes	A3060	A3080, A3072
A3072	Install Fabricated Utility Raceway	Not Started	Yes	A3070	A3080, A3760
A3080	Install 6" Dia. PVC Perforated Drain Pipe	Not Started	Yes	A3070, A3072	A3090



### Schedule Reports Showing Activity Status & Critical

**Critical**

Activity ID	Activity Name	Activity Status	Critical	Successors	Predecessors
A3090	Install 5/8" Thick Geocomposite Drain Board	Not Started	Yes	A3080	A3100
A3100	Backfilling and Compaction Pile Cap Area	Not Started	Yes	A3090	A3110
A3110	Excavation, Trimming, and Leveling of Concrete Abutment @ Downstream Side	Not Started	Yes	A3100	A3120
A3120	Lay Basecourse, Leveling, and Compaction for Concrete Abutment	Not Started	Yes	A3110	A3130
A3130	Install Forms, and Reinforcing Steel Bars for Concrete Abutment	Not Started	Yes	A3120	A3140
A3140	Concrete Pouring for the Remaining Concrete Abutment	Not Started	Yes	A3130	A3150
A3150	Forms, Rebars, and Pour Concrete for Wing Wall	Not Started	Yes	A3140	A3160
A3160	Roughen and Water Blast Top Surface of Box Beam in Transverse Direction	Not Started	Yes	A3150	A3170
A3170	Aggregate Base, Grading C, 8-Inch Depth	Not Started	Yes	A3160	A3180
A3180	Preparation of Existing Asphalt Edge and New Asphalt Pavement Joints	Not Started	Yes	A3170	A3190
A3190	Tack Coat and Hot Mix Asphalt (HMA) Concrete Pavement Application	Not Started	Yes	A3180	A3200
A3200	Hot Mix Asphalt (HMA) Concrete Pavement, Friction Course, 1-inch Depth	Not Started	Yes	A3190	A1390, A3220
A3220	Install Guardrail Anchorage Trailing End	Not Started	Yes	A3200	A3230
A3230	Install Guardrail (Type W & Type T)	Not Started	Yes	A3220	A4000
A3240	Relocate and Install Temporary Traffic Controls for Phase 4	Not Started	Yes	A2870	A3250
A3250	Remove Steel Sheet Piles and Demolish Temporary Access Bridge	Not Started	Yes	A3240	A3260
A3260	Excavation for Pile Cap Projection to Designed Elevations	Not Started	Yes	A3250	A3270
A3270	Chip Pile Head to Expose Reinforcement as Dowel Bars	Not Started	Yes	A3260	A3280
A3280	Backfilling, Trimming and Compaction for Pile Cap Base	Not Started	Yes	A3270	A3290
A3290	Backfill with Base Course & Compaction for Pile Cap Base	Not Started	Yes	A3280	A3300
A3300	Lean Concrete Pouring at Pile Cap Base	Not Started	Yes	A3290	A3310
A3310	Installation of Fabricated Reinforcing Steel Bars for Pile Caps	Not Started	Yes	A3300	A3320
A3320	Installation of Forms and Supports for Pile Caps	Not Started	Yes	A3310	A3330
A3330	Inspection and Corrections	Not Started	Yes	A3320	A3340
A3340	Concrete Pouring for Pile Caps and Take Concrete Samples	Not Started	Yes	A3330	A3350
A3350	Removal of Pile Cap Forms & Curing Application	Not Started	Yes	A3340	A3360
A3360	Demolish Remaining Existing Bridge and Dispose Debris to Approved Site	Not Started	Yes	A3350	A3370
A3370	Excavation, Benching, and Trimming Remaining Soil for Riprap Location	Not Started	Yes	A3360	A3380



### Schedule Reports Showing Activity Status & Critical

Critical

Activity ID	Activity Name	Activity Status	Critical	Successors	Predecessors
A3380	Construct Remaining Grouted Riprap Slope Protection	Not Started	Yes	A3370	A3390
A3390	Erection / Installation of Remaining Existing Box Girders into Place	Not Started	Yes	A3380, A1320	A3400
A3400	Install 7/8" Dia. Transverse Tie Rod Anchorage at Beam Mid Diaphragm	Not Started	Yes	A3390	A3410
A3410	Grout Application at Beam Mid Diaphragm where required	Not Started	Yes	A3400	A3420
A3420	Forms, Reinforcements, and Concrete Pouring for CIP End Diaphragm	Not Started	Yes	A3410	A3430
A3430	Forms, Rebar, and Concrete End Box Beam Bridge Barrier	Not Started	Yes	A3420	A3432
A3432	Install Fabricated Utility Raceway	Not Started	Yes	A3430	A3440
A3440	Install 6" Dia. PVC Perforated Drain Pipe	Not Started	Yes	A3432	A3450
A3450	Install 5/8" Thick Geocomposite Drain Board	Not Started	Yes	A3440	A3460
A3460	Backfilling and Compaction Pile Cap Area	Not Started	Yes	A3450	A1370, A3470
A3470	Excavation, Trimming, and Leveling of Concrete Abutment @ Downstream Side	Not Started	Yes	A3460	A3480
A3480	Lay Basecourse, Leveling, and Compaction for Concrete Abutment	Not Started	Yes	A3470	A3490
A3490	Install Forms, and Reinforcing Steel Bars for Concrete Abutment	Not Started	Yes	A3480	A3500
A3500	Concrete Pouring for the Remaining Concrete Abutment	Not Started	Yes	A3490	A3510
A3510	Forms, Rebars, and Pour Concrete for Wing Wall	Not Started	Yes	A3500	A3520
A3520	Roughen and Water Blast Top Surface of Box Beam in Transverse Direction	Not Started	Yes	A3510	A3530
A3530	Aggregate Base, Grading C, 8-Inch Depth	Not Started	Yes	A3520	A3540
A3540	Preparation of Existing Asphalt Edge and New Asphalt Pavement Joints	Not Started	Yes	A3530	A3550
A3550	Tack Coat and Hot Mix Asphalt (HMA) Concrete Pavement Application	Not Started	Yes	A3540	A3560
A3560	Hot Mix Asphalt (HMA) Concrete Pavement, Friction Course, 1-inch Depth	Not Started	Yes	A3550	A3580
A3580	Install Guardrail Anchorage Trailing End	Not Started	Yes	A3560	A3590
A3590	Install Guardrail (Type W & Type T)	Not Started	Yes	A3580	A4000
A4000	Restoration of Affected Structures and Clean-up	Not Started	Yes	A3230, A1710, A3750, A3590, A3820	A4010
A4010	Establish Punch-out Items	Not Started	Yes	A4000, A1390	A4020
A4020	Punchlists Inspection and Corrections	Not Started	Yes	A4010	A4030
A4030	Final Inspection and Corrections	Not Started	Yes	A4020	A4040
A4040	Acceptance and Turn-over to Government	Not Started	Yes	A4030	A4050
A4050	Project Complete (CCD = March 29, 2016)	Not Started	Yes	A4040	

c

# Exhibit c

# **Korando Correspondence**

Dated May 27, 2015

Transmittal/Review/Approval

Letter: Bile/Pigua Bridge Project

GU-NH-NBIS(007)

*GH*  
*Greggo*

<b>Transmittal/Review/Approval</b>		FILE NAME: Letter: Bile/Pigua Bridge Project GU-NH-NBIS(007)	DATE: 5/28/2015		
CONTRACT NO.: GU-NH-NBIS(007)		TITLE: (Fill in Project Title/Location Here) Bile / Pigua Bridge Replacement (Construction Phase), Route 4, Merizo, Guam			
FROM (CONTRACTOR): Korando Corporation		TO: Mr. Glenn Leon Guerrero / DPW	SUBMITTAL NO.: SPECS. SECTION:		
ENCL. NO.	NO. OF COPIES	DESCRIPTION	SPEC.SEC./PARA	SCHEDULE ACTIVITY NO.	CQC CODE
		Bile & Pigua Bridge Replacement (Construction Phase)			
1	2	Letter: Bile/Pigua Bridge Project GU-NH-NBIS(007)			
2	18	Existing Bridge Assessment Report			
DATE NEEDED BY:					
TRANSMITTED FOR: <input type="checkbox"/> APPROVAL <input type="checkbox"/> CLARIFICATION <input type="checkbox"/> SELECTION <input checked="" type="checkbox"/> RECORD <input type="checkbox"/> VARIANCE					
It is hereby certified that the material submitted herein conforms to contract requirements and can be installed in the allocated spaces.		CONTRACTOR'S REPRESENTATIVE NAME/TITLE Ricarte Bisquera / QC Manager	SIGNATURE:		
Received By (Print Name & Sign)/Date/Time:      Mr. Glenn Leon Guerrero / DPW      5/28/2015					
FROM:		SIGNATURE:		DATE:	
TO: Mr. Glenn Leon Guerrero / DPW		For review/comment ( ) copies of enclosures forwarded. RETURN WITHIN ( ) WORKING DAYS, unless submittal is for record/info purposes only and there are no adverse comments.			
Received By (Print Name & Sign)/Date/Time:      Mr. Glenn Leon Guerrero / DPW      5/28/2015					
FROM:		TO:		DATE:	
RECOMMEND / Enclosure(s) is (are)					
<input type="checkbox"/> No Exception Taken (NET)		<input type="checkbox"/> Rejected/Resubmit (Rej/R)		<input type="checkbox"/>	
<input type="checkbox"/> Exceptions As Noted (EAN)		<input type="checkbox"/> No Action Required (NAR)		<input type="checkbox"/>	
<input type="checkbox"/> Revise/Resubmit (Rev/R)		<input type="checkbox"/> Not Subject To Review (NSTR)			
REMARKS:					
<input type="checkbox"/> Copies of encls returned:		SIGNATURE:			
Copy to:					
Received By (Print Name & Sign)/Date/Time:					





May 27, 2015

Department of Public Works  
542 N. Marine Drive Corps.  
Tamuning, Guam 96913  
Attn: Director- Glenn Leon Guerrero

Re: Bile/Pigua Bridge Project GU-NH-NBIS (007)

Dear Mr. Glenn Leon Guerrero,

Respectfully, we understand the concerns regarding the delay on the Bile-Pigua project. We would like to assure you that Korando Corporation is going to provide the best solution to recover the loss of time that has accumulated in the past few months. We understand there seems to be no accomplishment or physical construction movement for the Bridge project. Behind the scenes we are working on this. We are committed to the effort of bringing the project up to where we should be.

And, we call your attention to the following issues we are having with for the Bile-Pigua Bridge project.

1<sup>st</sup> - Building permit received on November 2014. Yes, a building permit was dated and received. However, individual agency compliance requirement that permits actual start of work was not completed until 02/26/2015. This was part of the set back on compliance requirements which provided a delay for actual work to start at the construction site. And, that the project document is fair to state that these agency compliance associated with permitting is not included in the 450 contract calendar days.

2<sup>nd</sup> - Recovery Schedule- (Alternate Phasing issue) recovery schedule has been submitted for review and are awaiting approval to proceed with this phasing.

3<sup>rd</sup> - Resident Complaints- We have encountered complaints from a local resident that should Korando proceed with its construction, he will be pressing legal charges. This issue was submitted on RFI #9 to Stanley Consultants. Korando received a letter from DPW dated May 20, 2015 acknowledging and resolving the complaint issue.

4<sup>th</sup> - Alternate Phasing Plan RFI #11 Stanley Consultants response letter to Korando dated May 5, 2015. It was stated by Stanley Consultants that we must preserve and protect the existing structures as indicated in Section 107.02 of FP-03. Our main concern for the alternate phasing is the efficiency of the bridge in general and the safety of the public, in particular. Korando Corporation has researched from prior data back in 2008 from Geo-Engineering & Testing, Inc with regards to the structural integrity that the construction of a temporary single lane bridge be a temporary interim solution. And, to date, an updated research from J.M Aquino and Associates indicated that the current temporary bridge is not safe. And, the same findings recommend an alternate phasing plan be explored instead of the current phasing plan.

We hope you are able to consider that this is not a means of convenience for Korando Corporation but the efficiency of the existing bridge structures and welfare and safety to the public. Korando Corporation is handling the construction of the bridges as a main priority to the Government of Guam and its people. We welcome any suggestions or references that you are able to offer with the utmost respect.

Sincerely,



Byong Ho Kim  
President

J.M. AQUINO, PC

Consulting Engineers

278 Scout Marine Corps Drive, Suite 206 Hengi Plaza, Tamuning 96913  
P.O. Box 6052 Tamuning, Guam 96931

Tel 647-5124 Fax 647-5123  
e-mail: johnny.a@jmapc.net

**STRUCTURAL ASSESSMENT REPORT**  
**FOR EXISTING BILE & PIGUA STEEL BRIDGE**

MERIZO, GUAM



Signature and date: 5-26-15

## ANALYSIS & DESIGN CRITERIA

### A. REFERENCES:

1. American Association of State Highways & Transportation Officials, AASHTO 2012
2. American Institute of Steel Construction, AISC 2005

### B. MATERIALS:

Structural Steel Shapes & Plates .....36 ksi (assumed)  
Deck plates (3/4" thick)

### C. LOADS:

#### CASE 1:

- a. HS20-44 Truck Load
- b. Lane Load  
 $P = 18 \text{ kips (for Moment)}$   
 $= 26 \text{ kips (for Shear)}$   
 $w = 0.64 \text{ kips/ft}$

#### CASE 2:

- a. Lowboy Trailer + Crane Counterweight  
Truck Tractor Weight = 15 kips  
Lowboy Trailer Weight = 17 kips  
Crane Counterweight = 74 kips  
Mobile Crane = 63 kips

Lowboy Trailer + Crane Counterweight = 91 Kips (govern design)

### 2. Seismic Load

Design Parameters :

Site Class = 'E'

$F_{pga} = 1.08$  ( Site Factor @ Zero-Period on Acceleration Spectrum )

$F_a = 0.90$  ( Site Factor for Short-Period Range of Acceleration Spectrum )

$F_v = 2.40$  ( Site Factor for Long-Period Range of Acceleration Spectrum )

$S_s = 1.50g$  ( Mapped Spectral Response Acceleration @ 0.20-sec. period )

$S_1 = 0.60g$  ( Mapped Spectral Response Acceleration @ 1.0-sec. period )

PGA = 0.34g ( Peak Ground Acceleration )



## **EXECUTIVE SUMMARY**

The following report presents the structural assessment of the superstructures (structural steel stringers and steel plates) of the two existing bridges; namely, Bile and Pigua Bridge. Both bridges are located next to each other along Route 4 Road in Merizo. We understand that existing bridge substructure are structurally sufficient to support the existing and temporary bridges.

Results of the analysis confirmed that the existing bridge superstructures are structurally inadequate to support the two design load Cases 1(HS20-44) and 2 (Lowboy Trailer + Crane Counterweight). AASHTO LRFD requirements are not met.

## **DISCUSSION:**

### **CASE 1: (HS20-44 TRUCK LOAD AND LANE LOAD)**

The design loads are the various combinations of HS20-44 Truck Load , Lane Load and Seismic Load. The dead load weight of 3/4" thick deck plates and I-beam stringers were also considered in the analysis. Stringer section properties, spacing, and actual dimensions of the existing bridge were measured for use in the evaluation. Load and Resistance Factor Design (LRFD) was used to determine the strength capacity of the superstructure bridge components. The design stresses were then compared with the AASHTO allowable stresses (moment and shear) to find out whether the structure is adequate or not.

### **CASE 2: (LOWBOY TRAILER + CRANE COUNTERWEIGHT)**

The design loads are the combination of Lowboy Trailer Weight + Crane Counterweight and Seismic Load. The various vertical design loads were provided to us by the Contractor.

CASE 1 :

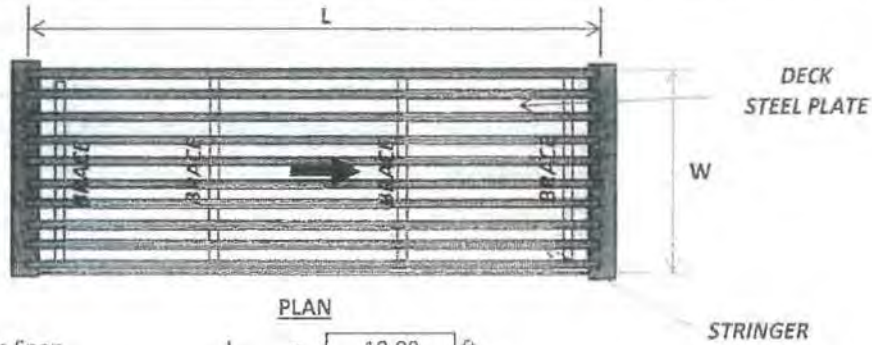

	PLAN		
Bridge Span	L	=	19.00 ft
Bridge Width	W	=	12.00 ft
Live Load Type		=	HS20-44

**A. LOADINGS**

LANE LOAD

Concentrated Load	=	18.00 kips	AASHTO 3.6.1.2.4 ( for Moment )
		26.00 kips	( for Shear )
Uniform Load	=	0.64 kips/ft	

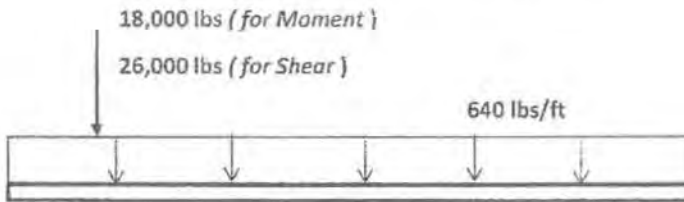

LOADING DIAGRAM

TRUCK LOAD

HS20-44	=	72.00 kips	AASHTO 3.6.1.2.2 ( Total Weight of Vehicle )
Axle Width	=	6.00 ft	
Axle Spacing	=	14.00 ft	( Front Wheel to 1st Rear Wheel )
v	=	14.00 ft	( 1st Rear Wheel to 2nd Rear Wheel )



## B. DECK PLATE DESIGN

Deck Plate Properties:

Plate Thickness	$t$	=	0.75	in
Plate Width	$v$	=	20.00	in
Moment of Inertia	$I$	=	0.70	in <sup>4</sup>
Section Modulus	$S$	=	1.88	in <sup>3</sup>
Yield Strength	$F_y$	=	36.00	ksi

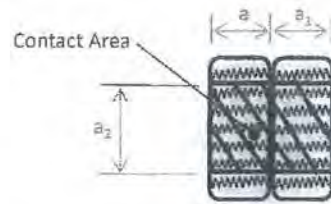

Truck Wheel

Wheel Contact Width	$a_1$	=	10.0	in
Wheel Contact Length	$a_2$	=	20.0	in

AASHTO 3.6.1.2.5

Dyn. Load Allowance	I.M.	=	0.33
---------------------	------	---	------

AASHTO 3.6.2

Deadload

Deck Plate Weight	$w_p$	=	0.05	kips/ft
-------------------	-------	---	------	---------

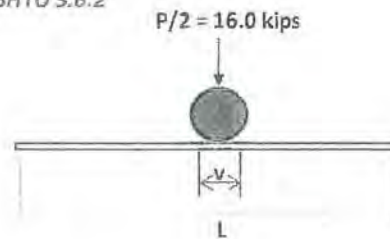

Liveload

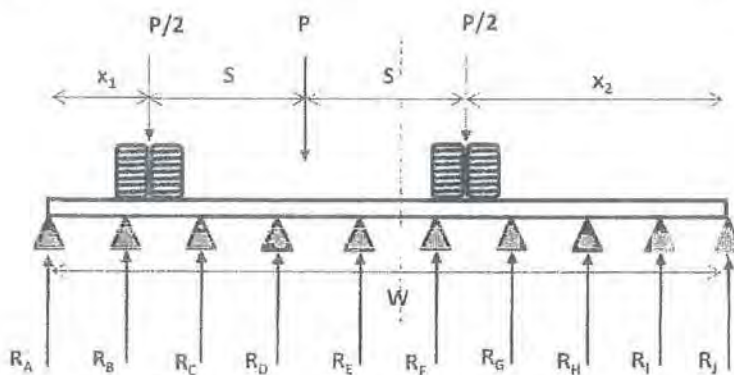

$P$	=	32.00	kips
$P/2$	=	16.00	kips

$W$	=	12.00	ft
$S$	=	3.00	ft
$x_1$	=	0.67	ft
$x_2$	=	5.33	ft

Reactions

$R_A$	=	6.393	kips	$R_F$	=	-0.180	kips	$R_{TOT} = R_A + R_B + \dots + R_J$ 32.0 kips
$R_B$	=	11.633	kips	$R_G$	=	16.048	kips	
$R_C$	=	-2.563	kips	$R_H$	=	-0.013	kips	
$R_D$	=	0.000	kips	$R_I$	=	0.003	kips	
$R_E$	=	0.680	kips	$R_J$	=	-0.001	kips	

Deadload Moment	$M_{DL}$	=	0.01	kips-ft
-----------------	----------	---	------	---------

Liveload Moment	$M_{LL}$	=	4.26	kips-ft
-----------------	----------	---	------	---------

Factored Moments :

$$M_u = 1.25M_{DL} + 1.75(1 + I.M.)(M_{LL}) = 9.93 \text{ kips-ft} \quad (\text{STRENGTH I\_ AASHTO 3.4.1})$$

Moment Capacity :

$$\phi Mn = \phi F_y Z_x = 7.59 \text{ kips-ft}$$

where :

$\phi$	=	0.90
$F_y$	=	36.00 ksi
$Z_x$	=	1.5 ( $S_x$ )
	=	2.81 in <sup>3</sup>

$$M_u > \phi Mn \quad (\text{NOT OK!!!})$$

### C. STRINGER DESIGN

Yield Strength  $F_y = 36.00$  ksi  
 Mod. of Elasticity  $E = 29000$  ksi

#### Stringer Properties: Wide Flange

Depth	$d$	=	6.00	in
Flange Width	$b_f$	=	6.00	in
Flange thickness	$t_f$	=	0.25	in
Web thickness	$t_w$	=	0.25	in
Area	$A$	=	4.38	in <sup>2</sup>
Moment of Inertia	$I_x$	=	65.36	in <sup>4</sup>
	$I_y$	=	265.01	in <sup>4</sup>
Radius of Gyration	$r_x$	=	3.87	in
	$r_y$	=	7.78	in

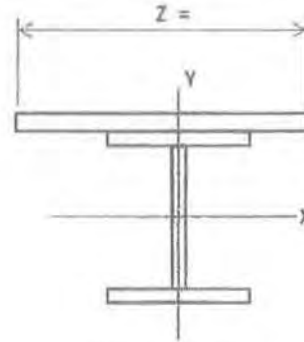

WIDE FLANGE SECTION

### LOADINGS

#### A. Deadload

Deck Plate Weight	$w_1$	=	0.06	kips/ft/stringer
Stringer Weight	$w_2$	=	0.01	kips/ft/stringer
	$w_{TOT}$	=	0.08	kips/ft/stringer

#### B. Liveload

#### LANE LOAD:

AASHTO 3.6.1.2.4

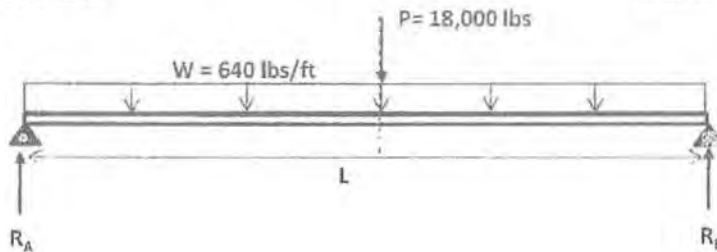

#### Maximum Moment :

Deadload Moment	$M_{DL}$	=	3.44	kips-ft
Liveload Moment	$M_{LL}$	=	114.38	kips-ft



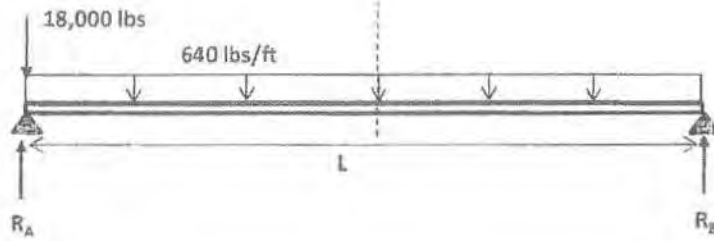

*Maximum Shear :*

Deadload Shear  $V_{DL} = 0.72 \text{ kips}$

Liveload Shear  $V_{LL} = 24.08 \text{ kips}$

*TRUCK LOAD :*

*AASHTO 3.6.1.2.2*

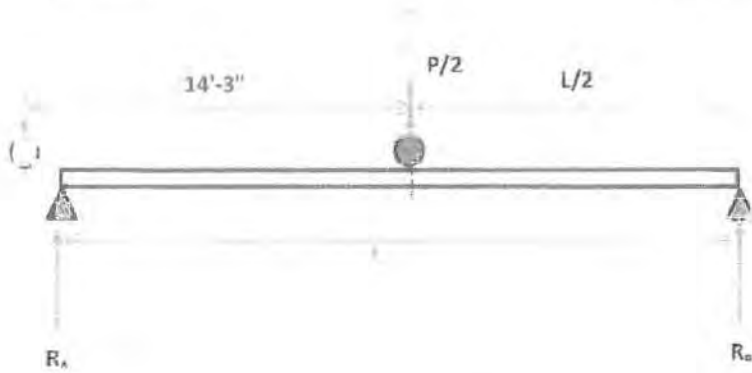

Reactions

$R_a = 8.00 \text{ kips}$        $R_b = 8.00 \text{ kips}$

$P/2 = 16.00 \text{ kips}$

*Maximum Moment:*

Deadload Moment  $M_{DL} = 3.44 \text{ kips-ft}$

Liveload Moment  $M_{LL} = 76.00 \text{ kips-ft}$

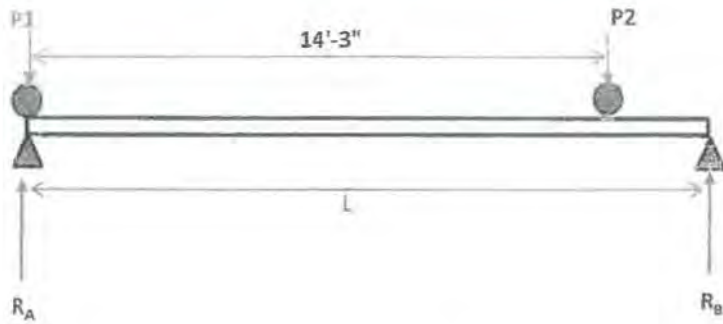

Reactions  
 $R_a = 20.00$  kips       $R_b = 12.00$  kips

*Maximum Shear :*

Deadload Shear       $V_{DL} = 0.72$  kips  
 Liveload Shear       $V_{LL} = 20.00$  kips

**C. Seismic Load**

AASHTO 3.10

Deck Weight	$W_d = 0.08$ kip/ft
Stringer Weight	$W_s = 0.01$ kip/ft
Total Dead Weight	$W_t = 0.10$ kip/ft
Moment of Inertia	$I_x = 65.36$ in <sup>4</sup>
	$I_y = 265.01$ in <sup>4</sup>
Stringer Section Area	$A = 4.38$ in <sup>2</sup>
Mod. Of Elasticity	$E = 29000$ ksi
Bridge Span	$L = 19.00$ ft

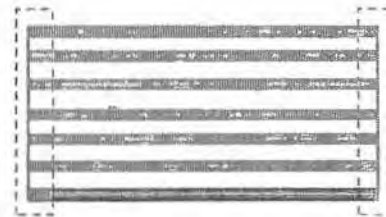
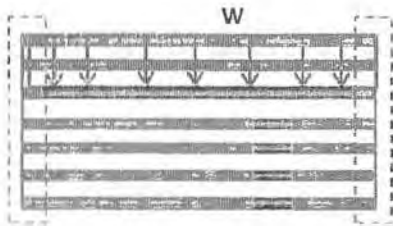

			TRANSVERSE	LONGITUDINAL	
			5WL <sup>4</sup> / 384EI	PL / AE	
Unit Deflection	$\delta$	=	0.0017	0.02156	ft/kip
Stiffness	$k = (1/\delta)$	=	597.58	46.37	kip/ft
Static Displacement	$V_s = (PL/k)$	=	0.03	0.4097	ft
Single Mode Factors	$\alpha = (V_s L)$	=	0.60	7.7848	ft <sup>2</sup>
	$\beta = (\alpha Wt)$	=	0.06	0.75	ft- kip
	$\gamma = (\beta V_s)$	=	0.00185	0.30797	ft <sup>2</sup> - kip
Period of Oscillation	$T = (2\pi\gamma/Pg\alpha)$	=	0.06	0.22	sec
Site Class	S	=	E		
	$F_{pga}$ (Site Class E)	=	1.08		
	$F_a$ (Site Class E)	=	0.90		
	$F_v$ (Site Class E)	=	2.40		
	$S_s$ (Guam)	=	1.50		
	$S_1$ (Guam)	=	0.60		
	PGA (Guam)	=	0.34		
	$T_M = T$	=	0.06	0.22	sec
	$A_s = F_{pga} \times PGA$	=	0.37		
	$S_{DS} = F_a \times S_s$	=	1.35		
	$S_{D1} = F_v \times S_1$	=	1.44		
	$T_0 = 0.2 \times S_1$	=	0.12		sec
	$T_s = S_{D1}/S_{DS}$	=	1.07		sec
	$C_{SM} = A_s + (S_{DS}/A_s)/(T_M/T_0)$	=	2.29	0.90	
	$W = Wt \times L$	=	1.83		kips
	$P_T \ \& \ P_L = C_{SM} \times W$	=	4.20	1.66	kips

#### FACTORED MOMENTS

##### A. Strong Axis ( X Axis )

$$M_{DL} = 3.44 \text{ kips-ft}$$

$$M_{LL} = \text{Truck + Lane Load} = 190.38 \text{ kips-ft}$$

##### B. Weak Axis ( Y - Axis )

$$M_{EQ} = P_T \times L / 4 = 19.95 \text{ kips-ft}$$

With Seismic :

$$M_{UX} = 1.25M_{DL} + 0.50(1+I.M.)(M_{LL}) \quad (\text{EXTREME EVENT I\_AASHTO 3.4.1})$$

$$= 130.90 \text{ kips-ft}$$

$$M_{UY} = 1.0 M_{EQ} = 19.95 \text{ kips-ft}$$

No Seismic :

$$M_{UX} = 1.25M_{DL} + 1.75(1+I.M.)(M_{LL}) \quad (\text{STRENGTH I\_AASHTO 3.4.1})$$

$$= 130.90 \text{ kips-ft}$$

**FLEXURE CHECK ( BIAXIAL ) :**

**Flexural Strength**

Check Length:

$$L_b = \frac{L}{4} = \boxed{4.75} \text{ ft}$$

$$L_p = 1.76 r_y (E/F_y)^{0.50} = \boxed{32.40} \text{ ft}$$

Check Compactness :

$$\lambda_f = \frac{bf}{2tf} = \boxed{2.400}$$

$$\lambda_{pf} = 0.38 \left( \frac{E}{F_y} \right)^{0.5} = \boxed{10.785}$$

Since

$$L_b < L_p$$

$$\lambda_f < \lambda_{pf}$$

Then :

$$\phi M_{nx} = \phi F_y Z_x = \boxed{45.08} \text{ kips-ft}$$

where :

$$\phi = \boxed{0.90}$$

$$Z_x = \boxed{16.69} \text{ in}^3$$

**Section Check**

With Seismic

$$\frac{M_{ux}}{\phi M_{nx}} + \frac{M_{uy}}{\phi M_{ny}} \leq \boxed{1.0}$$

where:

$$Z_y = \boxed{52.59} \text{ in}^3$$

$$\phi M_{ny} = \phi F_y Z_y = \boxed{141.98} \text{ kip-ft}$$

$$\frac{130.90}{45.08} + \frac{19.95}{141.98} = \boxed{3.04} \text{ ( NOT OK!!! )}$$

No Seismic :

$$M_{ux} > \phi M_{nx} \text{ ( NOT OK!!! )}$$

**AXIAL & FLEXURE CHECK :**

$$kL/r = \boxed{29.295}$$

$$4.71 (E/F_y)^{0.5} = \boxed{133.681}$$

$$F_e = \frac{\pi^2 E}{(kL/r)^2} = \boxed{333.51} \text{ ksi}$$

$$kL/r < 4.71 (E/F_y)^{0.5}$$

$$F_e > 0.44 F_y$$

Therefore :

$$F_{cr} = [0.658^{(F_y/F_e)}] F_y = \boxed{34.410} \text{ ksi}$$

$$P_n = F_{cr} A_g = \boxed{150.543} \text{ kips}$$



$$\left( \frac{P_L}{2\phi P_n} \right) + \left( \frac{M_{ux}}{\phi M_{nx}} \right) \leq \boxed{1.0}$$

$$\left( \frac{1.66}{270.98} \right) + \left( \frac{130.90}{45.08} \right) = \boxed{2.91} \text{ (NOT OK!!!)}$$

**SHEAR CHECK :**

**Factored Shear**

$$V_{DL} = \boxed{0.72} \text{ kips}$$

$$V_{LL} = \boxed{20.00} \text{ kips}$$

$$V_{Lx} = 1.25V_{DL} + 1.75(1+I.M.)(V_{LL}) \quad (\text{STRENGTH I\_AASHTO 3.4.1})$$

$$= \boxed{14.20} \text{ kips}$$

$$\lambda_w = \frac{h}{tw} = \boxed{21.00}$$

$$\lambda_{c1} = 2.45 \left( \frac{E}{F_y} \right) = \boxed{69.537} > \lambda_w$$

$$\lambda_{c2} = 1.37 \left( \frac{kvE}{F_y} \right) = \boxed{194.419} > \lambda_w \quad kv \quad \boxed{5.00}$$

$$\lambda_{c3} = \dots = \boxed{260} > \lambda_w$$

**Shear Strength**

$$\phi V_n = \phi_v A_w 0.60 F_y C_v$$

where:

$$\phi = \boxed{0.90}$$

$$C_v = \boxed{1.00}$$

$$\phi V_n = \boxed{29.16} \text{ kips} > V_{Lx} = \boxed{14.20} \text{ kips} \quad (\text{OK!!!})$$

CASE 2 :

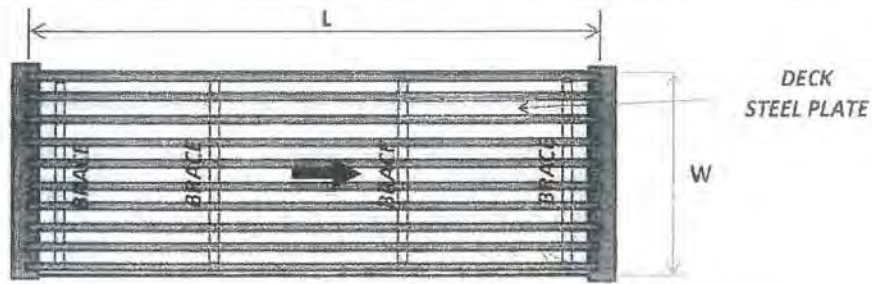

PLAN

Bridge Span	L	=	18.00	ft
Bridge Width	W	=	12.00	ft
Live Load Type		=	Special	

STRINGER

A. LOADINGS

Special Load	=	15.00	kips	As per Truck Specifications ( Truck Weight )
	=	17.00	kips	( Lowboy Trailer Weight )
	=	74.00	kips	( Load Carried by Truck_Crane Counterweight)
	$P_1$	=	15.00	kips ( Front Axle )
	$P_2$	=	45.50	kips ( Rear Axle )
	$P_3$	=	45.50	kips ( Rear Axle )
Axle Width	=	6.00	ft	
Wheelbase	v	=	14.00	ft

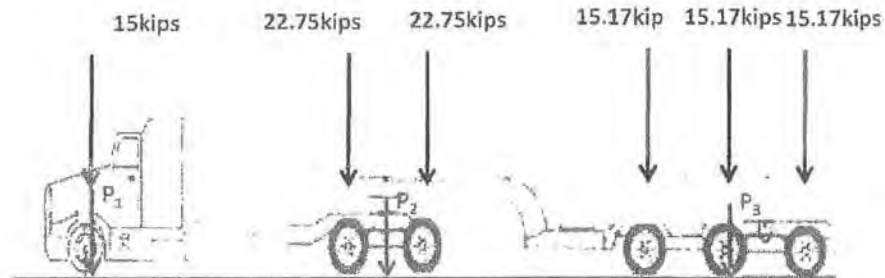

## B. DECK PLATE DESIGN

Deck Plate Properties:

Plate Thickness	t	=	0.75	in
Plate Width	v	=	20.00	in
Moment of Inertia	I	=	0.70	in <sup>4</sup>
Section Modulus	S	=	1.88	in <sup>3</sup>
Yield Strength	F <sub>y</sub>	=	36.00	ksi

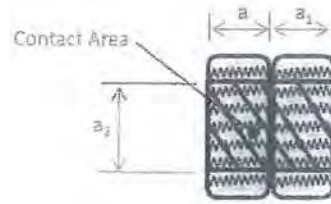

Truck Wheel

Wheel Contact Width	a <sub>1</sub>	=	10.0	in
Wheel Contact Length	a <sub>2</sub>	=	20.0	in

AASHTO 3.6.1.2.5

Dyn. Load Allowance	I.M.	=	0.33
---------------------	------	---	------

AASHTO 3.6.2

$$P_2/4 = 11.38 \text{ kips}$$

Deadload

Deck Plate Weight	w <sub>p</sub>	=	0.05	kips/ft
-------------------	----------------	---	------	---------

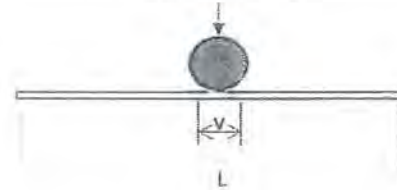

Livload ( per Axle )

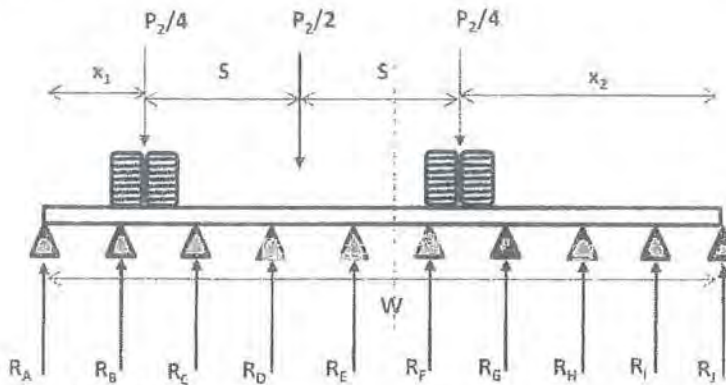

P <sub>2</sub>	=	45.50	kips
P <sub>2</sub> /4	=	11.38	kips

W	=	12.00	ft
S	=	3.00	ft
x <sub>1</sub>	=	0.67	ft
x <sub>2</sub>	=	5.33	ft

Reactions

R <sub>A</sub>	=	4.547	kips	R <sub>F</sub>	=	-0.128	kips	R <sub>TOT</sub>	=	R <sub>A</sub> + R <sub>B</sub> + ... + R <sub>J</sub>
R <sub>B</sub>	=	8.274	kips	R <sub>G</sub>	=	11.414	kips		=	22.8
R <sub>C</sub>	=	-1.823	kips	R <sub>H</sub>	=	-0.009	kips			
R <sub>D</sub>	=	0.000	kips	R <sub>I</sub>	=	0.002	kips			
R <sub>E</sub>	=	0.483	kips	R <sub>J</sub>	=	-0.001	kips			

Deadload Moment	M <sub>DL</sub>	=	0.01	kips-ft
-----------------	-----------------	---	------	---------

Livload Moment	M <sub>LL</sub>	=	3.03	kips-ft
----------------	-----------------	---	------	---------

Factored Moments :

$$M_u = 1.25M_{DL} + 1.75(1 + I.M.)(M_{LL}) = 7.07 \text{ kips-ft} \quad (\text{STRENGTH I\_AASHTO 3.4.1})$$

Moment Capacity

$$\phi M_n = \phi F_y Z_x = 7.59 \text{ kips-ft}$$

where :

φ	=	0.90	
F <sub>y</sub>	=	36.00	ksi
Z <sub>x</sub>	=	1.5 ( S <sub>x</sub> )	
	=	2.81	in <sup>3</sup>

$$M_u < \phi M_n \quad (\text{OK!!!})$$

### C. STRINGER DESIGN

Yield Strength	F <sub>y</sub>	=	36.00	ksi
Mod. of Elasticity	E	=	29000	ksi

#### Stringer Properties: Wide Flange

Depth	d	=	6.00	in
Flange Width	b <sub>f</sub>	=	6.00	in
Flange thickness	t <sub>f</sub>	=	0.25	in
Web thickness	t <sub>w</sub>	=	0.25	in
Area	A	=	4.38	in <sup>2</sup>
Moment of Inertia	I <sub>x</sub>	=	65.36	in <sup>4</sup>
	I <sub>y</sub>	=	265.01	in <sup>4</sup>
Radius of Gyration	r <sub>x</sub>	=	3.87	in
	r <sub>y</sub>	=	7.78	in

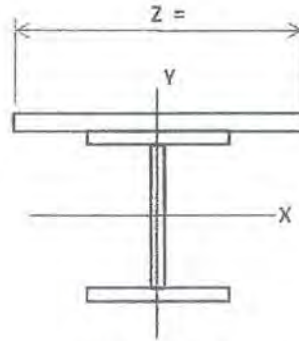

### LOADINGS

#### A. Deadload

Deck Plate Weight	w <sub>1</sub>	=	0.06	kips/ft/stringer
Stringer Weight	w <sub>2</sub>	=	0.01	kips/ft/stringer
	w <sub>TOT</sub>	=	0.08	kips/ft/stringer

#### B. Liveload

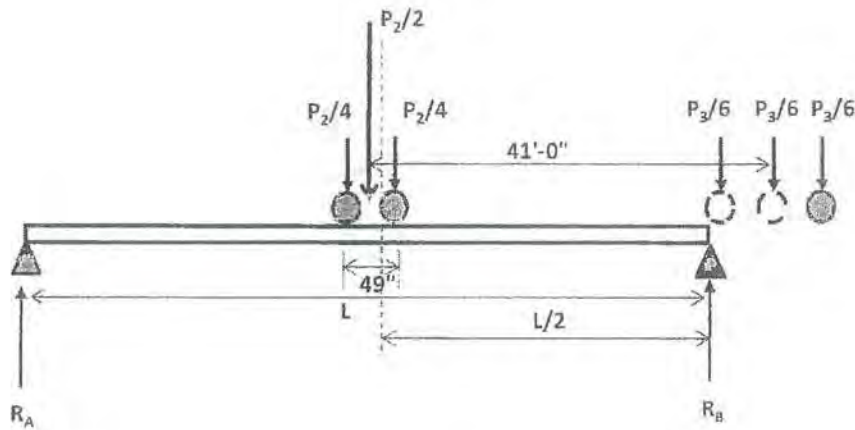

#### Reactions

R <sub>a</sub>	=	12.67	kips	P <sub>1</sub>	=	15.00	kips
R <sub>b</sub>	=	10.08	kips	P <sub>2</sub>	=	45.50	kips
				P <sub>3</sub>	=	45.50	kips

#### Maximum Moment:

Deadload Moment	M <sub>DL</sub>	=	3.08	kips-ft
Liveload Moment	M <sub>LL</sub>	=	75.20	kips-ft



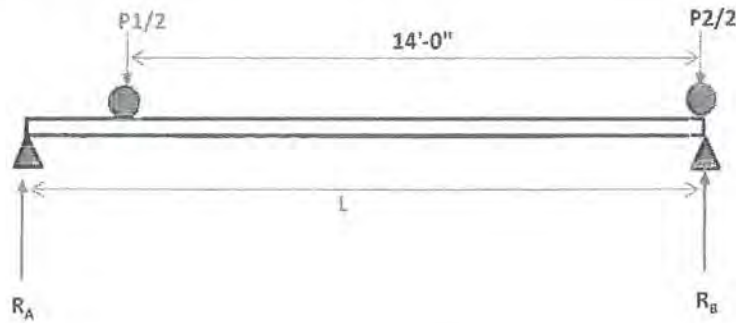

Reactions

$R_a = 5.83 \text{ kips}$        $R_b = 24.42 \text{ kips}$

Maximum Shear :

Deadload Shear       $V_{DL} = 0.69 \text{ kips}$   
 Liveload Shear       $V_{LL} = 24.42 \text{ kips}$

C. Seismic Load

AASHTO 3.10

Deck Weight	$W_d = 0.08 \text{ kip/ft}$
Stringer Weight	$W_s = 0.01 \text{ kip/ft}$
Total Dead Weight	$W_t = 0.10 \text{ kip/ft}$
Moment of Inertia	$I_x = 65.36 \text{ in}^3 \text{ (Strong Axis)}$
	$I_y = 265.01 \text{ in}^4 \text{ (Weak Axis)}$
Stringer Section Area	$A = 4.38 \text{ in}^2$
Mod. Of Elasticity	$E = 29000 \text{ ksi}$
Bridge Span	$L = 18.00 \text{ ft}$

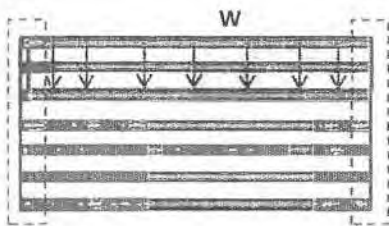

TRANSVERSE

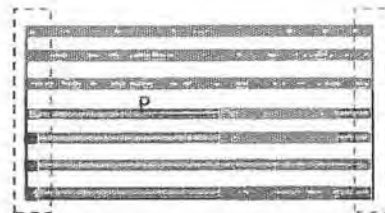

LONGITUDINAL

			TRANSVERSE	LONGITUDINAL	
Unit Deflection	$\delta$	=	$5WL^4 / 384EI$	$PL / AE$	
Stiffness	$k = (1 / \delta)$	=	0.0014	0.02043	ft/kip
Static Displacement	$V_s = (PL / k)$	=	702.81	48.95	kip/ft
Single Mode Factors	$\alpha = (V_s L)$	=	0.03	0.3677	ft
	$\beta = (\alpha Wt)$	=	0.46	6.6192	ft <sup>2</sup>
	$\gamma = (\beta V_s)$	=	0.04	0.64	ft - kip
Period of Oscillation	$T = (2\pi\gamma / P_g\alpha)$	=	0.00114	0.23502	ft <sup>2</sup> kip
Site Class	S	=	0.06	0.21	sec
	F <sub>pga</sub> (Site Class E)	=	E		
	F <sub>a</sub> (Site Class E)	=	1.08		
	F <sub>v</sub> (Site Class E)	=	0.90		
	S <sub>s</sub> (Guam)	=	2.40		
	S <sub>1</sub> (Guam)	=	1.50		
	PGA (Guam)	=	0.60		
	T <sub>M</sub> = T	=	0.34		
	A <sub>s</sub> = F <sub>pga</sub> x PGA	=	0.06	0.21	sec
	S <sub>DS</sub> = F <sub>a</sub> x S <sub>s</sub>	=	0.37		
	S <sub>D1</sub> = F <sub>v</sub> x S <sub>1</sub>	=	1.35		
	T <sub>0</sub> = 0.2 x S <sub>1</sub>	=	1.44		
	T <sub>s</sub> = S <sub>D1</sub> / S <sub>DS</sub>	=	0.12		sec
	C <sub>SM</sub> = A <sub>s</sub> + (S <sub>DS</sub> / A <sub>s</sub> ) / (T <sub>M</sub> / T <sub>0</sub> )	=	1.07		sec
	W = Wt x L	=	2.51	0.93	
	P <sub>T</sub> & P <sub>L</sub> = C <sub>SM</sub> x W	=	1.74		kip
		=	4.36	1.62	kip

### FACTORED MOMENTS

#### A. Strong Axis ( X - Axis )

$$M_{DL} = 3.08 \text{ kips-ft}$$

$$M_{LL} = \text{Truck + Crane Counterweight Load} = 75.20 \text{ kips-ft}$$

#### B. Weak Axis ( Y - Axis )

$$M_{EQ} = P_T \times L / 4 = 19.62 \text{ kips-ft}$$

#### With Seismic

$$M_{UX} = 1.25M_{DL} + 0.50(1+I.M.)(M_{LL}) \quad (\text{EXTREME EVENT I\_AASHTO 3.4.1})$$

$$= 53.86 \text{ kips-ft}$$

$$M_{UY} = 1.0 M_{EQ} = 19.62 \text{ kips-ft}$$

#### No Seismic :

$$M_{UX} = 1.25M_{DL} + 1.75(1+I.M.)(M_{LL}) \quad (\text{STRENGTH I\_AASHTO 3.4.1})$$

$$= 53.86 \text{ kips-ft}$$

**FLEXURE CHECK ( BIAXIAL ) :**

**Flexural Strength**

Check Length:

$$L_b = \frac{L}{4} = \frac{4.50}{1} \text{ ft}$$

$$L_p = 1.76 r_y (E/F_y)^{0.50} = 32.40 \text{ ft}$$

Check Compactness:

$$\lambda_f = \frac{bf}{2tf} = 2.400$$

$$\lambda_{pf} = 0.38 \left( \frac{E}{F_y} \right)^{0.5} = 10.785$$

Since :

$$L_b < L_p$$

$$\lambda_f < \lambda_{pf}$$

Then :

$$\phi M_{nx} = \phi F_y Z_x = 45.08 \text{ kips-ft}$$

where

$$\phi = 0.90$$

$$Z_x = 16.69 \text{ in}^3$$

**Section Check**

With Seismic :

$$\frac{M_{ux}}{\phi M_{nx}} + \frac{M_{uy}}{\phi M_{ny}} \leq 1.0$$

where

$$Z_y = 52.59 \text{ in}^3$$

$$\phi M_{ny} = \phi F_y Z_y = 141.98 \text{ kip-ft}$$

$$\frac{53.86}{45.08} + \frac{19.62}{141.98} = 1.33 \text{ (NOT OK!!!)}$$

No Seismic :

$$M_{ux} > \phi M_{nx} \text{ (NOT OK!!!)}$$

**AXIAL & FLEXURE CHECK :**

$$kL/r = 27.753$$

$$4.71 (E/F_y)^{0.5} = 133.681$$

$$F_e = \frac{\pi^2 E}{(kL/r)^2} = 371.59 \text{ ksi}$$

$$kL/r < 4.71 (E/F_y)^{0.5}$$

$$F_e > 0.44 F_y$$

Therefore :

$$F_{cr} = [0.658^{(F_y/F_e)}] F_y = 34.569 \text{ ksi}$$

$$P_n = F_{cr} A_g = 151.241 \text{ kips}$$

$$\left( \frac{P_L}{2\phi P_n} \right) + \left( \frac{M_{ux}}{\phi M_{nx}} \right) \leq 1.0$$

$$\left( \frac{1.62}{272.23} \right) + \left( \frac{53.86}{45.08} \right) = 1.20 \quad (\text{NOT OK!!!})$$

SHEAR CHECK :

Factored Shear

$$V_{DL} = 0.69 \text{ kips}$$

$$V_{LL} = 24.42 \text{ kips}$$

$$V_{UX} = 1.25V_{DL} + 1.75(1+I.M.)(V_{LL}) \quad (\text{STRENGTH I\_AASHTO 3.4.1})$$

$$= 17.09 \text{ kips}$$

$$r_w = \frac{h}{t_w} = 22.00$$

$$r_{t1} = 2.45 \left( \frac{E}{F_y} \right) = 69,537 > r_w$$

$$r_{t2} = 1.37 \left( \frac{k_v E}{F_y} \right)^{0.5} = 194,419 > r_{t1} \quad k_v = 5.00$$

$$r_{ts} = \dots = 260 > r_{t2}$$

Shear Strength

$$\phi V_n = \phi_v A_w 0.60 F_y C_v$$

where

$$\phi = 0.90$$

$$C_v = 1.00$$

$$\phi V_n = 29.16 \text{ kips} > V_{UX} = 17.09 \text{ kips} \quad (\text{OK!!!})$$



d

# Exhibit d

# **Korando Correspondence**

Dated July 01, 2015

Re: Bile/Pigua Bridge Project GU-NH-NBIS(007)  
Notice of Default-Response



**KORANDO CORPORATION**  
GENERAL CONTRACTOR

P.O. BOX 20538  
GMF, GUAM 96921  
TEL: (671) 649-7880  
(671) 649-7881  
FAX: (671) 649-7882  
EMAIL: admin\_korando@teleguam.net

*dm H G rest*

July 1, 2015,

Department of Public Works  
542 N. Marine Drive Corps.  
Tamuning, Guam 96913  
Attn: Director- Glenn Leon Guerrero

Re: Bile/Pigua Bridge Replacement Project  
GU-NH-NBIS (007)  
NOTICE of DEFAULT - RESPONSE

**COPY**



Dear Mr. Glenn Leon Guerrero,

We are in receipt of the DPW letter dated June 26, 2015 received by Korando Corporation on June 29, 2015. Subject regarding Notice of Default. Please be informed that Korando Corporation has been working with the Bile-Pigua Project on a consistent basis. For all subsections listed on the DPW letter dated June 26, 2015 we do have responses to these items. Please see below referencing for each issue that has been brought up by DPW.

1. **Section 108.1 Commencement, Prosecution and Completion of Work**  
*NTP was provided by DPW to commence work on January 5, 2015, Korando Corporation is unable to do any physical work at the jobsite unless all provisions of the Permit were in compliance. The final agencies (Guam EPA, Dept. of Agriculture and GWA, and GPA) completed and approved provision on February 26, 2015. This placed Korando Corporation 52 calendar days behind schedule. (Pls. refer to attachment A)*
2. **Section 108.5 (e)**  
*Korando Corporation has not refused or failed to prosecute work for the above stated project. We are diligently working to provide both DPW and Stanley Consultants continued progress on this project.*
3. **Section 108.5 (f)**  
*Korando Corporation has not refused or failed to regard the laws, ordinances or the instructions of the Contracting Officer.*
4. **Section 155.06 – Schedule Updates**  
*Korando Corporation has diligently provided Schedule Updates to Stanley Consultants at their meetings providing information as needed by the consultants.*
5. **Formal Contract Article 1(a) Contract Time**  
*Formal Contract attached with this letter. Korando Corporation is working to complete this project on time. Completion time has not lapsed we are doing our best to move forward to complete this project on time. We are aware that we are currently 59 days delayed realistically*

KORANDO CORPORATION

but we are pushing forward to meet the completion time. (Pls. refer to Attachment D for "Formal Contract")

**6. Instructions to Bidders Article 11. Time of Completion**

*Korando Corporation acknowledges that we on our own accord and cost, hired our own designer to reanalyze the structure of the existing bridge. Wherein which we submitted an RFI #11 inquiring the use of an Alternate Phasing plan. Again, as stated in our letter dated May 27, 2015 to DPW, our main concern for the alternate phasing is the efficiency of the bridge transportation and the safety of the public. (Pls. refer to Attachment F)*

**7. Notice to Bidders Article 5. Contract Time**

*Formal Contract attached with this letter. Korando Corporation is working to complete this project on time. Completion time has not lapsed we are doing our best to move forward to complete this project on time. We are aware that we are currently 59 days delayed realistically but we are pushing forward to meet the completion time.*

**8. FP-03 Subsection 107.01 Laws to be Observed**

*Korando Corporation is in compliance with the laws, the ordinances, the safety codes, regulations, orders and decrees. Korando Corporation is observant to the Laws of Guam.*

**9. FP-03 Subsection 155.01 / FAR Sections 52.236-15 Schedules for Construction Contracts**

*Korando Corporation has diligently provided Schedule Updates to Stanley at their meetings providing information as needed by the consultants.*

**10. FAR and 52.249-10 Default (Fixed Price Construction)**

*Korando Corporation has not refused or failed to prosecute any work with regards to the completion of this project. Though Korando Corporation acknowledges that there may be a delay, we continue to strive towards the goal of the completion time. We will not surrender any time and effort that can be placed into this project to move forward.*

**11. Article 1.3 of the Required Contract Provisions (RCP) Federal-Aid Construction Contract**

*Korando Corporation has not breached any stipulations contained in this Required Contract Provisions (RCP) Federal-Aid Construction Contract intentionally or knowingly.*

**12. Instruction to Bidders Article 25 Termination of Work on Failure to Pay Agreed Wages.**

*We are in accordance to the prevailing wages of Guam Department of Labor. We pay our workers based on the Minimum Wage Rate provided by DPW Bid Documents General Decision No. GU20120001. Korando Corporation has not failed to pay any of its employees what is in accordance to the law. (Pls. refer to Attachment B)*

Many of the breach of contract provisions listed are majority documentation reporting. We now understand that there are protocols on submissions of reports that were not followed accordingly (until it was brought to our attention) but we have taken care of these issues and are up to date with our reporting.

KORANDO CORPORATION



With regards to the NTP and the days of completion we are standing firm that we continue to move our work ahead and focus on this completion date of 450 days. Our realistic schedule attached with this letter shows a delay of 59 days we are still moving forward to lessen the amount of days delayed as time progresses. *(Pls. refer to Attachment D)*

We understand that DPW will not respond to our letter dated June 22, 2015 with Subject Major Changes to the Electrical Plan unless we:

- a) commence meaningful work on the project
- b) supply enough properly skilled workmen and provide the materials to complete the work within the contract term
- c) to submit acceptable updated project schedule *(Pls. refer Attachment E)*
- d) other listed defects

*Please refer to Attachment C which lists the commencement of meaningful work for each item a-d above.*

We would like to inform DPW that all materials for this project is awaiting the Electrical plan approval. In other words, the Electrical Plan is a Pivotal Focus in this project. As soon as the Electrical Plan is approved, Korando Corporation will be able to make extensive progress to this project. We project an added 40% work completion within the next 2 months upon approval of the electrical plan.

With these issues at hand we would like to request a meeting with all relevant personnel involved with the Bile-Pigua Bridge Replacement Project.

Sincerely,



Byong-Ho Kim  
President

Cc: Isidro Duarosan, DPW  
Crispin Bensen, DPW  
Richelle Takara, FHWA  
Jack Marlowe, CM  
Joseph Pecht, PTG  
Derrick Lehman, PTG  
Houston Anderson, PTG  
Westchester Fire Insurance Company c/o Takagi &, Inc.

KORANDO CORPORATION

# ATTACHMENT A

Government Agencies Permits Requirement to Comply  
- Prior to any Site Work may Proceed

<u>Submittals</u>	<u>Date Submitted/Re-Submitted</u>	<u>Date Response</u>
NTP	- January 5, 2015 -	January 8, 2015
Encroachment Permit	- January 7, 2015 -	January 8, 2015
HACCP (Dept. of Agriculture)	- February 18, 2015 -	March 4, 2015
GEPA Disposal Plan	- February 5, 2015 -	February 18, 2015
GEPA Water Qual. Mon. Plan	- February 18, 2015 -	February 26, 2015
EPP & ECP	- February 4, 2015 -	February 26, 2015
DOA & GWA Site Consultation/Orientation (Done March 5, 2015)	March 30, 2015 -	April 15, 2015

**Transmittal/Review/Approval**

FILE NAME: Notice To Permit and Encroachment Permit

DATE: 01/07/2015

CONTRACT NO.: GU-NH-NBIS(007)	TITLE: (Fill in Project Title/Location Here) Bile / Pigua Bridge Replacement (Construction Phase), Route 4, Merizo, Guam		
FROM (CONTRACTOR): Korando Corporation	TO: Jack Marlowe / Chief Project Rep.	SUBMITTAL NO.: 108.001-01	SPECS. SECTION: SCR 108

ENCL. NO.	NO. OF COPIES	DESCRIPTION	SPEC.SEC./PARA	SCHEDULE ACTIVITY NO.	CQC CODE
		Bile & Pigua Bridge Replacement (Construction Phase)			
1	6	Notice To Permit (NTP) and Encroachment Permit	SCR 108-01	A1000 / A1090	A

DATE NEEDED BY:

TRANSMITTED FOR:  APPROVAL  CLARIFICATION  SELECTION  RECORD  VARIANCE

<i>It is hereby certified that the material submitted herein conforms to contract requirements and can be installed in the allocated spaces.</i>	CONTRACTOR'S REPRESENTATIVE NAME/TITLE Ruel Remetira / Korando	SIGNATURE: 
--	---	--

Received By (Print Name & Sign)/Date/Time: Jack Marlowe / Stanley 01/07/2014

FROM:	SIGNATURE:	DATE:
-------	------------	-------

TO: Jack Marlowe / Stanley Consultants	<i>For review/comment ( ) copies of enclosures forwarded. RETURN WITHIN ( ) WORKING DAYS, unless submittal is for record/info purposes only and there are no adverse comments.</i>
---	--

Received By (Print Name & Sign)/Date/Time: Jack Marlowe / Stanley 01/07/2014

FROM:	TO:	DATE:
-------	-----	-------

RECOMMEND / Enclosure(s) is (are):

<input type="checkbox"/> No Exception Taken (NET)	<input type="checkbox"/> Rejected/Resubmit (Rej/R)	<input type="checkbox"/> _____
<input type="checkbox"/> Exceptions As Noted (EAN)	<input type="checkbox"/> No Action Required (NAR)	<input type="checkbox"/> _____
<input type="checkbox"/> Revise/Resubmit (Rev/R)	<input type="checkbox"/> Not Subject To Review (NSTR)	

REMARKS:

Copies of encls returned: \_\_\_\_\_ SIGNATURE: \_\_\_\_\_

Copy to: \_\_\_\_\_

Received By (Print Name & Sign)/Date/Time: \_\_\_\_\_





The Honorable  
**Eddie Baza Calvo**  
Governor

The Honorable  
**Ray Tenorio**  
Lieutenant Governor



December 29, 2014

Mr. Byong Ho Kim  
President  
Korando Corporation  
380H Harmon Industrial Park  
Tamuning, Guam 96913

Re: **Bile / Pigua Bridges Replacement**  
**Project No. GU-NH-NBIS(007)**  
**NOTICE TO PROCEED**

Dear Mr. Kim,

You are hereby notified to commence work on the above referenced project on **Monday, January 5, 2015** which shall be day number one (1) of the working days stipulated in the Contract. All work, including final cleanup shall be completed within **450** calendar days. Failure to complete the entire project within the **500** calendar days stipulated in the contract will result in Liquidated Damages being assessed in the amount of **\$2,200.00** per calendar day.

All changes, deviations from, or clarifications to the plans and specifications will be valid only if directed, in writing, by the Department of Public Works Contracting Officer. All inspections, acceptance testing and other requirements shall be coordinated with the Department of Public Works.

**Please include the above Project Name and Project Number on all project correspondence.**

Should you have any questions or need additional information, please contact Mr. Jack Marlow, Chief Resident Project Representative with Stanley Consultants at 646-3466, Mr. Crispin Bensen, Project Engineer, DPW or Mr. Mike Lanning, Guam Program Manager with Parsons Transportation Group at 648-1060.

Acknowledge receipt of this notice on the space provided below and return a copy to the Department of Public Works, Division of Highways to the attention of Mr. Isidro Duarosan, Engineer Supervisor.

Sincerely,



CARL V. DOMINGUEZ



IDuarosan/PSiegel/TBlaz

Cc: Jack Marlow, Stanley  
Crispin Bousan, DPW  
Mike Lanning, PTG  
Richelle Takara, FHWA

RECEIPT OF THE ABOVE NOTICE TO PROCEED IS HEREBY ACKNOWLEDGED

THIS 2nd DAY OF JANUARY 2011, 5

By: BYONG HO KIM - PRESIDENT  
(Print Name & Title)

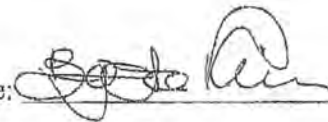
Signature: 





ACKNOWLEDGEMENT OF RECEIPT

- TRAFFIC CONTROL PLAN
- ROAD RESTORATION DETAILS
- INITIAL and FINAL INSPECTION REQUEST FORM

Print Name: \_\_\_\_\_  
Signature: \_\_\_\_\_  
Date: \_\_\_\_\_

# HIGHWAY ENCROACHMENT PERMIT

Permit Number : 15-045

Issue Date : 11-05-2014

Type of Permit :

- |  |   |   |
|--|---|---|
| <input type="checkbox"/> Communication | <input type="checkbox"/> Lane Closure     | <input type="checkbox"/> Testing  |
| <input type="checkbox"/> Driveway      | <input type="checkbox"/> Power            | <input type="checkbox"/> Trenching  |
| <input type="checkbox"/> Hauling       | <input type="checkbox"/> Sewer Connection | <input type="checkbox"/> Waterline Connection   |
| <input type="checkbox"/> Improvement   | <input type="checkbox"/> Sign             | <input checked="" type="checkbox"/> Other <u>Reconstruction of</u><br><u>Pike &amp; Piquet Bridge</u> |

Issued To :

Korondo Corporation

Beginning Date : 11-05-2014

Completion Date : July 2016

Location :

Older KANTON TRS NAKIB

Purpose :

Reconstruction of Pike & Piquet Bridge

- Use of this permit shall be restricted to the purpose stated above. Encroachment permits are not transferable.
- No hauling or closing of traffic lanes during rush hours (7:00 a.m. to 9:00 a.m., 12:00 p.m. to 1:00 p.m., and 4:00 p.m. to 6:00 p.m.), except on weekends and legal holidays.
- Open trench shall be covered with steel plate 1" thick overlaps welded and all other sides with AC cold mix.
- Temporary restoration for trenched roadways or highways shall be done with cold mixed asphalt materials.
- Encroachment Permit shall be at the project site at all times during the working hours. Failure to present valid permit may result in the suspension of the work.
- Encroachment Permits are revocable upon five (5) days notice by the Department of Public Works, if any provision under which the permit has been issued is violated by the applicant, contractor or authorized representative.
- Traffic Cones and Signs for lane closures & traffic control must be provided by the applicant or contractor and must be of reflective material/color for night time or use of permit.

*Handwritten initials/signature*

Printed Name & Signature of Authorized DPW Representative





## APPLICATION FOR HIGHWAY ENCROACHMENT

*HOP-15-045*

Type of Encroachment (please check one)

- |  |   |   |
|--|---|---|
| <input type="checkbox"/> Communication | <input type="checkbox"/> Lane Closure     | <input type="checkbox"/> Testing  |
| <input type="checkbox"/> Driveway      | <input type="checkbox"/> Power            | <input type="checkbox"/> Trenching  |
| <input type="checkbox"/> Hauling       | <input type="checkbox"/> Sewer Connection | <input type="checkbox"/> Waterline Connection                             |
| <input type="checkbox"/> Improvement   | <input type="checkbox"/> Sign             | <input checked="" type="checkbox"/> Other <b>PILE &amp; PIOLA BRIDGES</b> |

**Applicant Information** (please ensure that all information is provided)

Name of Applicant: <b>KORANDO CORPORATION / DONG HO KIM</b>		Social Security Number: <b>RECONSTRUCTION</b>
Home Phone:	Work Phone: <b>649-7880</b>	Other Contact Number: <b>649-7881</b>
Mailing Address: <b>P.O. BOX 20538 G.M.F., BARRIGADA, GUAM</b>		
Residential Address: <b># 38 HARMON INDUSTRIAL PARK, HARMON, NYMON, GUAM</b>		

**Contractor Information** (please ensure that all information is provided)

Name of Company: <b>KORANDO CORPORATION</b>	Employer Identification No.:	Telephone Nos. <b>649-7880</b>	Fax No. <b>649-7881</b>
Contact Person: <b>JONI PALMA</b>		Cell Phone No. <b>898-9290</b>	Other Contact No.:
Mailing Address: <b>P.O. BOX 20538 G.M.F. BARRIGADA, GUAM</b>			
Office Location: <b># 38 HARMON INDUSTRIAL PARK, HARMON, NYMON, GUAM</b>			

Contractor shall notify the Department of Public Works two (2) days before commencing any work and arrange for all necessary inspections.

**Project Description & Location** (describe in detail the work to be performed or purpose of permit)

Type of work to be performed or purpose of permit: <b>RECONSTRUCTION REPAIRMENT OF PILE &amp; PIOLA BRIDGES</b>	
Location (Street Name & Village): <b>CHAMAN KANTON DAS, MERIZO</b>	
Estimated Starting Date: <b>ASAP</b>	Estimated Completion Date: <b>JULY 2016</b>

\_\_\_\_\_  
Signature of Applicant

**11-5-19**  
\_\_\_\_\_  
Date

\_\_\_\_\_  
Signature of Contractor

**11-5-19**  
\_\_\_\_\_  
Date



Permission is hereby given to do the work described in this application according to the conditions hereon and according to the approved plans and specifications pertaining thereto, subject to compliance with Chapter 70 of the Uniformed Building Codes. No burning on site is allowed, unless a burning permit has been issued by the Guam Fire Department.

- Remarks:
1. ADVERTISE TO PDN.
  2. PROVIDE APPROVED TEMPORARY TRAFFIC CONTROL PLAN (TTCP) PRIOR TO CONSTRUCTION.

\_\_\_\_\_  
Mayor's Signature

\_\_\_\_\_  
Date

Department of Public Works Approval:

\_\_\_\_\_  
Signature

\_\_\_\_\_  
Date

Permit Number: 15-045	Fee: \$25.00	Receipt Number:
	Bond: PERFORMANCE BOND	Receipt Number:

INSPECTOR'S CLEARANCE

I hereby certify that all work, as requested in this application, has been completed in conformity with Public Law 10-40 and the Uniformed Building Codes, and in accordance with the approved plans and specification.

Date of Inspection	Name of Inspector	Inspector's Signature
_____	_____	_____



**GOVERNMENT OF GUAM  
INTRA-OFFICE MEMORANDUM**

HEP-15-045

TO: Treasurer of Guam

Date: 11-05-14

Payor: Korando Corporation

Description	Account Name	Account No.	Amount
Highway Encroachment Permit Fee Political Sign Fees	Care & Protection of Highways	310056204	\$25.00
Paid Notice of Violation Fee	Notice of Violation Penalty Fee	320861001	}
Deposit Fee and Bond Per Public Law 31-83	Condition for Deposit Fees & Bond	120823110	
Political Sign Deposit Bond	Political Sign Bond	110023155	
	Savings -THF	120810220	
Contractor Deposit Fees Prior to Public Law 31-83 (Oct. 31,2011)	PW Performance Bond	110023110	
<b>TOTAL</b>			<b>\$25.00</b>

Purpose: Reconstruction of Bile & Pigna Bridge

Signature of Authorize Agent/Issuing Office

**RECEIVED**  
NOV 05 2014  
TREASURER OF GUAM  
ONE STOP OFFICE  
INITIAL: JS



<b>Transmittal/Review/Approval</b>		FILE NAME: Hazard Analysis Critical Control Points (HACCP) Plan	DATE: 2/18/2015																				
CONTRACT NO.: GU-NH-NBIS(007)		TITLE: (Fill in Project Title/Location Here) Bile / Pigua Bridge Replacement (Construction Phase), Route 4, Merizo, Guam																					
FROM (CONTRACTOR): Korando Corporation		TO: Jack Marlowe / Chief Project Rep.	SUBMITTAL NO.: <del>107.005-02</del> <b>107.007-01</b>																				
			SPECS. SECTION: 107																				
ENCL. NO.	NO. OF COPIES	DESCRIPTION	SPEC.SEC./PARA	SCHEDULE ACTIVITY NO.	CQC CODE																		
		Bile & Pigua Bridge Replacement (Construction Phase)																					
1	36	Hazard Analysis Critical Control Points (HACCP) Plan (Department of Agriculture (DOA) - NET)	SCR 107.10.e.1	A1110	A																		
DATE NEEDED BY:																							
TRANSMITTED FOR: <input checked="" type="checkbox"/> APPROVAL <input type="checkbox"/> CLARIFICATION <input type="checkbox"/> SELECTION <input type="checkbox"/> RECORD <input type="checkbox"/> VARIANCE																							
It is hereby certified that the material submitted herein conforms to contract requirements and can be installed in the allocated spaces.		CONTRACTOR'S REPRESENTATIVE NAME/TITLE Ricarte Bisquera / Korando	SIGNATURE: 																				
Received By (Print Name & Sign)/Date/Time:    Jack Marlowe / Stanley    2/18/2015																							
FROM:		SIGNATURE:		DATE:																			
TO: Jack Marlowe / Stanley Consultants		For review/comment ( ) copies of enclosures forwarded. RETURN WITHIN ( ) WORKING DAYS, unless submittal is for record/info purposes only and there are no adverse comments.																					
Received By (Print Name & Sign)/Date/Time:    Jack Marlowe / Stanley    2/18/2015																							
FROM:		TO:		DATE:																			
RECOMMEND / Enclosure(s) is (are):																							
<input type="checkbox"/> No Exception Taken (NET)		<input type="checkbox"/> Rejected/Resubmit (Rej/R)		<input type="checkbox"/> _____																			
<input type="checkbox"/> Exceptions As Noted (EAN)		<input type="checkbox"/> No Action Required (NAR)		<input type="checkbox"/> _____																			
<input type="checkbox"/> Revise/Resubmit (Rev/R)		<input type="checkbox"/> Not Subject To Review (NSTR)																					
REMARKS:																							
<input type="checkbox"/> Copies of encls returned:		<table border="1" style="width:100%; border-collapse: collapse;"> <tr> <td>A. No Exceptions Taken</td> <td><input checked="" type="checkbox"/></td> <td>Job: GU-NH-NBIS(007)</td> </tr> <tr> <td>B. Exceptions As Noted</td> <td><input type="checkbox"/></td> <td>Submittal No. <u>107.007-01</u></td> </tr> <tr> <td>C. Revise / Resubmit</td> <td><input type="checkbox"/></td> <td>By <u>Jack Marlowe</u></td> </tr> <tr> <td>D. Rejected / Resubmit</td> <td><input type="checkbox"/></td> <td>Date: <u>3/4/15</u></td> </tr> <tr> <td>E. No Action Required</td> <td><input type="checkbox"/></td> <td></td> </tr> <tr> <td>F. Not Subject to Review</td> <td><input type="checkbox"/></td> <td></td> </tr> </table>				A. No Exceptions Taken	<input checked="" type="checkbox"/>	Job: GU-NH-NBIS(007)	B. Exceptions As Noted	<input type="checkbox"/>	Submittal No. <u>107.007-01</u>	C. Revise / Resubmit	<input type="checkbox"/>	By <u>Jack Marlowe</u>	D. Rejected / Resubmit	<input type="checkbox"/>	Date: <u>3/4/15</u>	E. No Action Required	<input type="checkbox"/>		F. Not Subject to Review	<input type="checkbox"/>	
A. No Exceptions Taken	<input checked="" type="checkbox"/>	Job: GU-NH-NBIS(007)																					
B. Exceptions As Noted	<input type="checkbox"/>	Submittal No. <u>107.007-01</u>																					
C. Revise / Resubmit	<input type="checkbox"/>	By <u>Jack Marlowe</u>																					
D. Rejected / Resubmit	<input type="checkbox"/>	Date: <u>3/4/15</u>																					
E. No Action Required	<input type="checkbox"/>																						
F. Not Subject to Review	<input type="checkbox"/>																						
Action taken hereon does not supersede requirements of applicable design drawings, specifications, orders, codes or regulations or relieve the contractor or supplier from responsibility for errors or omissions.																							
GUAM:DPW																							
Received By (Print Name & Sign)/Date/Time:    _____    _____    _____																							
CHIEF ENGINEER    DATE																							





<b>Transmittal/Review/Approval</b>		FILE NAME: GEPA Water Quality Monitoring Plan (WQMP)	DATE: 2/18/2015
CONTRACT NO.: GU-NH-NBIS(007)		TITLE: (Fill in Project Title/Location Here) Bile / Pigua Bridge Replacement (Construction Phase), Route 4, Merizo, Guam	
FROM (CONTRACTOR): Korando Corporation		TO: Jack Marlowe / Chief Project Rep.	SUBMITTAL NO.: <del>107-003-03</del> 107.002-02 SPECS. SECTION: 107

ENCL. NO.	NO. OF COPIES	DESCRIPTION	SPEC.SEC./PARA	SCHEDULE ACTIVITY NO.	CQC CODE
		Bile & Pigua Bridge Replacement (Construction Phase)			
1	11	GEPA Section 401A Water Quality Monitoring Plan - Resubmittal	107.10	A1100	A

DATE NEEDED BY:

TRANSMITTED FOR:     APPROVAL     CLARIFICATION     SELECTION     RECORD     VARIANCE

*It is hereby certified that the material submitted herein conforms to contract requirements and can be installed in the allocated spaces.*

CONTRACTOR'S REPRESENTATIVE NAME/TITLE Ruel Remetira / Korando	SIGNATURE: 
---	----------------

Received By (Print Name & Sign)/Date/Time:    Jack Marlowe / Stanley    2/18/2015

FROM:	SIGNATURE:	DATE:
TO: Jack Marlowe / Stanley Consultants	For review/comment ( ) copies of enclosures forwarded. RETURN WITHIN ( ) WORKING DAYS, unless submittal is for record/info purposes only and there are no adverse comments.	

Received By (Print Name & Sign)/Date/Time:    Jack Marlowe / Stanley    2/18/2015

FROM:	TO:	DATE:

RECOMMEND / Enclosure(s) is (are):

<input type="checkbox"/> No Exception Taken (NET)	<input type="checkbox"/> Rejected/Resubmit (Rej/R)	<input type="checkbox"/> _____
<input type="checkbox"/> Exceptions As Noted (EAN)	<input type="checkbox"/> No Action Required (NAR)	<input type="checkbox"/> _____
<input type="checkbox"/> Revise/Resubmit (Rev/R)	<input type="checkbox"/> Not Subject To Review (NSTR)	

REMARKS:

<input checked="" type="checkbox"/> A. No Exceptions Taken <input checked="" type="checkbox"/> B. Exceptions As Noted <input type="checkbox"/> C. Revise/Resubmit <input type="checkbox"/> D. Rejected/Resubmit <input type="checkbox"/> E. No Action Required <input type="checkbox"/> F. Not Subject to Review	Job: GU-NH-NBIS(007) Submittal No. 107.002-02 By: Date: 2/18/15
---	--

Copies of encls returned:

Copy to:

GUAM DPW	DATE
----------	------

Received By (Print Name & Sign)/DATE/TIME: \_\_\_\_\_



# GUAM ENVIRONMENTAL PROTECTION AGENCY

AHENSIAN PRUTEKSION LIN'ALA GUAHAN

EDDIE BAZA CALVO  
GOVERNOR OF GUAM

RAY TENORIO  
LT. GOVERNOR OF GUAM

ERIC M. PALACIOS  
ADMINISTRATOR

YVETTE CRUZ  
DEPUTY ADMINISTRATOR

P.O. BOX 22439 BARRIGADA, GU 96921

EPA.GUAM.GOV

FEB 16 2015

Mr. Ruel Remetira  
Project Manager  
Korando Corporation  
P.O. Box 20538  
GMF, Guam 96921

Re: Revised Water Quality Monitoring Plan for the Replacement  
(Construction Phase) of Bile/Pigua Bridge, Route 4, Merizo, Guam.  
Contract No. GU-NH-NBIS(007)

Hafa Adai Mr. Remetira,

The technical staff of the Guam Environmental Protection Agency (GEPA) has completed the review of the submitted Revised Water Quality Monitoring Plan for above referenced project, and hereby approves and all the provisions thereof are strictly implemented.

Should there be any unexpected environmental problems that may arise from the project, immediate corrective measures shall be implemented and reported to this Agency for evaluation. The point of contact for the above subject project is the undersigned and/or Mr. Ray Calvo at (671) 300-4784 or email Ray.Calvo@epa.guam.gov.

**Failure to comply with the above conditions and/or any provisions of the approved Water Quality Monitoring Plan prompted this Agency in the issuance of a Stop Work Order or Notice of Violation.** Please be advised that a Stop Work Order or a Notice of Violation in no way precludes the use of other enforcement actions available to this Agency including the pursuit of criminal charges and/or penalties applicable to any or other subsequent violations.

Si Yu'us Ma'ase,

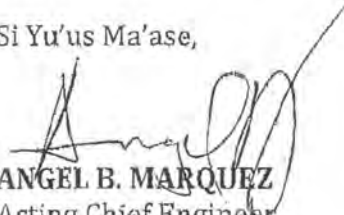
  
ANGEL B. MARQUEZ  
Acting Chief Engineer

RECEIVED  
FEB 16 2015

Guam Environmental  
Protection Agency





**KORANDO CORPORATION**

P.O. BOX 20538, GMF, GUAM 96921

TEL. NOS. (671) 649-7880/01

FAX NO. (671) 649-7882

**WATER QUALITY MONITORING  
(WQM) REVISED PLAN  
(Feb. 13, 2015)**

**For**

Contract: GU-NH-NBIS(007)  
BILE / PIGUA BRIDGE  
REPLACEMENT (CONSTRUCTION)  
ALONG ROUTE 4 ROAD, MERIZO, GUAM

**Submitted to:**

Division of Highways  
Department of Public Works  
Government of Guam

**Submitted by:**

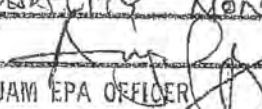
<b>GUAM ENVIRONMENTAL PROTECTION AGENCY</b>	
WATER POLLUTION CONTROL PROGRAM	
PERMIT NO. <u>M-0697</u>	DATE: <u>2-16-15</u>
<input checked="" type="checkbox"/> APPROVED	<input type="checkbox"/> CONDITIONALLY APPROVED
REMARKS: <u>REVISED WATER</u>	
<u>QUALITY MONITORING PLAN</u>	
BY: 	
GUAM EPA OFFICER	

KORANDO CORPORATION  
P.O. Box 20538  
GMF, Guam 96921

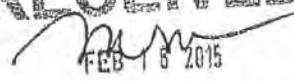
**RECEIVED**  
  
FEB 16 2015

Guam Environmental  
Protection Agency

## TABLE OF CONTENTS

1.0	PROJECT / SITE INFORMATION	
1.1	Responsible Parties	2
2.0	INTRODUCTION	2
2.1	Purpose	2
2.2	General Site and Project Information	2
2.3	Applicable Water Quality Standards	4
2.4	Measures to Protect These Features	4
2.5	Storm Sewer System	4
3.0	POTENTIAL SOURCES OF POLLUTION	
3.1	Potential Sediment Sources	4
3.2	Other Sources	5
4.0	MONITORING ACTIVITIES	
4.1	Frequency	4
4.1.a	Turbidity	4
4.1.b	pH	4
4.1.c	Monitoring Equipment	5
4.1.d	Sampling Method and Procedure	5
4.1.e	Depth and Location	5
4.1.f	Qualification	5
4.1.e	Reporting	6
4.2	Corrective Action	6
5.0	ATTACHMENTS	
5.1	Bile Bridge Replacement Project Area	7
5.2	Pigua Bridge Replacement Project Area	8
5.3	Erosion & Sedimentation Control Inspection Form	9



## 1.0 PROJECT/SITE INFORMATION

Project/Site Name: Bile / Pigua Bridge Replacement (Construction Phase)  
Project Location: Along Route 4, Merizo, Guam  
Latitude/Longitude: Bile - 13° 16' 37.60" N / 144° 39' 51.77" E  
Pigua - 13° 16' 30.60" N / 144° 39' 50.95" E

### 1.1 Responsible Parties:

Francisco "Joni" Palma, Jr.  
Area Manager  
Korando Corporation  
P.O. Box 20538  
G.M.F., Guam 96921  
Tel. No. (671) 649-7880 / 81

Hyon Kim Sang  
Operation Manager  
Korando Corporation  
P.O. Box 20538  
G.M.F., Guam 96921  
Tel. No. (671) 633-7261

Ruel Remetira  
Project/Site Manager  
Korando Corporation  
P.O. Box 20538  
G.M.F., Guam 96921  
Tel. No. (671) 649-7880 / 81

Ricarte Bisquera  
Quality Control Manager  
Korando Corporation  
P.O. Box 20538  
G.M.F., Guam 96921  
Tel. No. (671) 649-7880 / 81

Young Il Chung  
Site Safety and Health Officer (SSHO)  
Korando Corporation / BBR  
P.O. Box 20538  
G.M.F., Guam 96921  
Tel. No. (671) 649-7880 / 81

Nathaniel Catolos  
Project Manager  
BBR Micronesia Corp.  
P.O. Box 20337  
GMF Barrigada, Guam 96929  
Tel. No. (671) 633-7261

## 2.0 INTRODUCTION

### 2.1 Purpose

The purpose of this Water Quality Control Plan (WQCP) is to comply with the requirements in the application of Guam Environmental Protection Agency Section 401 Water Quality

Certification Application (401A) which describe the discharges from ocean outfalls and for near shore discharges. The WQMP also provides details of the Contractor's planned monitoring procedures, designed to ensure that pollution control measures are in place and working adequately.

## 2.2 General Site and Project Information

The project involves the reconstruction and widening of the BILE and PIGUA bridges to address the immediate concerns to the structural integrity of both existing bridges. The bridges are approximately 730 feet apart and located within the village of Merizo in the southern part of Guam along Route 4. These bridges will be constructed with an increased span to widen the existing river opening at the bridges. The scope of improvements entails the demolition of each bridge, which will be accomplished in two phases and the construction of a two lane bridges with shoulders, bridge rails and guardrails, all within the confines of the right-of-way along the existing Route 4 corridor. Included with this scope is the required real state acquisitions and severance maps to acquire the right-of-way corridor by the Government. In addition, the road approaches to the bridges will be reconstructed and widen to include, asphalt concrete pavement approach ramps, paved shoulders, installation of ample warning and traffic regulatory signage and pavement markers and markings to direct vehicular movement throughout the limits of this project site, and any other roadway appurtenances, where applicable, to provide for a complete, usable and safe facility.

The Bridge replacement project is located on the southwestern shoreline in Merizo District, Guam. The northern bridge, Bile, is situated approximately one-tenth of a mile north of the Pigua Bridge. The project area is located along Route 4, just south of Toguan Bay, where the two rivers (Bile and Pigua) empty into the Philippine Sea (Figure 1). Route 4 in this area is situated on level land approximately 75 m east of the eroding shoreline. The elevation of the road is 10-15 ft above sea level. Private homes, with access to the road, line both sides of the road in this area. The soil in on either side of Route 4 in the vicinity of the bridges in Inarajan clay with 0 to 4 percent slopes (Young 1988). This deep, poorly drained soil on broad valley bottoms formed in alluvium derived from volcanic rock and limestone. Much of the projects area is currently covered by pavement and concrete. Large boulders, or riprap, line the banks of the Pigua River.

- All monitoring results must be communicated to the Project Manager or Quality Control personnel and shall be maintained at the field office for record keeping.
- Photographs will be taken to documents BMP conditions and any mitigate action committed.

#### **4.1.e Depth and Location:**

The depth and location of the sampling stations are indicated in the drawing. We prepare to collect water samples at depth representing the Tidal Flux at average of 2' to 3' from the water surface.

#### **4.1.f Qualifications:**

Korando Corporation will train his staff who are conducting the sampling and reading using the Potable Hach Turbidimeter Model: 2100P. We will follow the instruction and procedure specified in the Manual including Calibration Procedure. We intent to train all personnel that are assigned to conduct the monitoring and testing to insure their qualification and integrity of the work.

#### **4.1.g Reporting:**

The designated personnel to conduct the testing must compile all data and record on the Log Book provided at the site. A copy of each data will be kept at the main office for security but the log book will remain at the site for inspector view during the inspection. A monthly reporting will be submitted to Guam EPA every two-weeks. The report will include all daily field monitoring data, incident reports if any describing the condition and attached picture including mitigation. Notification to GEPA for non-compliance will be immediately or within 24 hours from the incident. If the incident happened on the week end, effort must be done to contact GEPA personnel or reffort will be done first hour following regular business day.

### **4.2 Corrective Action**

Corrective action will be taken immediately when any BMP fails and threatens the quality of storm water runoff and or receiving waters.

### **BILE BRIDGE REPLACEMENT PROJECT AREA**











<b>Transmittal/Review/Approval</b>		FILE NAME: DOA & GWA Merizo Site Coordination Meeting	DATE: 3/30/2015		
CONTRACT NO.: GU-NH-NBIS(007)		TITLE: (Fill in Project Title/Location Here) Bile / Pigua Bridge Replacement (Construction Phase), Route 4, Merizo, Guam			
FROM (CONTRACTOR): Korando Corporation		TO: Jack Marlowe / Chief Project Rep.	SUBMITTAL NO.: 107.008-01		
		SPECS. SECTION: 107			
ENCL. NO.	NO. OF COPIES	DESCRIPTION	SPEC.SEC./PARA	SCHEDULE ACTIVITY NO.	CQC CODE
		Bile & Pigua Bridge Replacement (Construction Phase)			
1	4	Department Of Agriculture and Guam Waterworks Authority Coordination	107	A1110, A1120	A
		Meeting with Korando staff at Merizo Project Site on March 5, 2015.			
DATE NEEDED BY:					
TRANSMITTED FOR: <input type="checkbox"/> APPROVAL <input type="checkbox"/> CLARIFICATION <input type="checkbox"/> SELECTION <input checked="" type="checkbox"/> RECORD <input type="checkbox"/> VARIANCE					
It is hereby certified that the material submitted herein conforms to contract requirements and can be installed in the allocated spaces.		CONTRACTOR'S REPRESENTATIVE NAME/TITLE Ruel Remetira / Korando		SIGNATURE:	
Received By (Print Name & Sign)/Date/Time:    Jack Marlowe / Stanley    3/30/2015					
FROM:		SIGNATURE:		DATE:	
TO: Jack Marlowe / Stanley Consultants		For review/comment ( ) copies of enclosures forwarded. RETURN WITHIN ( ) WORKING DAYS, unless submittal is for record/info purposes only and there are no adverse comments.			
Received By (Print Name & Sign)/Date/Time:    Jack Marlowe / Stanley    3/30/2015					
FROM:		TO:		DATE:	
RECOMMEND / Enclosure(s) is (are):					
<input type="checkbox"/> No Exception Taken (NET)		<input type="checkbox"/> Rejected/Resubmit (Rej/R)		<input type="checkbox"/>	
<input type="checkbox"/> Exceptions As Noted (EAN)		<input type="checkbox"/> No Action Required (NAR)		<input type="checkbox"/>	
<input type="checkbox"/> Revise/Resubmit (Rev/R)		<input type="checkbox"/> Not Subject To Review (NSTR)			
REMARKS: <i>FOR INFORMATIONAL PURPOSES ONLY.</i>		<input type="checkbox"/> A. No Exceptions Taken <input type="checkbox"/> B. Exceptions As Noted <input type="checkbox"/> C. Revise / Resubmit <input type="checkbox"/> D. Rejected / Resubmit <input checked="" type="checkbox"/> E. No Action Required <input type="checkbox"/> F. Not Subject to Review		Job: GU-NH-NBIS(007) Submittal No. <i>107.008-01</i> By: <i>Richard [Signature]</i> Date: <i>4/15/15</i>	
<input type="checkbox"/> Copies of encls returned:		Action taken hereon does not supersede requirements of applicable design drawings, specifications, orders, codes or regulations or relieve the contractor or supplier from responsibility for errors or omissions.			
Copy to:		GUAM:DPW			
Received By (Print Name & Sign)/Date/Time:    _____    DATE					
CHIEF ENGINEER					



**KORANDO CORPORATION**  
**GENERAL CONTRACTOR**

P.O. BOX 20538  
 GMF, GUAM 96921  
 TEL: (671) 649-7880  
 (671) 649-7881  
 FAX: (671) 649-7882  
 EMAIL: admin\_korando@igog Guam.net

Bile and Figua Progress Site Meeting with

DOA Narratives

Date of Meeting at Merizo Project Site : March 05, 2015

Department of Agriculture

Korando: Existing condition has been inspected and recorded. Some of trees are affected and be removed but some will be trim only.

Mr. Jeffrey Quitugua comments that there are no restrictions on cutting the existing affected trees. There are available Trees at Department of Agriculture (DOA) nursery if Korando has affected trees to restore and replace. Just identify the quantity to be replant.



Identify and ~~make~~ record marine <sup>and terrestrial</sup> species other than eel and turtle that are present at the area, ~~where they go upstream during high tide and back near shoreline during low tide.~~ Please don't throw any garbage or debris that may affect species and keep cleaning/remove existing garbage present at the surface of the river. Do not block the flow of the water during clearing and grubbing and through the construction period. Remove right away if found out any debris material that blocks the water current.

*3/25/15*

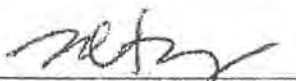
Remarks: Report findings or concerns @ 735-3955 or jeff.quitugua@yahoo.com.

Concurred by:  *3/25/15*  
 Mr. Jeffrey Quitugua  
 Technical Assistance Biologist  
 Department of Agriculture

Korando Personnel present at site:

- 1. Francisco "Joni" Palma Jr. 
- 2. Ruel Remetira 
- 3. Ricarte Bisquera 

PH 22914

# GUAM WATERWORKS AUTHORITY

578 North Marine Corp Drive Tumon, Guam 96909  
Phone: 647-7849 Fax: 649-0369

**RECEIVED**

MAR - 1 2015  
GWA  
PERMITS, INSPECTION & ET.

## REQUEST FOR WATERLINE TAP/SEWERLINE CONNECTION

Request for tap/ transmissions must be made at least five (5) working days in advance of requested tapping time. A detailed sketch of the location of the proposed tap/connection must accompany this request. Connection to main transmission/distribution lines will be permitted only during a time when consumers will not be inconvenienced. No work shall commence prior to approval of this request.

Name of Owner: GUAM DEPARTMENT OF PUBLIC WORKS  
Mailing Address: 40 KORANDO CORP.  
Location: BILE/PIGUA - MERIZO  
Service Location: \_\_\_\_\_  
Phone No.: (Home) 649 7880 (Work) 6497881 (Other) \_\_\_\_\_  
Authorized Agent: KORANDO CORP.

### APPROXIMATE SCHEDULE OF TAP/CONNECTION

Approximate Start: \_\_\_\_\_ Expected Completion: \_\_\_\_\_  
Time: \_\_\_\_\_ a.m./p.m. Time: \_\_\_\_\_ a.m./p.m.  
Date: \_\_\_\_\_ Date: \_\_\_\_\_

Size of Connection: EXPLORATORY CLEARANCE  
Type of Connection:  Water  Wastewater  Both

Applicant certifies that all necessary approvals, including road crossing have been obtained from the Department of Public Works and Utility Clearance from all Agencies involved prior to start of work.

Applicant agrees to reimburse GWA for any overtime costs incurred by GWA as a result of having a GWA representative(s) on-site during the duration of the tap/connection.

RICARTE BIZQUERA 3/11/15  
Owner's Signature/Authorized Agent Date  
KORANDO CORP

### FOR OFFICIAL USE ONLY

#### REVIEWED AND APPROVED BY:

Chun 3/10/15 \_\_\_\_\_  
Engineering Date Water Date

\_\_\_\_\_ / \_\_\_\_\_  
Wastewater Date Released Date

REMARKS: \_\_\_\_\_





**KORANDO CORPORATION**  
**GENERAL CONTRACTOR**

P.O. BOX 20538  
GMP, GUAM 96921  
TEL: (671) 649-7860  
(671) 649-7881  
FAX: (671) 649-7882  
EMAIL: admin\_korando@teleguam.net

Bile and Pigua Progress Site Meeting with  
GWA Narratives

Date of Meeting at Merizo Project Site : March 05, 2015

Guam Waterworks Authority (GWA)

Korando: Temporary water line will be constructed at bridge area. Korando will be doing any excavation for the valves and elbows installation and temporary service connection location.

Mr. Henry Bill requires Korando to process exploratory clearance before doing any excavation works to verify existing water utilities condition. Some existing lateral connections shall be installed/relocate first at its final location prior to any relocation of the main waterline. Korando shall verify the type of materials for the actual fittings to be used base on the exploration results.



Remarks:

Concurred by:

\_\_\_\_\_  
Mr. Henry Bill  
GWA

Korando Personnel present at site:

1. Francisco "Joni" Palma Jr.
2. Ruel Remetira
3. Ricarte Bisquera

\_\_\_\_\_  
  
\_\_\_\_\_  
  
\_\_\_\_\_  



<b>Transmittal/Review/Approval</b>		FILE NAME: Environmental Protection & Erosion Control Plan	DATE: 2/04/2015																				
CONTRACT NO.: GU-NH-NBIS(007)		TITLE: (Fill in Project Title/Location Here) Bile / Pigua Bridge Replacement (Construction Phase), Route 4, Merizo, Guam																					
FROM (CONTRACTOR): Korando Corporation		TO: Jack Marlowe / Chief Project Rep.	SUBMITTAL NO.: 107-002-02																				
		SPECS. SECTION: 107 & 157																					
ENCL. NO.	NO. OF COPIES	DESCRIPTION	SPEC.SEC./PARA	SCHEDULE ACTIVITY NO.	CQC CODE																		
		Bile & Pigua Bridge Replacement (Construction Phase)																					
1	22	Environmental Protection & Erosion Control Plan	107.10 & 157.03	A1050/A1070	A																		
DATE NEEDED BY:																							
TRANSMITTED FOR: <input checked="" type="checkbox"/> APPROVAL <input type="checkbox"/> CLARIFICATION <input type="checkbox"/> SELECTION <input type="checkbox"/> RECORD <input type="checkbox"/> VARIANCE																							
It is hereby certified that the material submitted herein conforms to contract requirements and can be installed in the allocated spaces.		CONTRACTOR'S REPRESENTATIVE NAME/TITLE Ruel Remetira / Korando	SIGNATURE: 																				
Received By (Print Name & Sign)/Date/Time:      Jack Marlowe / Stanley      2/04/2015																							
FROM:		SIGNATURE:	DATE:																				
TO: Jack Marlowe / Stanley Consultants		For review/comment ( ) copies of enclosures forwarded. RETURN WITHIN ( ) WORKING DAYS, unless submittal is for record/info purposes only and there are no adverse comments.																					
Received By (Print Name & Sign)/Date/Time:      Jack Marlowe / Stanley      2/04/2015																							
FROM:		TO:	DATE:																				
RECOMMEND / Enclosure(s) is (are):																							
<input type="checkbox"/> No Exception Taken (NET)		<input type="checkbox"/> Rejected/Resubmit (Rej/R)		<input type="checkbox"/> _____																			
<input type="checkbox"/> Exceptions As Noted (EAN)		<input type="checkbox"/> No Action Required (NAR)		<input type="checkbox"/> _____																			
<input type="checkbox"/> Revise/Resubmit (Rev/R)		<input type="checkbox"/> Not Subject To Review (NSTR)																					
REMARKS:	<table border="1" style="width:100%; border-collapse: collapse;"> <tr> <td>A. No Exceptions Taken</td> <td><input checked="" type="checkbox"/></td> <td>Job: GU-NH-NBIS(007)</td> </tr> <tr> <td>B. Exceptions As Noted</td> <td><input type="checkbox"/></td> <td>Submittal No. 107.002-02</td> </tr> <tr> <td>C. Revise / Resubmit</td> <td><input type="checkbox"/></td> <td>By: Jack Marlowe</td> </tr> <tr> <td>D. Rejected / Resubmit</td> <td><input type="checkbox"/></td> <td>Date: 2/26/15</td> </tr> <tr> <td>E. No Action Required</td> <td><input type="checkbox"/></td> <td></td> </tr> <tr> <td>F. Not Subject to Review</td> <td><input type="checkbox"/></td> <td></td> </tr> </table>					A. No Exceptions Taken	<input checked="" type="checkbox"/>	Job: GU-NH-NBIS(007)	B. Exceptions As Noted	<input type="checkbox"/>	Submittal No. 107.002-02	C. Revise / Resubmit	<input type="checkbox"/>	By: Jack Marlowe	D. Rejected / Resubmit	<input type="checkbox"/>	Date: 2/26/15	E. No Action Required	<input type="checkbox"/>		F. Not Subject to Review	<input type="checkbox"/>	
A. No Exceptions Taken	<input checked="" type="checkbox"/>	Job: GU-NH-NBIS(007)																					
B. Exceptions As Noted	<input type="checkbox"/>	Submittal No. 107.002-02																					
C. Revise / Resubmit	<input type="checkbox"/>	By: Jack Marlowe																					
D. Rejected / Resubmit	<input type="checkbox"/>	Date: 2/26/15																					
E. No Action Required	<input type="checkbox"/>																						
F. Not Subject to Review	<input type="checkbox"/>																						
Copy to:	<input type="checkbox"/> Copies of encls returned: ACTION TAKEN HEREON DOES NOT SUPERSEDE REQUIREMENTS OF APPLICABLE DESIGN DRAWINGS, SPECIFICATIONS, ORDERS, CODES OR REGULATIONS OR RELIEVE THE CONTRACTOR OR SUPPLIER FROM RESPONSIBILITY FOR ERRORS OR OMISSIONS. SIGNATURE: _____ GUAM DPW Received By (Print Name & Sign)/DATE/ENGINEER: _____ DATE: _____																						



**Transmittal/Review/Approval**

FILE NAME: Notice To Permit and Encroachment Permit

DATE: 01/07/2015

CONTRACT NO.: GU-NH-NBIS(007)	TITLE: (Fill in Project Title/Location Here) Bile / Pigua Bridge Replacement (Construction Phase), Route 4, Merizo, Guam
FROM (CONTRACTOR): Korando Corporation	TO: Jack Marlowe / Chief Project Rep.
	SUBMITTAL NO.: <del>107.001-01</del> 107.005-01
	SPECS. SECTION: SCR 108

ENCL. NO.	NO. OF COPIES	DESCRIPTION	SPEC.SEC./PARA	SCHEDULE ACTIVITY NO.	CQC CODE
		Bile & Pigua Bridge Replacement (Construction Phase)			
1	6	<del>Notice To Permit (NTP) and</del> Encroachment Permit	SCR <del>108-01</del> 107-01	A1000 / A1090	A

DATE NEEDED BY:

TRANSMITTED FOR:  APPROVAL  CLARIFICATION  SELECTION  RECORD  VARIANCE

*It is hereby certified that the material submitted herein conforms to contract requirements and can be installed in the allocated spaces.*

CONTRACTOR'S REPRESENTATIVE NAME/TITLE: Ruel Remetira / Korando

SIGNATURE: 

Received By (Print Name & Sign)/Date/Time: Jack Marlowe / Stanley 01/07/2014

FROM: SIGNATURE: DATE:

TO: Jack Marlowe / Stanley Consultants

*For review/comment ( ) copies of enclosures forwarded. RETURN WITHIN ( ) WORKING DAYS, unless submittal is for record/info purposes only and there are no adverse comments.*

Received By (Print Name & Sign)/Date/Time: Jack Marlowe / Stanley 01/07/2014

FROM: TO: DATE:

RECOMMEND / Enclosure(s) is (are):

No Exception Taken (NET)  Rejected/Resubmit (Rej/R)  \_\_\_\_\_

Exceptions As Noted (EAN)  No Action Required (NAR)  \_\_\_\_\_

Revise/Resubmit (Rev/R)  Not Subject To Review (NSTR)

REMARKS: FOR INFORMATIONAL PURPOSES ONLY.

Copies of encls returned:

Copy to:

A. No Exceptions Taken <input type="checkbox"/> B. Exceptions As Noted <input type="checkbox"/> C. Revise / Resubmit <input type="checkbox"/> D. Rejected / Resubmit <input type="checkbox"/> E. No Action Required <input checked="" type="checkbox"/> F. Not Subject to Review <input type="checkbox"/>	Job: GU-NH-NBIS(007) Submittal No. 107.005-01 By:  Date: 1/8/15
Action taken hereon does not supersede requirements of applicable design drawings, specifications, orders, codes or regulations or relieve the contractor or supplier from responsibility for errors or omissions.	
GUAM DPW Received By (Print Name & Sign)/Date/Time: _____ CHIEF ENGINEER. DATE	



**Transmittal/Review/Approval** FILE NAME: Hazard Analysis Critical Control Points (HACCP) Plan DATE: 2/18/2015

CONTRACT NO.: GU-NH-NBIS(007)	TITLE: (Fill in Project Title/Location Here) Bile / Pigua Bridge Replacement (Construction Phase), Route 4, Merizo, Guam		
FROM (CONTRACTOR): Korando Corporation	TO: Jack Marlowe / Chief Project Rep.	SUBMITTAL NO.: 107.005-02	SPECS. SECTION: 107

ENCL. NO.	NO. OF COPIES	DESCRIPTION	SPEC.SEC./PARA	SCHEDULE ACTIVITY NO.	CQC CODE
		Bile & Pigua Bridge Replacement (Construction Phase)			
I	36	Hazard Analysis Critical Control Points (HACCP) Plan (Department of Agriculture (DOA) - NET)	SCR 107.10.c.1	A1110	A

DATE NEEDED BY:

TRANSMITTED FOR:  APPROVAL     CLARIFICATION     SELECTION     RECORD     VARIANCE

*It is hereby certified that the material submitted herein conforms to contract requirements and can be installed in the allocated spaces.*

CONTRACTOR'S REPRESENTATIVE NAME/TITLE: Ricarte Bisquera / Korando

SIGNATURE: 

Received By (Print Name & Sign)/Date/Time: Jack Marlowe / Stanley 2/18/2015

FROM:	SIGNATURE:	DATE:
-------	------------	-------

TO: Jack Marlowe / Stanley Consultants

*For review/comment ( ) copies of enclosures forwarded. RETURN WITHIN ( ) WORKING DAYS, unless submittal is for record/info purposes only and there are no adverse comments.*

Received By (Print Name & Sign)/Date/Time: Jack Marlowe / Stanley 2/18/2015

FROM:	TO:	DATE:
-------	-----	-------

RECOMMEND / Enclosure(s) is (are):

<input type="checkbox"/> No Exception Taken (NET)	<input type="checkbox"/> Rejected/Resubmit (Rej/R)	<input type="checkbox"/> _____
<input type="checkbox"/> Exceptions As Noted (EAN)	<input type="checkbox"/> No Action Required (NAR)	<input type="checkbox"/> _____
<input type="checkbox"/> Revise/Resubmit (Rev/R)	<input type="checkbox"/> Not Subject To Review (NSTR)	

REMARKS:

Copies of encls returned:

Copy to: \_\_\_\_\_ SIGNATURE: \_\_\_\_\_

Received By (Print Name & Sign)/Date/Time: \_\_\_\_\_

<b>Transmittal/Review/Approval</b>		FILE NAME: Hazard Analysis Critical Control Points (HACCP) Plan	DATE: 1/29/2015		
CONTRACT NO.: GU-NH-NBIS(007)		TITLE: (Fill in Project Title/Location Here) Bile / Pigua Bridge Replacement (Construction Phase), Route 4, Merizo, Guam			
FROM (CONTRACTOR): Korando Corporation		TO: Jeff Quitugua / Department of Agriculture	SUBMITTAL NO.: 107.005-01		
		SPECS. SECTION: 107			
ENCL. NO.	NO. OF COPIES	DESCRIPTION	SPEC.SEC./PARA	SCHEDULE ACTIVITY NO.	CCC CODE
		Bile & Pigua Bridge Replacement (Construction Phase)			
1	33	Hazard Analysis Critical Control Points (HACCP) Plan	SCR 107.10.e.1	A1110	A
DATE NEEDED BY:					
TRANSMITTED FOR: <input checked="" type="checkbox"/> APPROVAL <input type="checkbox"/> CLARIFICATION <input type="checkbox"/> SELECTION <input type="checkbox"/> RECORD <input type="checkbox"/> VARIANCE					
It is hereby certified that the material submitted herein conforms to contract requirements and can be installed in the allocated spaces.		CONTRACTOR'S REPRESENTATIVE NAME/TITLE Ricarte Bisquera / Korando		SIGNATURE:	
Received By (Print Name & Sign)/Date/Time:    Jeff Quitugua / Dept. of Agriculture    1/29/2015					
FROM:		SIGNATURE:		DATE:	
TO: Jack Marlown / Stanley Consultants		For review/comment ( ) copies of enclosures forwarded. RETURN WITHIN ( ) WORKING DAYS, unless submittal is for record/info purposes only and there are no adverse comments.			
Received By (Print Name & Sign)/Date/Time:    Jeff Quitugua / Dept. of Agriculture    1/29/2015					
FROM: Department of Agriculture		TO: Korando Corporation		DATE: 02/16/15	
RECOMMEND / Enclosure(s) is (are):					
<input type="checkbox"/> No Exception Taken (NET)		<input type="checkbox"/> Rejected/Resubmit (Rej/R)		<input type="checkbox"/> _____	
<input checked="" type="checkbox"/> Exceptions As Noted (EAN)		<input type="checkbox"/> No Action Required (NAR)		<input type="checkbox"/> _____	
<input type="checkbox"/> Revise/Resubmit (Rev/R)		<input type="checkbox"/> Not Subject To Review (NSTR)			
REMARKS:					
Please see attached.					
Copy to: <input checked="" type="checkbox"/> Copies of encls returned:		SIGNATURE: _____			
Received By (Print Name & Sign)/Date/Time:					

DAWN WOS  
**RECEIVED**  
 JAN 29 2015  
 #0168  
 At 2/3/2015  
 copy to:  
 Fisheries  
 Wildlife  
 2/3/15





**Department of Agriculture  
Dipattamenton Agrikottura**  
163 Dairy Road, Mangilao, Guam 96913



**Edward J.B. Calvo**  
Governor

**Raymond S. Tenorio**  
Lt. Governor

Director's Office  
Agricultural Dev. Services  
Animal Health  
Aquatic & Wildlife Resources  
Forestry & Soil Resources  
Plant Nursery  
Plant Inspection Facility

300-7954/65/66; Fax 734-6569  
300-7972/73/67; Fax 734-6569  
300-7965/66; Fax 734-6569  
735-3955/56; Fax 734-6570  
300-7975/76; Fax 734-6569  
300-7974; Fax 734-6569  
475-1426/27; Fax 477-9487

**Mariquita F. Taitague**  
Director

**Matthew L.G. Sablan**  
Deputy Director

February 13, 2015

Mr. Ruel Z. Remetira  
Korando Corporation  
P.O. Box 20538  
GMF, GU 96921

**Re: GU-NH-NBIS (007), Hazard Analysis Critical Control Points (HACCP) Plan for Bile / Pigua Bridge Replacement (Construction Phase), Route 4, Merizo, Guam**

Dear Mr. Remetira:

Hafa Adai! The Korando Corporation and unnamed subcontractors were awarded the project for the replacement (construction) of Bile and Pigua Bridge, along Route 4, Merizo. On January 29, 2015, a Hazard Analysis critical Control Points (HACCP) Plan for the Construction Phase was submitted to the Department of Agriculture's Division of Aquatic & Wildlife Resources (DAWR) for review and approval.

The HACCP Plan submitted identifies Best Management Practices (BMPs) in effort to minimize or avoid impacts to the natural resources (present or may be present) at the project site. DAWR acknowledges Korando Corp's efforts. Depending on the daily project scenario (i.e.: drastic weather conditions, occurrence of protected species, etc.), the contractor should be flexible with implementing BMPs that are not described in the HACCP Plan as presented during the review and approval process. Consultation with DAWR throughout the duration of the project is encouraged.

The HACCP Plan states the estimated construction dates for the project (start date is on January 05, 2015, and completion date is on March 29, 2016). The duration of the project falls on the winter season, when migratory birds occur on island. Migratory birds are federally protected species under the U.S. Migratory Bird Treaty Act of 1917. DAWR has obtained data of migratory birds observed along the river's end near the shore of the Bile and Pigua Bridge. The HACCP Plan fails to identify migratory bird species in their actions. Efforts to minimize or avoid impacts to migratory birds should be implemented during the construction phase. The HACCP Plan does not indicate the actual daily hours for the construction. If nighttime work is considered, DAWR recommends that spotlights used at the site face the upland direction to avoid any harm to the sea turtles that may occur near the site.

A Staging and Field Office (SFO) area is identified in the HACCP Plan (page 3, Figure 1 – Location Map). The area is a privately owned mowed field. DAWR has collected data identifying the area used by migratory birds between October to March in previous years at this site. Korando Corp is requested to be mindful of the presence of these protected species in the area during the wintering months. In addition, take precautionary actions to prevent any harmful oils/fuels to enter the environment in the area.

DAWR would like to acknowledge your efforts in protecting our environment. We are confident that Korando Corp will continue to be a steward to our natural resources on Guam by implementing BMPs in their projects. Should you have any questions or concerns, please contact Technical Assistance Biologist, Mr. Jeffrey S. Quitugua, via email at [jeff.quitugua@yahoo.com](mailto:jeff.quitugua@yahoo.com), or via phone, at 735-3955/56.

Sincerely,

  
MARIQUITA F. TAITAGUE

cc: Bureau of Statistics and Plans – Coastal Zone Management Program



**ATTACHMENT B**

*Bile / Pigua Bridge Replacement (Construction Phase)*  
*Project No.: GU-NH-NBIS(007)*

MINIMUM WAGE RATES – FEDERAL HIGHWAY FUNDED PROJECTS  
(NON DEPARTMENT OF DEFENSE)

General Decision Number: GU130001 01/04/2013 GU1

Superseded General Decision Number: GU20120001

State: Guam

Construction Types: Building, Heavy, Highway and Residential

(Excludes any projects funded under the National Defense  
 Authorization Act 2010 - Guam Realignment Fund - Defense Policy  
 Review Initiative)

County: Guam Statewide.

BUILDING, HEAVY, HIGHWAY AND RESIDENTIAL

Modification Number      Publication Date  
 0                              01/04/2013

SUGU2010-001 09/20/2010

	Rates	Fringes
BRICKLAYER.....	\$ 14.02	
CARPENTER.....	\$ 13.56	
Cement mason.....	\$ 12.87	
Electrician.....	\$ 15.45	
Heavy Equipment Mechanic.....	\$ 14.14	
Heavy Equipment Operator.....	\$ 13.77	
IRONWORKER		
Reinforcing.....	\$ 12.56	
Structural.....	\$ 13.22	
PAINTER.....	\$ 14.60	
Pipefitters.....	\$ 16.80	
PLASTERER.....	\$ 10.98	
PLUMBER.....	\$ 14.96	

REFRIGERATION MECHANIC  
including Heating, Air  
Conditioning (HVAC)  
Mechanic work.....\$ 15.73

SHEETMETAL WORKER.....\$ 15.17

WELDER.....\$ 16.09

-----  
WELDERS - Receive rate prescribed for craft performing  
operation to which welding is incidental.

=====

Unlisted classifications needed for work not included within  
the scope of the classifications listed may be added after  
award only as provided in the labor standards contract clauses  
(29CFR 5.5 (a) (1) (ii)).

-----

The body of each wage determination lists the classification  
and wage rates that have been found to be prevailing for the  
cited type(s) of construction in the area covered by the wage  
determination. The classifications are listed in alphabetical  
order of "identifiers" that indicate whether the particular  
rate is union or non-union.

#### Union Identifiers

An identifier enclosed in dotted lines beginning with  
characters other than "SU" denotes that the union  
classification and rate have found to be prevailing for that  
classification. Example: PLUM0198-005 07/01/2011. The first  
four letters, PLUM, indicate the international union and the  
four-digit number, 0198, that follows indicates the local union  
number or district council number where applicable, i.e.,  
Plumbers Local 0198. The next number, 005 in the example, is  
an internal number used in processing the wage determination.  
The date, 07/01/2011, following these characters is the  
effective date of the most current negotiated rate/collective  
bargaining agreement which would be July 1, 2011 in the above  
example.

Union prevailing wage rates will be updated to reflect any  
changes in the collective bargaining agreements governing the  
rates.

0000/9999: weighted union wage rates will be published annually  
each January.



Non-Union Identifiers

Classifications listed under an "SU" identifier were derived from survey data by computing average rates and are not union rates; however, the data used in computing these rates may include both union and non-union data. Example: SULA2004-007 5/13/2010. SU indicates the rates are not union majority rates, LA indicates the State of Louisiana; 2004 is the year of the survey; and 007 is an internal number used in producing the wage determination. A 1993 or later date, 5/13/2010, indicates the classifications and rates under that identifier were issued as a General Wage Determination on that date.

Survey wage rates will remain in effect and will not change until a new survey is conducted.

-----  
WAGE DETERMINATION APPEALS PROCESS

1.) Has there been an initial decision in the matter? This can be:

- \* an existing published wage determination
- \* a survey underlying a wage determination
- \* a Wage and Hour Division letter setting forth a position on a wage determination matter
- \* a conformance (additional classification and rate) ruling

On survey related matters, initial contact, including requests for summaries of surveys, should be with the Wage and Hour Regional Office for the area in which the survey was conducted because those Regional Offices have responsibility for the Davis-Bacon survey program. If the response from this initial contact is not satisfactory, then the process described in 2.) and 3.) should be followed.

With regard to any other matter not yet ripe for the formal process described here, initial contact should be with the Branch of Construction Wage Determinations. Write to:

Branch of Construction Wage Determinations  
Wage and Hour Division  
U.S. Department of Labor  
200 Constitution Avenue, N.W.  
Washington, DC 20210

2.) If the answer to the question in 1.) is yes, then an interested party (those affected by the action) can request review and reconsideration from the Wage and Hour Administrator (See 29 CFR Part 1.8 and 29 CFR Part 7). Write to:

Wage and Hour Administrator  
U.S. Department of Labor  
200 Constitution Avenue, N.W.  
Washington, DC 20210

MINIMUM WAGE RATES

MWR-3

*Bile / Pigua Bridge Replacement (Construction Phase)*  
*Project No.: GU-NH-NBLS(007)*

The request should be accompanied by a full statement of the interested party's position and by any information (wage payment data, project description, area practice material, etc.) that the requestor considers relevant to the issue.

3.) If the decision of the Administrator is not favorable, an interested party may appeal directly to the Administrative Review Board (formerly the Wage Appeals Board). Write to:

Administrative Review Board  
U.S. Department of Labor  
200 Constitution Avenue, N.W.  
Washington, DC 20210

4.) All decisions by the Administrative Review Board are final.

=====

END OF GENERAL DECISION

\*\*\*END OF MINIMUM WAGE RATES\*\*\*



Project: Bile / Pigua Bridge Replacement (Construction Phase)  
Along Route 4 Merizo, Guam  
Project number: GU-NH-NBIS (007)

**CERTIFIED PAYROLL**  
**Reports Log Sheet**

Payroll Number	For Week Ending	Date CPR - Submit	DAYS Past Due	Comments
1	1/11/2015	1/27/2015	11	
2	1/18/2015	1/27/2015	4	
3	1/25/2015	01/27/215	0	
4	2/1/2015	2/10/2015	4	
5	2/8/2015	2/10/2015	0	
6	2/15/2015	2/24/2015	4	
7	2/22/2015	2/24/2015	0	
8	3/1/2015	3/10/2015	4	
9	3/8/2015	3/10/2015	0	
10	3/15/2015	3/17/2015	0	
11	3/22/2015	4/28/2015	32	
12	3/29/2015	4/28/2015	25	
13	4/5/2015	4/28/2015	18	
14	4/12/2015	4/28/2015	11	
15	4/19/2015	4/28/2015	4	
16	4/26/2015	4/28/2015	0	
17	5/3/2015	5/14/2015	6	
18	5/10/2015	5/14/2015	0	
19	5/17/2015	5/26/2015	4	
20	5/24/2015	6/2/2015	4	
21	5/31/2015	6/11/2015	6	
22	6/7/2015	6/11/2015	0	
23	6/14/2015	6/22/2015	3	
15A	4/19/2015	6/22/2015	Revised	E. Pascua (HEO) not reported on CPR (8.5 hours, 4/17/15) Production Report reflects for specified day of work hours
15A	03/22-06/07/2015	6/22/2015	Revised	Reflecting the difference in wage of \$1.28 and \$9.78 should be the rate used in lieu of \$8.50
24	06/21/215	7/1/2015	5	
25	6/28/2015	7/1/2015	0	



PAYROLL

(For Contractor's Optional Use; See Instructions at [www.dol.gov/whd/forms/wh347instr.htm](http://www.dol.gov/whd/forms/wh347instr.htm))

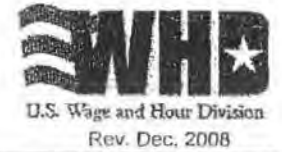

Persons are not required to respond to the collection of information unless it displays a currently valid OMB control number.

NAME OF CONTRACTOR <input checked="" type="checkbox"/> OR SUBCONTRACTOR <input type="checkbox"/> <b>KORANDO CORPORATION</b>	ADDRESS P.O. BOX 20538 BARRIGADA, GUAM 96921	OMB No.: 1235-0008 Expires: 01/31/2015
PAYROLL NO. 1	FOR WEEK ENDING 01/11/2015	PROJECT AND LOCATION Bile/Pigua Bridge Replacement (Construction Phase) Along Route 4, Merizo, Guam
		PROJECT OR CONTRACT NO. GU-NH-NBIS (007)

(1) NAME AND INDIVIDUAL IDENTIFYING NUMBER (e.g., LAST FOUR DIGITS OF SOCIAL SECURITY NUMBER) OF WORKER	(2) NO. OF WITHHOLDING DESIGNATIONS	(3) WORK CLASSIFICATION	OT OR ST.	(4) DAY AND DATE							(5) TOTAL HOURS	(6) RATE OF PAY	(7) GROSS AMOUNT EARNED	(8) DEDUCTIONS					(9) NET WAGES PAID FOR WEEK
				M	T	W	TH	F	SA	SU				FICA	WITH- HOLDING TAX	OTHER	TOTAL DEDUCTIONS		
				5	6	7	8	9	10	11				HOURS WORKED EACH DAY					
			O																
			S																
			O																
			S																
			O																
			S																
			O																
			S																
			O																
			S																
			O																
			S																

While completion of Form WH-347 is optional, it is mandatory for covered contractors and subcontractors performing work on Federally financed or assisted construction contracts to respond to the information collection contained in 29 C.F.R. §§ 3.3, 5.5(a). The Copeland Act (40 U.S.C. § 3145) contractors and subcontractors performing work on Federally financed or assisted construction contracts to "furnish weekly a statement with respect to the wages paid each employee during the preceding week." U.S. Department of Labor (DOL) regulations at 29 C.F.R. § 5.5(a)(3)(i) require contractors to submit weekly a copy of all payrolls to the Federal agency contracting for or financing the construction project, accompanied by a signed "Statement of Compliance" indicating that the payrolls are correct and complete and that each laborer or mechanic has been paid not less than the proper Davis-Bacon prevailing wage rate for the work performed. DOL and federal contracting agencies receiving this information review the information to determine that employees have received legally required wages and fringe benefits.

Public Burden Statement

We estimate that it will take an average of 55 minutes to complete this collection, including time for reviewing instructions, searching existing data sources, gathering and maintaining the data needed, and completing and reviewing the collection of information. If you have any comments regarding these estimates or any other aspect of this collection, including suggestions for reducing this burden, send them to the Administrator, Wage and Hour Division, U.S. Department of Labor, Room S3502, 200 Constitution Avenue, N.W. Washington, D.C. 20210



Date 01/16/2015

I, HYON SANG KIM OPERATIONS MANAGER  
(Name of Signatory Party) (Title)

do hereby state:

(1) That I pay or supervise the payment of the persons employed by

KORANDO CORPORATION on the  
(Contractor or Subcontractor)  
380H Harmon Industrial Park, Tamuning, GU; that during the payroll period commencing on the  
(Building or Work)  
05 day of January, 2015, and ending the 11 day of January, 2015

for persons employed on said project have been paid the full weekly wages earned, that no rebates have been or will be made either directly or indirectly to or on behalf of said

KORANDO CORPORATION from the full  
(Contractor or Subcontractor)

weekly wages earned by any person and that no deductions have been made either directly or indirectly from the full wages earned by any person, other than permissible deductions as defined in Regulations, Part 3 (29 C.F.R. Subtitle A), issued by the Secretary of Labor under the Copeland Act, as amended (48 Stat. 948, 63 Stat. 108, 72 Stat. 967; 76 Stat. 357; 40 U.S.C. § 3145), and described below:

\_\_\_\_\_  
\_\_\_\_\_  
\_\_\_\_\_

(2) That any payrolls otherwise under this contract required to be submitted for the above period are correct and complete; that the wage rates for laborers or mechanics contained therein are not less than the applicable wage rates contained in any wage determination incorporated into the contract; that the classifications set forth therein for each laborer or mechanic conform with the work he performed.

(3) That any apprentices employed in the above period are duly registered in a bona fide apprenticeship program registered with a State apprenticeship agency recognized by the Bureau of Apprenticeship and Training, United States Department of Labor, or if no such recognized agency exists in a State, are registered with the Bureau of Apprenticeship and Training, United States Department of Labor.

(4) That:

(a) WHERE FRINGE BENEFITS ARE PAID TO APPROVED PLANS, FUNDS, OR PROGRAMS

- in addition to the basic hourly wage rates paid to each laborer or mechanic listed in the above referenced payroll, payments of fringe benefits as listed in the contract have been or will be made to appropriate programs for the benefit of such employees, except as noted in section 4(c) below.

(b) WHERE FRINGE BENEFITS ARE PAID IN CASH

- Each laborer or mechanic listed in the above referenced payroll has been paid, as indicated on the payroll, an amount not less than the sum of the applicable basic hourly wage rate plus the amount of the required fringe benefits as listed in the contract, except as noted in section 4(c) below.

(c) EXCEPTIONS

EXCEPTION (CRAFT)	EXPLANATION

REMARKS:  
NO ACTIVITY  
  
**received**  
1/27/15 3:00PM  
C. RICHARDS

NAME AND TITLE: Hyon Sang Kim / Operations Manager  
SIGNATURE: *[Handwritten Signature]*

THE WILLFUL FALSIFICATION OF ANY OF THE ABOVE STATEMENTS MAY SUBJECT THE CONTRACTOR OR SUBCONTRACTOR TO CIVIL OR CRIMINAL PROSECUTION. SEE SECTION 1001 OF TITLE 18 AND SECTION 231 OF TITLE 31 OF THE UNITED STATES CODE.

**PAYROLL**

(For Contractor's Optional Use; See Instructions at [www.dol.gov/whd/forms/wh347instr.htm](http://www.dol.gov/whd/forms/wh347instr.htm))



Persons are not required to respond to the collection of information unless it displays a currently valid OMB control number.

NAME OF CONTRACTOR <input checked="" type="checkbox"/> OR SUBCONTRACTOR <input type="checkbox"/> KORANDO CORPORATION	ADDRESS P.O. BOX 20538 BARRIGADA, GUAM 96921	OMB No.: 1235-0008 Expires: 01/31/2015
PAYROLL NO. 2	FOR WEEK ENDING 01/18/2015	PROJECT AND LOCATION Bile/Pigua Bridge Replacement (Construction Phase) Along Route 4, Merizo, Guam
		PROJECT OR CONTRACT NO. GU-NH-NBIS (007)

(1) NAME AND INDIVIDUAL IDENTIFYING NUMBER (e.g., LAST FOUR DIGITS OF SOCIAL SECURITY NUMBER) OF WORKER	(2) NO. OF WITHHOLDING EXEMPTIONS	(3) WORK CLASSIFICATION	(4) DAY AND DATE							(5) TOTAL HOURS	(6) RATE OF PAY	(7) GROSS AMOUNT EARNED	(8) DEDUCTIONS					(9) NET WAGES PAID FOR WEEK
			OT OR ST.	M	T	W	TH	F	SA				SU	FICA	WITH- HOLDING TAX	OTHER	TOTAL DEDUCTIONS	
				12	13	14	15	16	17				18					
			HOURS WORKED EACH DAY															
			O															
			S															
			O															
			S															
			O															
			S															
			O															
			S															
			O															
			S															
			O															
			S															
			O															
			S															

While completion of Form WH-347 is optional, it is mandatory for covered contractors and subcontractors performing work on Federally financed or assisted construction contracts to respond to the information collection contained in 29 C.F.R. §§ 3.3, 5.5(a). The Copeland Act (40 U.S.C. § 3145) contractors and subcontractors performing work on Federally financed or assisted construction contracts to "furnish weekly a statement with respect to the wages paid each employee during the preceding week." U.S. Department of Labor (DOL) regulations at 29 C.F.R. § 5.5(e)(3)(ii) require contractors to submit weekly a copy of all payrolls to the Federal agency contracting for or financing the construction project, accompanied by a signed "Statement of Compliance" indicating that the payrolls are correct and complete and that each laborer or mechanic has been paid not less than the proper Davis-Bacon prevailing wage rate for the work performed. DOL and federal contracting agencies receiving this information review the information to determine that employees have received legally required wages and fringe benefits.

**Public Burden Statement**

We estimate that it will take an average of 55 minutes to complete this collection, including time for reviewing instructions, searching existing data sources, gathering and maintaining the data needed, and completing and reviewing the collection of information. If you have any comments regarding these estimates or any other aspect of this collection, including suggestions for reducing this burden, send them to the Administrator, Wage and Hour Division, U.S. Department of Labor, Room S3502, 200 Constitution Avenue, N.W., Washington, D.C. 20210



Date 01/23/2015

I, HYON SANG KIM OPERATIONS MANAGER  
(Name of Signatory Party) (Title)

do hereby state:

(1) That I pay or supervise the payment of the persons employed by

KORANDO CORPORATION

(Contractor or Subcontractor)

on the

380H Harmon Industrial Park, Tamuning, GU; that during the payroll period commencing on the

(Building or Work)

12 day of January, 2015, and ending the 18 day of January, 2015,

all persons employed on said project have been paid the full weekly wages earned, that no rebates have been or will be made either directly or indirectly to or on behalf of said

KORANDO CORPORATION

(Contractor or Subcontractor)

from the full

weekly wages earned by any person and that no deductions have been made either directly or indirectly from the full wages earned by any person, other than permissible deductions as defined in Regulations, Part 3 (29 C.F.R. Subtitle A), issued by the Secretary of Labor under the Copeland Act, as amended (48 Stat. 948, 63 Stat. 108, 72 Stat. 967, 75 Stat. 357; 40 U.S.C. § 3145), and described below.

\_\_\_\_\_  
\_\_\_\_\_  
\_\_\_\_\_

(2) That any payrolls otherwise under this contract required to be submitted for the above period are correct and complete; that the wage rates for laborers or mechanics contained therein are not less than the applicable wage rates contained in any wage determination incorporated into the contract; that the classifications set forth therein for each laborer or mechanic conform with the work he performed.

(3) That any apprentices employed in the above period are duly registered in a bona fide apprenticeship program registered with a State apprenticeship agency recognized by the Bureau of Apprenticeship and Training, United States Department of Labor, or if no such recognized agency exists in a State, are registered with the Bureau of Apprenticeship and Training, United States Department of Labor.

(4) That

(a) WHERE FRINGE BENEFITS ARE PAID TO APPROVED PLANS, FUNDS, OR PROGRAMS

- In addition to the basic hourly wage rates paid to each laborer or mechanic listed in the above referenced payroll, payments of fringe benefits as listed in the contract have been or will be made to appropriate programs for the benefit of such employees, except as noted in section 4(c) below.

(b) WHERE FRINGE BENEFITS ARE PAID IN CASH

- Each laborer or mechanic listed in the above referenced payroll has been paid, as indicated on the payroll, an amount not less than the sum of the applicable basic hourly wage rate plus the amount of the required fringe benefits as listed in the contract, except as noted in section 4(c) below.

(c) EXCEPTIONS

EXCEPTION (CRAFT)	EXPLANATION

REMARKS:

NO ACTIVITY

**received**  
C. RICHARDS  
1/27/15 3:00 PM

NAME AND TITLE

Hyon Sang Kim / Operations Manager

SIGNATURE

THE WILLFUL FALSIFICATION OF ANY OF THE ABOVE STATEMENTS MAY SUBJECT THE CONTRACTOR OR SUBCONTRACTOR TO CIVIL OR CRIMINAL PROSECUTION. SEE SECTION 1001 OF TITLE 18 AND SECTION 231 OF TITLE 31 OF THE UNITED STATES CODE.



PAYROLL

(For Contractor's Optional Use; See Instructions at [www.dol.gov/whd/forms/wh347instr.htm](http://www.dol.gov/whd/forms/wh347instr.htm))



Rev. Dec. 2008

Persons are not required to respond to the collection of information unless it displays a currently valid OMB control number.

NAME OF CONTRACTOR <input checked="" type="checkbox"/> OR SUBCONTRACTOR <input type="checkbox"/>		ADDRESS		OMB No.: 1235-0008	
KORANDO CORPORATION		P.O. BOX 20538 BARRIGADA, GUAM 96921		Expires: 01/31/2015	
PAYROLL NO. 3	FOR WEEK ENDING 01/25/2015	PROJECT AND LOCATION Bile/Pigua Bridge Replacement (Construction Phase) Along Route 4, Merizo, Guam		PROJECT OR CONTRACT NO. GU-NH-NBIS (007)	

(1) NAME AND INDIVIDUAL IDENTIFYING NUMBER (e.g., LAST FOUR DIGITS OF SOCIAL SECURITY NUMBER) OF WORKER	(2) NO. OF WITHHOLDING EXEMPTIONS	(3) WORK CLASSIFICATION	(4) DAY AND DATE							(5) TOTAL HOURS	(6) RATE OF PAY	(7) GROSS AMOUNT EARNED	(8) DEDUCTIONS					(9) NET WAGES PAID FOR WEEK		
			OT. OR ST.	M	T	W	TH	F	SA				SU	FICA	WITH- HOLDING TAX	TOTAL	OTHER		TOTAL DEDUCTIONS	
				19	20	21	22	23	24				25							HOURS WORKED EACH DAY
			O																	
			S																	
			O																	
			S																	
			O																	
			S																	
			O																	
			S																	
			O																	
			S																	
			O																	
			S																	

While completion of Form WH-347 is optional, it is mandatory for covered contractors and subcontractors performing work on Federally financed or assisted construction contracts to respond to the information collection contained in 29 C.F.R. §§ 3.3, 5.5(a). The Copeland Act (40 U.S.C. § 3145) contractors and subcontractors performing work on Federally financed or assisted construction contracts to "furnish weekly a statement with respect to the wages paid each employee during the preceding week." U.S. Department of Labor (DOL) regulations at 29 C.F.R. § 5.5(a)(3)(ii) require contractors to submit weekly a copy of all payrolls to the Federal agency contracting for or financing the construction project, accompanied by a signed "Statement of Compliance" indicating that the payrolls are correct and complete and that each laborer or mechanic has been paid not less than the proper Davis-Bacon prevailing wage rate for the work performed. DOL and federal contracting agencies receiving this information review the information to determine that employees have received legally required wages and fringe benefits.

Public Burden Statement

We estimate that it will take an average of 55 minutes to complete this collection, including time for reviewing instructions, searching existing data sources, gathering and maintaining the data needed, and completing and reviewing the collection of information. If you have any comments regarding these estimates or any other aspect of this collection, including suggestions for reducing this burden, send them to the Administrator, Wage and Hour Division, U.S. Department of Labor, Room S3502, 200 Constitution Avenue, N.W., Washington, D.C. 20210

Date 01/26/2015

I, HYON SANG KIM OPERATIONS MANAGER  
(Name of Signatory Party) (Title)

do hereby state:

(1) That I pay or supervise the payment of the persons employed by

KORANDO CORPORATION on the  
(Contractor or Subcontractor)

380H Harmon Industrial Park, Tamuning, GU; that during the payroll period commencing on the  
(Building or Work)

19 day of January, 2015, and ending the 25 day of January, 2015,

if persons employed on said project have been paid the full weekly wages earned, that no rebates have been or will be made either directly or indirectly to or on behalf of said

KORANDO CORPORATION from the full  
(Contractor or Subcontractor)

weekly wages earned by any person and that no deductions have been made either directly or indirectly from the full wages earned by any person, other than permissible deductions as defined in Regulations, Part 3 (29 C.F.R. Subtitle A), issued by the Secretary of Labor under the Copeland Act, as amended (48 Stat. 948, 63 Stat. 108, 72 Stat. 957; 76 Stat. 357; 40 U.S.C. § 3145), and described below:

(2) That any payrolls otherwise under this contract required to be submitted for the above period are correct and complete; that the wage rates for laborers or mechanics contained therein are not less than the applicable wage rates contained in any wage determination incorporated into the contract; that the classifications set forth therein for each laborer or mechanic conform with the work he performed.

(3) That any apprentices employed in the above period are duly registered in a bona fide apprenticeship program registered with a State apprenticeship agency recognized by the Bureau of Apprenticeship and Training, United States Department of Labor, or if no such recognized agency exists in a State, are registered with the Bureau of Apprenticeship and Training, United States Department of Labor.

(4) That:

(a) WHERE FRINGE BENEFITS ARE PAID TO APPROVED PLANS, FUNDS, OR PROGRAMS

- in addition to the basic hourly wage rates paid to each laborer or mechanic listed in the above referenced payroll, payments of fringe benefits as listed in the contract have been or will be made to appropriate programs for the benefit of such employees, except as noted in section 4(c) below.

(b) WHERE FRINGE BENEFITS ARE PAID IN CASH

- Each laborer or mechanic listed in the above referenced payroll has been paid, as indicated on the payroll, an amount not less than the sum of the applicable basic hourly wage rate plus the amount of the required fringe benefits as listed in the contract, except as noted in section 4(c) below.

(c) EXCEPTIONS

EXCEPTION (CRAFT)	EXPLANATION

REMARKS:

NO ACTIVITY

**received**  
01/27/15 3:00PM  
C. PUGHARAS

NAME AND TITLE  
Hyon Sang Kim / Operations Manager

SIGNATURE  
*Hyon Sang Kim*

THE WILLFUL FALSIFICATION OF ANY OF THE ABOVE STATEMENTS MAY SUBJECT THE CONTRACTOR OR SUBCONTRACTOR TO CIVIL OR CRIMINAL PROSECUTION. SEE SECTION 1001 OF TITLE 18 AND SECTION 231 OF TITLE 31 OF THE UNITED STATES CODE.



U.S. Department of Labor  
Wage and Hour Division

PAYROLL

(For Contractor's Optional Use; See Instructions at [www.dol.gov/whd/forms/wh347instr.htm](http://www.dol.gov/whd/forms/wh347instr.htm))



U.S. Wage and Hour Division  
Rev. Dec. 2008

Persons are not required to respond to the collection of information unless it displays a currently valid OMB control number.

NAME OF CONTRACTOR <input checked="" type="checkbox"/> OR SUBCONTRACTOR <input type="checkbox"/>		ADDRESS		OMB No.: 1235-0008 Expires: 01/31/2015	
KORANDO CORPORATION		P.O. BOX 20538 BARRIGADA, GUAM 96921			
PAYROLL NO. 4	FOR WEEK ENDING 02/01/2015	PROJECT AND LOCATION Bile/Pigua Bridge Replacement (Construction Phase) Along Route 4, Merizo, Guam		PROJECT OR CONTRACT NO. GU-NH-NBIS (007)	

(1) NAME AND INDIVIDUAL IDENTIFYING NUMBER (e.g., LAST FOUR DIGITS OF SOCIAL SECURITY NUMBER) OF WORKER	(2) NO. OF WITHHOLDING EXEMPTIONS	(3) WORK CLASSIFICATION	DT. OR ST.	(4) DAY AND DATE							(5) TOTAL HOURS	(6) RATE OF PAY	(7) GROSS AMOUNT EARNED	(8) DEDUCTIONS				(9) NET WAGES PAID FOR WEEK	
				M	T	W	TH	F	SA	SU				FICA	WITH- HOLDING TAX	OTHER	TOTAL DEDUCTIONS		
				26	27	28	29	30	31	1									
HOURS WORKED EACH DAY																			
			O																
			S																
			O																
			S																
			O																
			S																
			O																
			S																
			O																
			S																
			O																
			S																
			O																
			S																

*Recd by: [Signature] 2/10/15*

While completion of Form WH-347 is optional, it is mandatory for covered contractors and subcontractors performing work on Federally financed or assisted construction contracts to respond to the information collection contained in 29 C.F.R. §§ 3.3, 5.5(a). The Copeland Act (40 U.S.C. § 3145) contractors and subcontractors performing work on Federally financed or assisted construction contracts to "furnish weekly a statement with respect to the wages paid each employee during the preceding week." U.S. Department of Labor (DOL) regulations at 29 C.F.R. § 5.5(a)(3)(ii) require contractors to submit weekly a copy of all payrolls to the Federal agency contracting for or financing the construction project, accompanied by a signed "Statement of Compliance" indicating that the payrolls are correct and complete and that each laborer or mechanic has been paid not less than the proper Davis-Bacon prevailing wage rate for the work performed. DOL and federal contracting agencies receiving this information review the information to determine that employees have received legally required wages and fringe benefits.

Public Burden Statement

We estimate that it will take an average of 55 minutes to complete this collection, including time for reviewing instructions, searching existing data sources, gathering and maintaining the data needed, and completing and reviewing the collection of information. If you have any comments regarding these estimates or any other aspect of this collection, including suggestions for reducing this burden, send them to the Administrator, Wage and Hour Division, U.S. Department of Labor, Room S3502, 200 Constitution Avenue, N.W., Washington, D.C. 20210









Date 02/10/2015

I, HYON SANG KIM OPERATIONS MANAGER  
(Name of Signatory Party) (Title)

do hereby state:

(1) That I pay or supervise the payment of the persons employed by

KORANDO CORPORATION on the  
(Contractor or Subcontractor)  
380H Harmon Industrial Park, Tamuning, GU; that during the payroll period commencing on the  
(Building or Work)

02 day of February, 2015, and ending the 08 day of February, 2015

all persons employed on said project have been paid the full weekly wages earned, that no rebates have been or will be made either directly or indirectly to or on behalf of said

KORANDO CORPORATION from the full  
(Contractor or Subcontractor)

weekly wages earned by any person and that no deductions have been made either directly or indirectly from the full wages earned by any person, other than permissible deductions as defined in Regulations, Part 3 (29 C.F.R. Subtitle A), issued by the Secretary of Labor under the Copeland Act, as amended (48 Stat. 948, 63 Stat. 108, 72 Stat. 957; 76 Stat. 357; 40 U.S.C. § 3145), and described below.

\_\_\_\_\_  
\_\_\_\_\_  
\_\_\_\_\_

(2) That any payrolls otherwise under this contract required to be submitted for the above period are correct and complete; that the wage rates for laborers or mechanics contained therein are not less than the applicable wage rates contained in any wage determination incorporated into the contract; that the classifications set forth therein for each laborer or mechanic conform with the work he performed.

(3) That any apprentices employed in the above period are duly registered in a bona fide apprenticeship program registered with a State apprenticeship agency recognized by the Bureau of Apprenticeship and Training, United States Department of Labor, or if no such recognized agency exists in a State, are registered with the Bureau of Apprenticeship and Training, United States Department of Labor.

(4) That

(a) WHERE FRINGE BENEFITS ARE PAID TO APPROVED PLANS, FUNDS, OR PROGRAMS

- in addition to the basic hourly wage rates paid to each laborer or mechanic listed in the above referenced payroll, payments of fringe benefits as listed in the contract have been or will be made to appropriate programs for the benefit of such employees, except as noted in section 4(c) below.

(b) WHERE FRINGE BENEFITS ARE PAID IN CASH

- Each laborer or mechanic listed in the above referenced payroll has been paid, as indicated on the payroll, an amount not less than the sum of the applicable basic hourly wage rate plus the amount of the required fringe benefits as listed in the contract, except as noted in section 4(c) below.

(c) EXCEPTIONS

EXCEPTION (CRAFT)	EXPLANATION

REMARKS:

NO ACTIVITY

NAME AND TITLE Hyon Sang Kim / Operations Manager	SIGNATURE 
THE WILLFUL FALSIFICATION OF ANY OF THE ABOVE STATEMENTS MAY SUBJECT THE CONTRACTOR OR SUBCONTRACTOR TO CIVIL OR CRIMINAL PROSECUTION. SEE SECTION 1001 OF TITLE 18 AND SECTION 231 OF TITLE 31 OF THE UNITED STATES CODE.	



PAYROLL

(For Contractor's Optional Use; See Instructions at [www.dol.gov/whd/forms/wh347instr.htm](http://www.dol.gov/whd/forms/wh347instr.htm))



Persons are not required to respond to the collection of information unless it displays a currently valid OMB control number.

NAME OF CONTRACTOR  OR SUBCONTRACTOR   
 KORANDO CORPORATION  
 ADDRESS P.O. BOX 20538  
 BARRIGADA, GUAM 96921  
 OMB No.: 1235-0008  
 Expires: 01/31/2015

PAYROLL NO. 6 FOR WEEK ENDING 02/15/2015  
 PROJECT AND LOCATION Bile/Pigua Bridge Replacement (Construction Phase)  
 Along Route 4, Merizo, Guam  
 PROJECT OR CONTRACT NO. GU-NH-NBIS (007)

(1) NAME AND INDIVIDUAL IDENTIFYING NUMBER (e.g., LAST FOUR DIGITS OF SOCIAL SECURITY NUMBER) OF WORKER	(2) NO. OF WITH-HOLDING EXEMPTIONS	(3) WORK CLASSIFICATION	(4) DAY AND DATE							(5) TOTAL HOURS	(6) RATE OF PAY	(7) GROSS AMOUNT EARNED	(8) DEDUCTIONS					(9) NET WAGES PAID FOR WEEK	
			DT. OR ST.	M	T	W	TH	F	SA				SU	FICA	WITH- HOLDING TAX	OTHER	TOTAL DEDUCTIONS		
				9	10	11	12	13	14				15						HOURS WORKED EACH DAY
NO WORK PERFORMANCE			O																
			S																
			O																
			S																
			O																
			S																
			O																
			S																
			O																
			S																
			O																
			S																

*[Handwritten Signature]*  
2/24/2015

While completion of Form WH-347 is optional, it is mandatory for covered contractors and subcontractors performing work on Federally financed or assisted construction contracts to respond to the information collection contained in 29 C.F.R. §§ 3.3, 5.5(a). The Copeland Act (40 U.S.C. § 3145) contractors and subcontractors performing work on Federally financed or assisted construction contracts to "furnish weekly a statement with respect to the wages paid each employee during the preceding week." U.S. Department of Labor (DOL) regulations at 29 C.F.R. § 5.5(a)(3)(ii) require contractors to submit weekly a copy of all payrolls to the Federal agency contracting for or financing the construction project, accompanied by a signed "Statement of Compliance" indicating that the payrolls are correct and complete and that each laborer or mechanic has been paid not less than the proper Davis-Bacon prevailing wage rate for the work performed. DOL and federal contracting agencies receiving this information review the information to determine that employees have received legally required wages and fringe benefits.

Public Burden Statement

We estimate that it will take an average of 55 minutes to complete this collection, including time for reviewing instructions, searching existing data sources, gathering and maintaining the data needed, and completing and reviewing the collection of information. If you have any comments regarding these estimates or any other aspect of this collection, including suggestions for reducing this burden, send them to the Administrator, Wage and Hour Division, U.S. Department of Labor, Room S3502, 200 Constitution Avenue, N.W. Washington, D.C. 20210

Date 02/17/2015

I, HYON SANG KIM OPERATIONS MANAGER  
(Name of Signatory Party) (Title)

do hereby state:

(1) That I pay or supervise the payment of the persons employed by

KORANDO CORPORATION

(Contractor or Subcontractor) on the

380H Harmon Industrial Park, Tamuning, GU; that during the payroll period commencing on the  
(Building or Work)

09 day of February, 2015, and ending the 15 day of February, 2015.

all persons employed on said project have been paid the full weekly wages earned, that no rebates have been or will be made either directly or indirectly to or on behalf of said

KORANDO CORPORATION

from the full

(Contractor or Subcontractor)

weekly wages earned by any person and that no deductions have been made either directly or indirectly from the full wages earned by any person, other than permissible deductions as defined in Regulations, Part 3 (29 C.F.R. Subtitle A), issued by the Secretary of Labor under the Copeland Act, as amended (48 Stat. 948, 63 Stat. 108, 72 Stat. 967; 76 Stat. 357; 40 U.S.C. § 3145), and described below:

\_\_\_\_\_  
\_\_\_\_\_  
\_\_\_\_\_

(2) That any payrolls otherwise under this contract required to be submitted for the above period are correct and complete; that the wage rates for laborers or mechanics contained therein are not less than the applicable wage rates contained in any wage determination incorporated into the contract; that the classifications set forth therein for each laborer or mechanic conform with the work he performed.

(3) That any apprentices employed in the above period are duly registered in a bona fide apprenticeship program registered with a State apprenticeship agency recognized by the Bureau of Apprenticeship and Training, United States Department of Labor, or if no such recognized agency exists in a State, are registered with the Bureau of Apprenticeship and Training, United States Department of Labor.

(4) That

(a) WHERE FRINGE BENEFITS ARE PAID TO APPROVED PLANS, FUNDS, OR PROGRAMS

- in addition to the basic hourly wage rates paid to each laborer or mechanic listed in the above referenced payroll, payments of fringe benefits as listed in the contract have been or will be made to appropriate programs for the benefit of such employees, except as noted in section 4(c) below.

(b) WHERE FRINGE BENEFITS ARE PAID IN CASH

- Each laborer or mechanic listed in the above referenced payroll has been paid, as indicated on the payroll, an amount not less than the sum of the applicable basic hourly wage rate plus the amount of the required fringe benefits as listed in the contract, except as noted in section 4(c) below.

(c) EXCEPTIONS

EXCEPTION (CRAFT)	EXPLANATION

REMARKS:

NO ACTIVITY

NAME AND TITLE

Hyon Sang Kim / Operations Manager

SIGNATURE

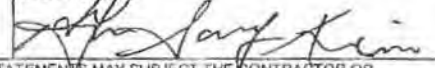

THE WILLFUL FALSIFICATION OF ANY OF THE ABOVE STATEMENTS MAY SUBJECT THE CONTRACTOR OR SUBCONTRACTOR TO CIVIL OR CRIMINAL PROSECUTION. SEE SECTION 1001 OF TITLE 18 AND SECTION 231 OF TITLE 31 OF THE UNITED STATES CODE.







Date 02/23/2015

I, HYON SANG KIM OPERATIONS MANAGER  
(Name of Signatory Party) (Title)

do hereby state:

(1) That I pay or supervise the payment of the persons employed by

KORANDO CORPORATION

(Contractor or Subcontractor)

on the

380H Harmon Industrial Park, Tamuning, GU; that during the payroll period commencing on the  
(Building or Work)

16 day of February, 2015, and ending the 22 day of February, 2015.

all persons employed on said project have been paid the full weekly wages earned, that no rebates have been or will be made either directly or indirectly to or on behalf of said

KORANDO CORPORATION

(Contractor or Subcontractor)

from the full

weekly wages earned by any person and that no deductions have been made either directly or indirectly from the full wages earned by any person, other than permissible deductions as defined in Regulations, Part 3 (29 C.F.R. Subtitle A), issued by the Secretary of Labor under the Copeland Act, as amended (48 Stat. 948, 63 Stat. 108, 72 Stat. 967; 76 Stat. 357; 40 U.S.C. § 3145), and described below:

\_\_\_\_\_  
\_\_\_\_\_  
\_\_\_\_\_

(2) That any payrolls otherwise under this contract required to be submitted for the above period are correct and complete; that the wage rates for laborers or mechanics contained therein are not less than the applicable wage rates contained in any wage determination incorporated into the contract; that the classifications set forth therein for each laborer or mechanic conform with the work he performed.

(3) That any apprentices employed in the above period are duly registered in a bona fide apprenticeship program registered with a State apprenticeship agency recognized by the Bureau of Apprenticeship and Training, United States Department of Labor, or if no such recognized agency exists in a State, are registered with the Bureau of Apprenticeship and Training, United States Department of Labor.

(4) That:

(a) WHERE FRINGE BENEFITS ARE PAID TO APPROVED PLANS, FUNDS, OR PROGRAMS

in addition to the basic hourly wage rates paid to each laborer or mechanic listed in the above referenced payroll, payments of fringe benefits as listed in the contract have been or will be made to appropriate programs for the benefit of such employees, except as noted in section 4(c) below.

(b) WHERE FRINGE BENEFITS ARE PAID IN CASH

Each laborer or mechanic listed in the above referenced payroll has been paid, as indicated on the payroll, an amount not less than the sum of the applicable basic hourly wage rate plus the amount of the required fringe benefits as listed in the contract, except as noted in section 4(c) below.

(c) EXCEPTIONS

EXCEPTION (CRAFT)	EXPLANATION

REMARKS:

NO ACTIVITY

NAME AND TITLE

Hyon Sang Kim / Operations Manager

SIGNATURE

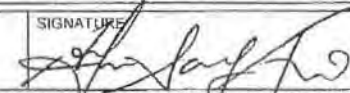

THE WILLFUL FALSIFICATION OF ANY OF THE ABOVE STATEMENTS MAY SUBJECT THE CONTRACTOR OR SUBCONTRACTOR TO CIVIL OR CRIMINAL PROSECUTION, SEE SECTION 1001 OF TITLE 18 AND SECTION 231 OF TITLE 31 OF THE UNITED STATES CODE.

PAYROLL

(For Contractor's Optional Use; See Instructions at [www.dol.gov/whd/forms/wh347instr.htm](http://www.dol.gov/whd/forms/wh347instr.htm))



Persons are not required to respond to the collection of information unless it displays a currently valid OMB control number.

NAME OF CONTRACTOR <input checked="" type="checkbox"/> OR SUBCONTRACTOR <input type="checkbox"/>		ADDRESS	OMB No.: 1235-0008 Expires: 01/31/2015
KORANDO CORPORATION		P.O. BOX 20538 BARRIGADA, GUAM 96921	
PAYROLL NO. 8	FOR WEEK ENDING 03/01/2015	PROJECT AND LOCATION Bile/Pigua Bridge Replacement (Construction Phase) Along Route 4, Merizo, Guam	PROJECT OR CONTRACT NO. GU-NH-NBIS (007)

(1) NAME AND INDIVIDUAL IDENTIFYING NUMBER (e.g., LAST FOUR DIGITS OF SOCIAL SECURITY NUMBER) OF WORKER	(2) NO. OF WITHHOLDING EXEMPTIONS	(3) WORK CLASSIFICATION	(4) DAY AND DATE							(5) TOTAL HOURS	(6) RATE OF PAY	(7) GROSS AMOUNT EARNED	(8) DEDUCTIONS				(9) NET WAGES PAID FOR WEEK
			M	T	W	TH	F	SA	SU				FICA	WITH- HOLDING TAX	OTHER	TOTAL DEDUCTIONS	
			23	24	25	26	27	28	1				HOURS WORKED EACH DAY				
NO WORK PERFORMANCE																	

*[Handwritten Signature]*

3-10-15

**RECEIVED**

While completion of Form WH-347 is optional, it is mandatory for covered contractors and subcontractors performing work on Federally financed or assisted construction contracts to respond to the information collection contained in 29 C.F.R. §§ 3.3, 5.5(a). The Copeland Act (40 U.S.C. § 3145) contractors and subcontractors performing work on Federally financed or assisted construction contracts to "furnish weekly a statement with respect to the wages paid each employee during the preceding week." U.S. Department of Labor (DOL) regulations at 29 C.F.R. § 5.5(a)(3)(ii) require contractors to submit weekly a copy of all payrolls to the Federal agency contracting for or financing the construction project, accompanied by a signed "Statement of Compliance" indicating that the payrolls are correct and complete and that each laborer or mechanic has been paid not less than the proper Davis-Bacon prevailing wage rate for the work performed. DOL and federal contracting agencies receiving this information review the information to determine that employees have received legally required wages and fringe benefits.

Public Burden Statement

We estimate that it will take an average of 65 minutes to complete this collection, including time for reviewing instructions, searching existing data sources, gathering and maintaining the data needed, and completing and reviewing the collection of information. If you have any comments regarding these estimates or any other aspect of this collection, including suggestions for reducing this burden, send them to the Administrator, Wage and Hour Division, U.S. Department of Labor, Room 53502, 200 Constitution Avenue, N.W. Washington, D.C. 20210



Date 03/02/2015

I, HYON SANG KIM OPERATIONS MANAGER  
(Name of Signatory Party) (Title)

do hereby state:

(1) That I pay or supervise the payment of the persons employed by

KORANDO CORPORATION on the  
(Contractor or Subcontractor)

380H Harmon Industrial Park, Tamuning, GU; that during the payroll period commencing on the  
(Building or Work)

23 day of February, 2015, and ending the 01 day of March, 2015

all persons employed on said project have been paid the full weekly wages earned, that no rebates have been or will be made either directly or indirectly to or on behalf of said

KORANDO CORPORATION from the full  
(Contractor or Subcontractor)

weekly wages earned by any person and that no deductions have been made either directly or indirectly from the full wages earned by any person, other than permissible deductions as defined in Regulations, Part 3 (29 C.F.R. Subtitle A), issued by the Secretary of Labor under the Copeland Act, as amended (48 Stat. 948, 63 Stat. 108, 72 Stat. 967; 76 Stat. 357; 40 U.S.C. § 3145), and described below.

\_\_\_\_\_  
\_\_\_\_\_  
\_\_\_\_\_

(2) That any payrolls otherwise under this contract required to be submitted for the above period are correct and complete; that the wage rates for laborers or mechanics contained therein are not less than the applicable wage rates contained in any wage determination incorporated into the contract; that the classifications set forth therein for each laborer or mechanic conform with the work he performed.

(3) That any apprentices employed in the above period are duly registered in a bona fide apprenticeship program registered with a State apprenticeship agency recognized by the Bureau of Apprenticeship and Training, United States Department of Labor, or if no such recognized agency exists in a State, are registered with the Bureau of Apprenticeship and Training, United States Department of Labor.

(4) That:

(a) WHERE FRINGE BENEFITS ARE PAID TO APPROVED PLANS, FUNDS, OR PROGRAMS

— in addition to the basic hourly wage rates paid to each laborer or mechanic listed in the above referenced payroll, payments of fringe benefits as listed in the contract have been or will be made to appropriate programs for the benefit of such employees, except as noted in section 4(c) below.

(b) WHERE FRINGE BENEFITS ARE PAID IN CASH

— Each laborer or mechanic listed in the above referenced payroll has been paid, as indicated on the payroll, an amount not less than the sum of the applicable basic hourly wage rate plus the amount of the required fringe benefits as listed in the contract, except as noted in section 4(c) below.

(c) EXCEPTIONS

EXCEPTION (CRAFT)	EXPLANATION

REMARKS:

NO ACTIVITY

NAME AND TITLE

Hyon Sang Kim / Operations Manager

SIGNATURE

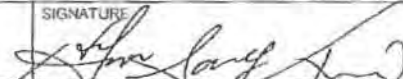

THE WILLFUL FALSIFICATION OF ANY OF THE ABOVE STATEMENTS MAY SUBJECT THE CONTRACTOR OR SUBCONTRACTOR TO CIVIL OR CRIMINAL PROSECUTION. SEE SECTION 1001 OF TITLE 18 AND SECTION 231 OF TITLE 31 OF THE UNITED STATES CODE.



PAYROLL

(For Contractor's Optional Use; See Instructions at [www.dol.gov/whd/forms/wh347instr.htm](http://www.dol.gov/whd/forms/wh347instr.htm))



Persons are not required to respond to the collection of information unless it displays a currently valid OMB control number.

NAME OF CONTRACTOR  OR SUBCONTRACTOR   
 KORANDO CORPORATION  
 ADDRESS P.O. BOX 20538  
 BARRIGADA, GUAM 96921  
 OMB No.: 1235-0008  
 Expires: 01/31/2015

PAYROLL NO. 9 FOR WEEK ENDING 03/08/2015  
 PROJECT AND LOCATION Bile/Pigua Bridge Replacement (Construction Phase)  
 Along Route 4, Merizo, Guam  
 PROJECT OR CONTRACT NO. GU-NH-NBIS (007)

(1) NAME AND INDIVIDUAL IDENTIFYING NUMBER (e.g., LAST FOUR DIGITS OF SOCIAL SECURITY NUMBER) OF WORKER	(2) NO. OF WITHHOLDING EXEMPTIONS	(3) WORK CLASSIFICATION	OT. OR AT.	(4) DAY AND DATE							(5) TOTAL HOURS	(6) RATE OF PAY	(7) GROSS AMOUNT EARNED	(8) DEDUCTIONS					(9) NET WAGES PAID FOR WEEK
				M	T	W	TH	F	SA	SU				FICA	WITH- HOLDING TAX	OTHER	TOTAL DEDUCTIONS		
				1	2	3	4	5	6	7								8	
NO WORK PERFORMANCE			O																
			S																
			O																
			S																
			O																
			S																
			O																
			S																
			O																
			S																

*[Handwritten Signature]*  
 3-10-15  
**RECEIVED**

While completion of Form WH-347 is optional, it is mandatory for covered contractors and subcontractors performing work on Federally financed or assisted construction contracts to respond to the information collection contained in 29 C.F.R. § 5.5(a). The Copeland Act (40 U.S.C. § 3145) contractors and subcontractors performing work on Federally financed or assisted construction contracts to "furnish weekly a statement with respect to the wages paid each employee during the preceding week." U.S. Department of Labor (DOL) regulations at 29 C.F.R. § 5.5(a)(3)(ii) require contractors to submit weekly a copy of all payrolls to the Federal agency contracting for or financing the construction project, accompanied by a signed "Statement of Compliance" indicating that the payrolls are correct and complete and that each laborer or mechanic has been paid not less than the proper Davis-Bacon prevailing wage rate for the work performed. DOL and federal contracting agencies receiving this information review the information to determine that employees have received legally required wages and fringe benefits.

Public Burden Statement

We estimate that it will take an average of 55 minutes to complete this collection, including time for reviewing instructions, searching existing data sources, gathering and maintaining the data needed, and completing and reviewing the collection of information. If you have any comments regarding these estimates or any other aspect of this collection, including suggestions for reducing this burden, send them to the Administrator, Wage and Hour Division, U.S. Department of Labor, Room S3502, 200 Constitution Avenue, N.W. Washington, D.C. 20210

Date 03/09/2015

I, HYON SANG KIM OPERATIONS MANAGER  
(Name of Signatory Party) (Title)

do hereby state:

(1) That I pay or supervise the payment of the persons employed by

KORANDO CORPORATION on the  
(Contractor or Subcontractor)  
380H Harmon Industrial Park, Tamuning, GU; that during the payroll period commencing on the  
(Building or Work)

02 day of March, 2015, and ending the 08 day of March, 2015.

all persons employed on said project have been paid the full weekly wages earned, that no rebates have been or will be made either directly or indirectly to or on behalf of said

KORANDO CORPORATION from the full  
(Contractor or Subcontractor)

weekly wages earned by any person and that no deductions have been made either directly or indirectly from the full wages earned by any person, other than permissible deductions as defined in Regulations, Part 3 (29 C.F.R. Subtitle A), issued by the Secretary of Labor under the Copeland Act, as amended (48 Stat. 946, 63 Stat. 108, 72 Stat. 967; 76 Stat. 357; 40 U.S.C. § 3145), and described below.

\_\_\_\_\_  
\_\_\_\_\_  
\_\_\_\_\_

(2) That any payrolls otherwise under this contract required to be submitted for the above period are correct and complete; that the wage rates for laborers or mechanics contained therein are not less than the applicable wage rates contained in any wage determination incorporated into the contract; that the classifications set forth therein for each laborer or mechanic conform with the work he performed.

(3) That any apprentices employed in the above period are duly registered in a bona fide apprenticeship program registered with a State apprenticeship agency recognized by the Bureau of Apprenticeship and Training, United States Department of Labor, or if no such recognized agency exists in a State, are registered with the Bureau of Apprenticeship and Training, United States Department of Labor.

(4) That:  
(a) WHERE FRINGE BENEFITS ARE PAID TO APPROVED PLANS, FUNDS, OR PROGRAMS

- in addition to the basic hourly wage rates paid to each laborer or mechanic listed in the above referenced payroll, payments of fringe benefits as listed in the contract have been or will be made to appropriate programs for the benefit of such employees, except as noted in section 4(c) below.

(b) WHERE FRINGE BENEFITS ARE PAID IN CASH

- Each laborer or mechanic listed in the above referenced payroll has been paid, as indicated on the payroll, an amount not less than the sum of the applicable basic hourly wage rate plus the amount of the required fringe benefits as listed in the contract, except as noted in section 4(c) below.

(c) EXCEPTIONS

EXCEPTION (CRAFT)	EXPLANATION

REMARKS:

NO ACTIVITY

NAME AND TITLE  
Hyon Sang Kim / Operations Manager

SIGNATURE



THE WILLFUL FALSIFICATION OF ANY OF THE ABOVE STATEMENTS MAY SUBJECT THE CONTRACTOR OR SUBCONTRACTOR TO CIVIL OR CRIMINAL PROSECUTION. SEE SECTION 1001 OF TITLE 18 AND SECTION 231 OF TITLE 31 OF THE UNITED STATES CODE.

PAYROLL

(For Contractor's Optional Use; See Instructions at [www.dol.gov/whd/forms/wh347instr.htm](http://www.dol.gov/whd/forms/wh347instr.htm))

Persons are not required to respond to the collection of information unless it displays a currently valid OMB control number.



U.S. Wage and Hour Division

Rev. Dec. 2008

NAME OF CONTRACTOR <input checked="" type="checkbox"/> OR SUBCONTRACTOR <input type="checkbox"/>		ADDRESS		OMB No.: 1235-0008	
KORANDO CORPORATION		P.O. BOX 20538 BARRIGADA, GUAM 96921		Expires: 01/31/2015	
PAYROLL NO. 10	FOR WEEK ENDING 03/15/2015	PROJECT AND LOCATION Bile/Pigua Bridge Replacement (Construction Phase) Along Route 4, Merizo, Guam		PROJECT OR CONTRACT NO. GU-NH-NBIS (007)	

(1) NAME AND INDIVIDUAL IDENTIFYING NUMBER (e.g., LAST FOUR DIGITS OF SOCIAL SECURITY NUMBER) OF WORKER	(2) NO. OF HOURS EXEMPTIONS	(3) WORK CLASSIFICATION	(4) DAY AND DATE							(5) TOTAL HOURS	(6) RATE OF PAY	(7) GROSS AMOUNT EARNED	(8) DEDUCTIONS				(9) NET WAGES PAID FOR WEEK	
			OT. DIS. ST.	M	T	W	TH	F	SA				SU	FICA	WITH- HOLDING TAX	OTHER		TOTAL DEDUCTIONS
				9	10	11	12	13	14				15					
NO WORK PERFORMANCE																		

*[Handwritten signature]*  
3-17-15

While completion of Form WH-347 is optional, it is mandatory for covered contractors and subcontractors performing work on Federally financed or assisted construction contracts to respond to the information collection contained in 29 C.F.R. §§ 3.3, 6.6(a). The Copeland Act (40 U.S.C. § 3145) contractors and subcontractors performing work on Federally financed or assisted construction contracts to "furnish weekly a statement with respect to the wages paid each employee during the preceding week." U.S. Department of Labor (DOL) regulations at 29 C.F.R. § 5.5(a)(3)(ii) require contractors to submit weekly a copy of all payrolls to the Federal agency contracting for or financing the construction project, accompanied by a signed "Statement of Compliance" indicating that the payrolls are correct and complete and that each laborer or mechanic has been paid not less than the proper Davis-Bacon prevailing wage rate for the work performed. DOL and federal contracting agencies receiving this information review the information to determine that employees have received legally required wages and fringe benefits.

Public Burden Statement

We estimate that it will take an average of 55 minutes to complete this collection, including time for reviewing instructions, searching existing data sources, gathering and maintaining the data needed, and completing and reviewing the collection of information. If you have any comments regarding these estimates or any other aspect of this collection, including suggestions for reducing this burden, send them to the Administrator, Wage and Hour Division, U.S. Department of Labor, Room 53502, 200 Constitution Avenue, N.W., Washington, D.C. 20210



Date 03/17/2015

I, HYON SANG KIM OPERATIONS MANAGER  
(Name of Signatory Party) (Title)

do hereby state:

(1) That I pay or supervise the payment of the persons employed by

KORANDO CORPORATION

(Contractor or Subcontractor)

on the

380H Harmon Industrial Park, Tamuning, GU; that during the payroll period commencing on the  
(Building or Work)

09 day of March, 2015, and ending the 15 day of March, 2015

all persons employed on said project have been paid the full weekly wages earned, that no rebates have been or will be made either directly or indirectly to or on behalf of said

KORANDO CORPORATION

(Contractor or Subcontractor)

from the full

weekly wages earned by any person and that no deductions have been made either directly or indirectly from the full wages earned by any person, other than permissible deductions as defined in Regulations, Part 3 (29 C.F.R. Subtitle A), issued by the Secretary of Labor under the Copeland Act, as amended (48 Stat. 948, 63 Stat. 108, 72 Stat. 967; 76 Stat. 357; 40 U.S.C. § 3145), and described below.

\_\_\_\_\_  
\_\_\_\_\_  
\_\_\_\_\_

(2) That any payrolls otherwise under this contract required to be submitted for the above period are correct and complete; that the wage rates for laborers or mechanics contained therein are not less than the applicable wage rates contained in any wage determination incorporated into the contract; that the classifications set forth therein for each laborer or mechanic conform with the work he performed.

(3) That any apprentices employed in the above period are duly registered in a bona fide apprenticeship program registered with a State apprenticeship agency recognized by the Bureau of Apprenticeship and Training, United States Department of Labor, or if no such recognized agency exists in a State, are registered with the Bureau of Apprenticeship and Training, United States Department of Labor.

(4) That:

(a) WHERE FRINGE BENEFITS ARE PAID TO APPROVED PLANS, FUNDS, OR PROGRAMS

— in addition to the basic hourly wage rates paid to each laborer or mechanic listed in the above referenced payroll, payments of fringe benefits as listed in the contract have been or will be made to appropriate programs for the benefit of such employees, except as noted in section 4(c) below.

(b) WHERE FRINGE BENEFITS ARE PAID IN CASH

— Each laborer or mechanic listed in the above referenced payroll has been paid, as indicated on the payroll, an amount not less than the sum of the applicable basic hourly wage rate plus the amount of the required fringe benefits as listed in the contract, except as noted in section 4(c) below.

(c) EXCEPTIONS

EXCEPTION (CRAFT)	EXPLANATION

REMARKS:

NO ACTIVITY

NAME AND TITLE

Hyon Sang Kim / Operations Manager

SIGNATURE

THE WILLFUL FALSIFICATION OF ANY OF THE ABOVE STATEMENTS MAY SUBJECT THE CONTRACTOR OR SUBCONTRACTOR TO CIVIL OR CRIMINAL PROSECUTION. SEE SECTION 1001 OF TITLE 18 AND SECTION 231 OF TITLE 31 OF THE UNITED STATES CODE.



**KORANDO CORPORATION**  
**GENERAL CONTRACTOR**  
PO BOX 20538 GMF, GUAM 96921  
Tel Nos. (671) 649-7880/81 Fax (671) 649-7882

COPY

**BILE / PIGUA BRIDGE REPLACEMENT  
(CONSTRUCTION PHASE)  
PROJECT NO.: GU-NH-NBIS (007)**

**CERTIFIED PAYROLL REPORTS  
FOR WEEK ENDING 03-22-2015**

	
Stanley Consultants Inc.	
 Signature	4/28/2015 Date

PAYROLL

(For Contractor's Optional Use; See Instructions at [www.dol.gov/whd/forms/wh347instr.htm](http://www.dol.gov/whd/forms/wh347instr.htm))



Persons are not required to respond to the collection of information unless it displays a currently valid OMB control number.

Rev. Dec. 2008

NAME OF CONTRACTOR <input checked="" type="checkbox"/> OR SUBCONTRACTOR <input type="checkbox"/>		ADDRESS		OMB No.: 1235-0008	
KORANDO CORPORATION		P.O. BOX 20538 BARRIGADA, GUAM 96921		Expires: 01/31/2015	
PAYROLL NO. 11	FOR WEEK ENDING 03/22/2015	PROJECT AND LOCATION Bite/Pigua Bridge Replacement (Construction Phase) Along Route 4, Merizo, Guam		PROJECT OR CONTRACT NO. GU-NH-NBIS (007)	

(1) NAME AND INDIVIDUAL IDENTIFYING NUMBER (e.g., LAST FOUR DIGITS OF SOCIAL SECURITY NUMBER) OF WORKER	(2) NO. OF WITHHOLDING EXEMPTIONS	(3) WORK CLASSIFICATION	(4) DAY AND DATE							(5) TOTAL HOURS	(6) RATE OF PAY	(7) GROSS AMOUNT EARNED	(8) DEDUCTIONS					(9) NET WAGES PAID FOR WEEK
			M	T	W	TH	F	SA	SU				FICA	WITH- HOLDING TAX	B/L	OTHER	TOTAL DEDUCTIONS	
Javelosa, Lauro E. P.O. Box 20538 Barrigada, Guam 96921 5139 S	1	Construction Laborer	O	0.00	0.00	0.00	0.00	0.00	0.00	0.00		\$205.92						
			S	0.00	0.00	0.00	0.00	0.00	0.00	0.00	16.00	12.87	\$489.06	\$37.41	\$46.00	\$35.00		\$118.41
Leg, Kerman P.O. Box 20538 Barrigada, Guam 96921 2346 M	1	Construction Laborer	O	0.00	0.00	0.00	0.00	0.00	0.00	0.00		\$68.00						
			S	0.00	0.00	0.00	0.00	0.00	0.00	0.00	8.00	8.50	\$136.00	\$10.40	\$0.00	\$0.00		\$10.40
Luzama, Petrus P.O. Box 20538 Barrigada, Guam 96921 9803 S	5	Construction Laborer	O	0.00	0.00	0.00	0.00	0.00	0.00	0.00		\$136.00						
			S	0.00	0.00	0.00	0.00	0.00	0.00	0.00	16.00	8.50	\$212.50	\$16.26	\$0.00	\$0.00		\$16.26
			O															
			S															
			O															
			S															
			O															
			S															
			O															
			S															

While completion of Form WH-347 is optional, it is mandatory for covered contractors and subcontractors performing work on Federally financed or assisted construction contracts to respond to the information collection contained in 29 C.F.R. §§ 3.3, 5.5(a). The Copeland Act (40 U.S.C. § 3145) contractors and subcontractors performing work on Federally financed or assisted construction contracts to "furnish weekly a statement with respect to the wages paid each employee during the preceding week." U.S. Department of Labor (DOL) regulations at 29 C.F.R. § 5.5(a)(3)(ii) require contractors to submit weekly a copy of all payrolls to the Federal agency contracting for or financing the construction project, accompanied by a signed "Statement of Compliance" indicating that the payrolls are correct and complete and that each laborer or mechanic has been paid not less than the proper Davis-Bacon prevailing wage rate for the work performed. DOL and federal contracting agencies receiving this information review the information to determine that employees have received legally required wages and fringe benefits.

Public Burden Statement

We estimate that it will take an average of 65 minutes to complete this collection, including time for reviewing instructions, searching existing data sources, gathering and maintaining the data needed, and completing and reviewing the collection of information. If you have any comments regarding these estimates or any other aspect of this collection, including suggestions for reducing this burden, send them to the Administrator, Wage and Hour Division, U.S. Department of Labor, Room S3502, 200 Constitution Avenue, N.W., Washington, D.C. 20210.







**KORANDO CORPORATION**  
**GENERAL CONTRACTOR**  
PO BOX 20538 GMF, GUAM 96921  
Tel Nos. (671) 649-7880/81 Fax (671) 649-7882

COPY

**BILE / PIGUA BRIDGE REPLACEMENT  
(CONSTRUCTION PHASE)  
PROJECT NO.: GU-NH-NBIS (007)**

**CERTIFIED PAYROLL REPORTS  
FOR WEEK ENDING 03-29-2015**



Stanley Consultants Inc.

*[Handwritten Signature]*  
Signature

4/28/2015  
Date

PAYROLL

(For Contractor's Optional Use; See Instructions at [www.dol.gov/whd/forms/wh347instr.htm](http://www.dol.gov/whd/forms/wh347instr.htm))

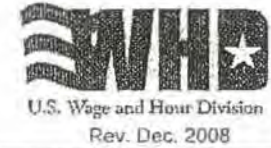

Persons are not required to respond to the collection of information unless it displays a currently valid OMB control number.

NAME OF CONTRACTOR <input checked="" type="checkbox"/> OR SUBCONTRACTOR <input type="checkbox"/>		ADDRESS		OMB No.: 1235-0008
KORANDO CORPORATION		P.O. BOX 20538 BARRIGADA, GUAM 96921		Expires: 01/31/2015
PAYROLL NO. 12	FOR WEEK ENDING 03/29/2015	PROJECT AND LOCATION Bile/Pigua Bridge Replacement (Construction Phase) Along Route 4, Merizo, Guam	PROJECT OR CONTRACT NO. GU-NH-NBIS (007)	

(1) NAME AND INDIVIDUAL IDENTIFYING NUMBER (e.g., LAST FOUR DIGITS OF SOCIAL SECURITY NUMBER) OF WORKER	(2) NO. OF WITHHOLDING EXEMPTIONS	(3) WORK CLASSIFICATION	Dist.	(4) DAY AND DATE							(5) TOTAL HOURS	(6) RATE OF PAY	(7) GROSS AMOUNT EARNED	(8) DEDUCTIONS					(9) NET WAGES PAID FOR WEEK	
				M	T	W	TH	F	SA	SU				FICA	WITH-HOLDING TAX	I/L	OTHER	TOTAL DEDUCTIONS		
				23	24	25	26	27	28	29				HOURS WORKED EACH DAY						
Javelosa, Lauro E. P.O. Box 20538 Barrigada, Guam 96921 5139 S	1	Construction Laborer	O	0.00	0.00	0.00	0.00	0.00	0.00	0.00	40.00	12.87	\$514.80	\$43.08	\$57.00	\$35.00	\$0.00	\$0.00	\$135.08	\$428.00
			S	0.00	0.00	0.00	0.00	0.00	0.00	0.00			\$563.08							
Leg, Kerman P.O. Box 20538 Barrigada, Guam 96921 2346 M	1	Construction Laborer	O	0.00	0.00	0.00	0.00	0.00	0.00	0.00	40.00	8.50	\$340.00	\$28.46	\$13.00	\$0.00	\$0.00	\$0.00	\$41.46	\$330.42
			S	0.00	0.00	0.00	0.00	0.00	0.00	0.00			\$371.88							
Luzama, Petrus P.O. Box 20538 Barrigada, Guam 96921 9803 S	5	Construction Laborer	O	0.00	0.00	0.00	0.00	0.00	0.00	0.00	8.50		\$0.00	\$0.00	\$0.00	\$0.00	\$0.00	\$0.00		
			S	0.00	0.00	0.00	0.00	0.00	0.00	0.00			\$0.00							
			O																	
			S																	
			O																	
			S																	
			O																	
			S																	
			O																	
			S																	

While completion of Form WH-347 is optional, it is mandatory for covered contractors and subcontractors performing work on Federally financed or assisted construction contracts to respond to the information collection contained in 29 C.F.R. §§ 3.3, 5.5(a). The Copeland Act (40 U.S.C. § 3145) contractors and subcontractors performing work on Federally financed or assisted construction contracts to "furnish weekly a statement with respect to the wages paid each employee during the preceding week." U.S. Department of Labor (DOL) regulations at 29 C.F.R. § 5.5(a)(3)(i) require contractors to submit weekly a copy of all payrolls to the Federal agency contracting for or financing the construction project, accompanied by a signed "Statement of Compliance" indicating that the payrolls are correct and complete and that each laborer or mechanic has been paid not less than the proper Davis-Bacon prevailing wage rate for the work performed. DOL and Federal contracting agencies receiving this information review the information to determine that employees have received legally required wages and fringe benefits.

Public Burden Statement

We estimate that it will take an average of 55 minutes to complete this collection, including time for reviewing instructions, searching existing data sources, gathering and maintaining the data needed, and completing and reviewing the collection of information. If you have any comments regarding these estimates or any other aspect of this collection, including suggestions for reducing this burden, send them to the Administrator, Wage and Hour Division, U.S. Department of Labor, Room 53502, 200 Constitution Avenue, N.W., Washington, D.C. 20210



Date 04/15/2015

I, HYON SANG KIM OPERATIONS MANAGER  
(Name of Signatory Party) (Title)

do hereby state:

(1) That I pay or supervise the payment of the persons employed by

KORANDO CORPORATION on the  
(Contractor or Subcontractor)

380H Harmon Industrial Park, Tamuning, GU that during the payroll period commencing on the  
(Building or Work)

23 day of March, 2015, and ending the 29 day of March, 2015

all persons employed on said project have been paid the full weekly wages earned, that no rebates have been or will be made either directly or indirectly to or on behalf of said

KORANDO CORPORATION from the full  
(Contractor or Subcontractor)

weekly wages earned by any person and that no deductions have been made either directly or indirectly from the full wages earned by any person, other than permissible deductions as defined in Regulations, Part 3 (29 C.F.R. Subtitle A), issued by the Secretary of Labor under the Copeland Act, as amended (48 Stat. 948, 63 Stat. 108, 72 Stat. 967; 76 Stat. 357; 40 U.S.C. § 3145), and described below:

\_\_\_\_\_  
\_\_\_\_\_  
\_\_\_\_\_

(2) That any payrolls otherwise under this contract required to be submitted for the above period are correct and complete; that the wage rates for laborers or mechanics contained therein are not less than the applicable wage rates contained in any wage determination incorporated into the contract; that the classifications set forth therein for each laborer or mechanic conform with the work he performed.

(3) That any apprentices employed in the above period are duly registered in a bona fide apprenticeship program registered with a State apprenticeship agency recognized by the Bureau of Apprenticeship and Training, United States Department of Labor, or if no such recognized agency exists in a State, are registered with the Bureau of Apprenticeship and Training, United States Department of Labor.

(4) That:

(a) WHERE FRINGE BENEFITS ARE PAID TO APPROVED PLANS, FUNDS, OR PROGRAMS

- in addition to the basic hourly wage rates paid to each laborer or mechanic listed in the above referenced payroll, payments of fringe benefits as listed in the contract have been or will be made to appropriate programs for the benefit of such employees, except as noted in section 4(c) below.

(b) WHERE FRINGE BENEFITS ARE PAID IN CASH

- Each laborer or mechanic listed in the above referenced payroll has been paid, as indicated on the payroll, an amount not less than the sum of the applicable basic hourly wage rate plus the amount of the required fringe benefits as listed in the contract, except as noted in section 4(c) below.

(c) EXCEPTIONS

EXCEPTION (CRAFT)	EXPLANATION

REMARKS:

NAME AND TITLE: Hyon Sang Kim / Operations Manager SIGNATURE: 

THE WILLFUL FALSIFICATION OF ANY OF THE ABOVE STATEMENTS MAY SUBJECT THE CONTRACTOR OR SUBCONTRACTOR TO CIVIL OR CRIMINAL PROSECUTION. SEE SECTION 1001 OF TITLE 18 AND SECTION 731 OF TITLE 31 OF THE UNITED STATES CODE.



**KORANDO CORPORATION**  
**GENERAL CONTRACTOR**  
PO BOX 20538 GMF, GUAM 96921  
Tel Nos. (671) 649-7880/81 Fax (671) 649-7882

COPY

**BILE / PIGUA BRIDGE REPLACEMENT  
(CONSTRUCTION PHASE)  
PROJECT NO.: GU-NH-NBIS (007)**

**CERTIFIED PAYROLL REPORTS**  
FOR WEEK ENDING 04-05-2015



Stanley Consultants Inc.

*[Handwritten Signature]*  
Signature

4-28-2015  
Date

PAYROLL

(For Contractor's Optional Use; See Instructions at [www.dol.gov/whd/forms/wh347instr.htm](http://www.dol.gov/whd/forms/wh347instr.htm))

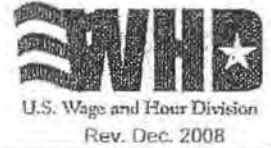

Persons are not required to respond to the collection of information unless it displays a currently valid OMB control number.

NAME OF CONTRACTOR <input checked="" type="checkbox"/> OR SUBCONTRACTOR <input type="checkbox"/>		ADDRESS	OMB No.: 1235-0008 Expires: 01/31/2015
KORANDO CORPORATION		P.O. BOX 20538 BARRIGADA, GUAM 96921	
PAYROLL NO. 13	FOR WEEK ENDING 04/05/2015	PROJECT AND LOCATION Bile/Pigua Bridge Replacement (Construction Phase) Along Route 4, Merizo, Guam	PROJECT OR CONTRACT NO. GU-NH-NBIS (007)

(1) NAME AND INDIVIDUAL IDENTIFYING NUMBER (e.g., LAST FOUR DIGITS OF SOCIAL SECURITY NUMBER) OF WORKER	(2) NO. OF WITHHOLDING EXEMPTIONS	(3) WORK CLASSIFICATION	OT CREDIT	(4) DAY AND DATE							(5) TOTAL HOURS	(6) RATE OF PAY	(7) GROSS AMOUNT EARNED	(8) DEDUCTIONS					(9) NET WAGES PAID FOR WEEK
				M	T	W	TH	F	SA	SU				FICA	WITH- HOLDING TAX	D/L	OTHER	TOTAL DEDUCTIONS	
				30	31	1	2	3	4	5									
Javelosa, Lauro E. P.O. Box 20538 Barrigada, Guam 96921 5139 S	1	Construction Laborer	O	0.00	0.00	0.00	0.00	0.00	0.00	0.00		\$437.58	\$42.33	\$56.00	\$35.00	\$0.00	\$0.00	\$133.33	\$420.09
				8.50	8.50	8.50	8.50	0.00	0.00	0.00	34.00	12.87							
Leg, Kerman P.O. Box 20538 Barrigada, Guam 96921 2346 M	1	Construction Laborer	O	0.00	0.00	0.00	0.00	0.00	0.00	0.00		\$216.75	\$16.58	\$0.00	\$0.00	\$0.00	\$0.00	\$16.58	\$200.17
				0.00	8.50	8.50	8.50	0.00	0.00	0.00	25.50	8.50							
Luzama, Petrus P.O. Box 20538 Barrigada, Guam 96921 9803 S	5	Construction Laborer	O	0.00	0.00	0.00	0.00	0.00	0.00	0.00			\$0.00	\$0.00	\$0.00	\$0.00	\$0.00	\$0.00	\$0.00
				0.00	0.00	0.00	0.00	0.00	0.00	0.00		8.50							

While completion of Form WH-347 is optional, it is mandatory for covered contractors and subcontractors performing work on Federally financed or assisted construction contracts to respond to the information collection contained in 29 C.F.R. §§ 3.3, 5.5(a). The Copeland Act (40 U.S.C. § 3145) contractors and subcontractors performing work on Federally financed or assisted construction contracts to "furnish weekly a statement with respect to the wages paid each employee during the preceding week." U.S. Department of Labor (DOL) regulations at 29 C.F.R. § 5.5(a)(3)(ii) require contractors to submit weekly a copy of all payrolls to the Federal agency contracting for or financing the construction project, accompanied by a signed "Statement of Compliance" indicating that the payrolls are correct and complete and that each laborer or mechanic has been paid not less than the proper Davis-Bacon prevailing wage rate for the work performed. DOL and federal contracting agencies receiving this information review the information to determine that employees have received legally required wages and fringe benefits.

Public Burden Statement

We estimate that it will take an average of 55 minutes to complete this collection, including time for reviewing instructions, searching existing data sources, gathering and maintaining the data needed, and completing and reviewing the collection of information. If you have any comments regarding these estimates or any other aspect of this collection, including suggestions for reducing this burden, send them to the Administrator, Wage and Hour Division, U.S. Department of Labor, Room S3502, 200 Constitution Avenue, N.W. Washington, D.C. 20210



Date 04/15/2015

I, HYON SANG KIM OPERATIONS MANAGER  
(Name of Signatory Party) (Title)

do hereby state:

(1) That I pay or supervise the payment of the persons employed by

KORANDO CORPORATION on the  
(Contractor or Subcontractor)  
380H Harmon Industrial Park, Tamuning, GU, that during the payroll period commencing on the  
(Building or Work)  
30 day of March, 2015, and ending the 05 day of April, 2015

all persons employed on said project have been paid the full weekly wages earned, that no rebates have been or will be made either directly or indirectly to or on behalf of said

KORANDO CORPORATION from the full  
(Contractor or Subcontractor)

weekly wages earned by any person and that no deductions have been made either directly or indirectly from the full wages earned by any person, other than permissible deductions as defined in Regulations, Part 3 (29 C.F.R. Subtitle A), issued by the Secretary of Labor under the Copeland Act, as amended (48 Stat. 948, 63 Stat. 108, 72 Stat. 967; 76 Stat. 357; 40 U.S.C. § 3145), and described below:

\_\_\_\_\_  
\_\_\_\_\_  
\_\_\_\_\_

(2) That any payrolls otherwise under this contract required to be submitted for the above period are correct and complete; that the wage rates for laborers or mechanics contained therein are not less than the applicable wage rates contained in any wage determination incorporated into the contract; that the classifications set forth therein for each laborer or mechanic conform with the work he performed.

(3) That any apprentices employed in the above period are duly registered in a bona fide apprenticeship program registered with a State apprenticeship agency recognized by the Bureau of Apprenticeship and Training, United States Department of Labor, or if no such recognized agency exists in a State, are registered with the Bureau of Apprenticeship and Training, United States Department of Labor.

(4) That:

(a) WHERE FRINGE BENEFITS ARE PAID TO APPROVED PLANS, FUNDS, OR PROGRAMS

- in addition to the basic hourly wage rates paid to each laborer or mechanic listed in the above referenced payroll, payments of fringe benefits as listed in the contract have been or will be made to appropriate programs for the benefit of such employees, except as noted in section 4(c) below.

(b) WHERE FRINGE BENEFITS ARE PAID IN CASH

- Each laborer or mechanic listed in the above referenced payroll has been paid, as indicated on the payroll, an amount not less than the sum of the applicable basic hourly wage rate plus the amount of the required fringe benefits as listed in the contract, except as noted in section 4(c) below.

(c) EXCEPTIONS

EXCEPTION (CRAFT)	EXPLANATION

REMARKS:

NAME AND TITLE Hyon Sang Kim / Operations Manager	SIGNATURE 
THE WILLFUL FALSIFICATION OF ANY OF THE ABOVE STATEMENTS MAY SUBJECT THE CONTRACTOR OR SUBCONTRACTOR TO CIVIL OR CRIMINAL PROSECUTION. SEE SECTION 1001 OF TITLE 18 AND SECTION 231 OF TITLE 31 OF THE UNITED STATES CODE.	



**KORANDO CORPORATION**  
**GENERAL CONTRACTOR**  
PO BOX 20538 GMF, GUAM 96921  
Tel Nos. (671) 649-7880/81 Fax (671) 649-7882

COPY

**BILE / PIGUA BRIDGE REPLACEMENT  
(CONSTRUCTION PHASE)  
PROJECT NO.: GU-NH-NBIS (007)**

**CERTIFIED PAYROLL REPORTS  
FOR WEEK ENDING 04-12-2015**



Stanley Consultants Inc.

  
\_\_\_\_\_  
Signature

4-28-15  
\_\_\_\_\_  
Date

PAYROLL

(For Contractor's Optional Use; See Instructions at [www.dol.gov/whd/forms/wh347instr.htm](http://www.dol.gov/whd/forms/wh347instr.htm))



Persons are not required to respond to the collection of information unless it displays a currently valid OMB control number.

OMB No.: 1235-0008  
Expires: 01/31/2015

NAME OF CONTRACTOR  OR SUBCONTRACTOR   
 KORANDO CORPORATION  
 ADDRESS P.O. BOX 20538  
 BARRIGADA, GUAM 96921

PAYROLL NO. 14 FOR WEEK ENDING 04/12/2015  
 PROJECT AND LOCATION Bile/Pigua Bridge Replacement (Construction Phase)  
 Along Route 4, Merizo, Guam PROJECT OR CONTRACT NO. GU-NH-NBIS (007)

(1) NAME AND INDIVIDUAL IDENTIFYING NUMBER (e.g., LAST FOUR DIGITS OF SOCIAL SECURITY NUMBER) OF WORKER	(2) NO. OF WITHHOLDING EXEMPTIONS	(3) WORK CLASSIFICATION	(4) DAY AND DATE							(5) TOTAL HOURS	(6) RATE OF PAY	(7) GROSS AMOUNT EARNED	(8) DEDUCTIONS					(9) NET WAGES PAID FOR WEEK		
			C	M	T	W	TH	F	SA				SU	FICA	WITH- HOLDING TAX	D/L	A fac Medical		OTHER	TOTAL DEDUCTIONS
				6	7	8	9	10	11				12							
Javelosa, Lauro E. P.O. Box 20538 Barrigada, Guam 96921 5139 S	1	Construction Laborer	C	0.00	0.00	0.00	0.00	2.50	0.00	0.00	2.50	\$19.31	\$563.08	\$43.08	\$57.00	\$35.00	\$0.00	\$0.00	\$135.08	\$428.00
			S	8.50	8.50	8.50	8.50	6.00	0.00	0.00	40.00	12.87	\$563.08							
Leg, Kerman P.O. Box 20538 Barrigada, Guam 96921 2346 M	1	Construction Laborer	C	0.00	0.00	0.00	0.00	0.00	0.00	0.00			\$289.00	\$22.11	\$5.00	\$0.00	\$0.00	\$0.00	\$27.11	\$261.89
			S	8.50	8.50	8.50	0.00	8.50	0.00	0.00	34.00	8.50	\$289.00							
Luzama, Petrus P.O. Box 20538 Barrigada, Guam 96921 9803 S	5	Construction Laborer	C	0.00	0.00	0.00	0.00	0.00	0.00	0.00				\$0.00	\$0.00	\$0.00	\$0.00	\$0.00		
			S	0.00	0.00	0.00	0.00	0.00	0.00	0.00		8.50	\$0.00							
Munar, Florante (H2-B) P.O. Box 20538 Barrigada, Guam 96921 6711 S	1	Carpenter	C	0.00	0.00	0.00	0.00	2.50	0.00	0.00	2.50	\$20.34	\$593.25	\$0.00	\$62.00	\$35.00	\$0.00	\$0.00	\$97.00	\$496.25
			S	8.50	8.50	8.50	8.50	6.00	0.00	0.00	40.00	13.56	\$593.25							
			C																	
			S																	
			C																	
			S																	
			C																	
			S																	

While completion of Form WH-347 is optional, it is mandatory for covered contractors and subcontractors performing work on Federally financed or assisted construction contracts to respond to the information collection contained in 29 C.F.R. §§ 3.3, 5.5(a). The Copeland Act (40 U.S.C. § 3145) contractors and subcontractors performing work on Federally financed or assisted construction contracts to "furnish weekly a statement with respect to the wages paid each employee during the preceding week." U.S. Department of Labor (DOL) regulations at 29 C.F.R. § 5.5(a)(3)(ii) require contractors to submit weekly a copy of all payrolls to the Federal agency contracting for or financing the construction project, accompanied by a signed "Statement of Compliance" indicating that the payrolls are correct and complete and that each laborer or mechanic has been paid not less than the proper Davis-Bacon prevailing wage rate for the work performed. DOL and federal contracting agencies receiving this information review the information to determine that employees have received legally required wages and fringe benefits.

Public Burden Statement

We estimate that it will take an average of 55 minutes to complete this collection, including time for reviewing instructions, searching existing data sources, gathering and maintaining the data needed, and completing and reviewing the collection of information. If you have any comments regarding these estimates or any other aspect of this collection, including suggestions for reducing this burden, send them to the Administrator, Wage and Hour Division, U.S. Department of Labor, Room S3502, 200 Constitution Avenue, N.W., Washington, D.C. 20210



Date 04/15/2015

I, HYON SANG KIM OPERATIONS MANAGER  
(Name of Signatory Party) (Title)

do hereby state:

(1) That I pay or supervise the payment of the persons employed by

KORANDO CORPORATION on the  
(Contractor or Subcontractor)  
380H Harmon Industrial Park, Tamuning, GU, that during the payroll period commencing on the  
(Building or Work)  
6 day of April, 2015, and ending the 12 day of April, 2015

all persons employed on said project have been paid the full weekly wages earned, that no rebates have been or will be made either directly or indirectly to or on behalf of said

KORANDO CORPORATION from the full  
(Contractor or Subcontractor)

weekly wages earned by any person and that no deductions have been made either directly or indirectly from the full wages earned by any person, other than permissible deductions as defined in Regulations, Part 3 (29 C.F.R. Subtitle A), issued by the Secretary of Labor under the Copeland Act, as amended (48 Stat. 948, 63 Stat. 108, 72 Stat. 957; 76 Stat. 357; 40 U.S.C. § 3145), and described below:

\_\_\_\_\_  
\_\_\_\_\_  
\_\_\_\_\_

(2) That any payrolls otherwise under this contract required to be submitted for the above period are correct and complete; that the wage rates for laborers or mechanics contained therein are not less than the applicable wage rates contained in any wage determination incorporated into the contract; that the classifications set forth therein for each laborer or mechanic conform with the work he performed.

(3) That any apprentices employed in the above period are duly registered in a bona fide apprenticeship program registered with a State apprenticeship agency recognized by the Bureau of Apprenticeship and Training, United States Department of Labor, or if no such recognized agency exists in a State, are registered with the Bureau of Apprenticeship and Training, United States Department of Labor.

(4) That:

(a) WHERE FRINGE BENEFITS ARE PAID TO APPROVED PLANS, FUNDS, OR PROGRAMS

- in addition to the basic hourly wage rates paid to each laborer or mechanic listed in the above referenced payroll, payments of fringe benefits as listed in the contract have been or will be made to appropriate programs for the benefit of such employees, except as noted in section 4(c) below.

(b) WHERE FRINGE BENEFITS ARE PAID IN CASH

- Each laborer or mechanic listed in the above referenced payroll has been paid, as indicated on the payroll, an amount not less than the sum of the applicable basic hourly wage rate plus the amount of the required fringe benefits as listed in the contract, except as noted in section 4(c) below.

(c) EXCEPTIONS

EXCEPTION (CRAFT)	EXPLANATION

REMARKS:

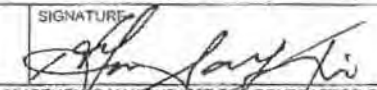
NAME AND TITLE: Hyon Sang Kim / Operations Manager SIGNATURE: 

THE WILLFUL FALSIFICATION OF ANY OF THE ABOVE STATEMENTS MAY SUBJECT THE CONTRACTOR OR SUBCONTRACTOR TO CIVIL OR CRIMINAL PROSECUTION. SEE SECTION 1001 OF TITLE 18 AND SECTION 231 OF TITLE 31 OF THE UNITED STATES CODE.



**KORANDO CORPORATION**  
**GENERAL CONTRACTOR**  
PO BOX 20538 GMF, GUAM 96921  
Tel Nos. (671) 649-7880/81 Fax (671) 649-7882

**COPY**

**BILE / PIGUA BRIDGE REPLACEMENT  
(CONSTRUCTION PHASE)  
PROJECT NO.: GU-NH-NBIS (007)**

**CERTIFIED PAYROLL REPORTS  
FOR WEEK ENDING 04-19-2015**



Stanley Consultants Inc.

*[Handwritten Signature]*  
\_\_\_\_\_  
Signature

4-28-15  
\_\_\_\_\_  
Date

PAYROLL

(For Contractor's Optional Use; See Instructions at [www.dol.gov/whd/forms/wh347instr.htm](http://www.dol.gov/whd/forms/wh347instr.htm))



Persons are not required to respond to the collection of information unless it displays a currently valid OMB control number.

NAME OF CONTRACTOR  OR SUBCONTRACTOR   
 KORANDO CORPORATION  
 ADDRESS P.O. BOX 20538  
 BARRIGADA, GUAM 96921  
 OMB No.: 1235-0008  
 Expires: 01/31/2015

PAYROLL NO. 15 FOR WEEK ENDING 04/19/2015  
 PROJECT AND LOCATION Bile/Pigua Bridge Replacement (Construction Phase)  
 Along Route 4, Merizo, Guam  
 PROJECT OR CONTRACT NO. GU-NH-NBIS (007)

(1) NAME AND INDIVIDUAL IDENTIFYING NUMBER (e.g., LAST FOUR DIGITS OF SOCIAL SECURITY NUMBER) OF WORKER	(2) NO. OF WITH-HOLDING EXEMPTIONS	(3) WORK CLASSIFICATION	(4) DAY AND DATE							(5) TOTAL HOURS	(6) RATE OF PAY	(7) GROSS AMOUNT EARNED	(8) DEDUCTIONS					(9) NET WAGES PAID FOR WEEK				
			OT OR BT	M	T	W	TH	F	SA				SU	FICA	WITH- HOLDING TAX	BIT	Affac Medical		OTHER	TOTAL DEDUCTIONS		
				13	14	15	16	17	18				19								HOURS WORKED EACH DAY	
Javelosa, Lauro E. P.O. Box 20538 Barrigada, Guam 96921	5139 S	1	Construction Laborer	O	0.00	0.00	0.00	0.00	2.50	0.00	0.00	2.50	\$19.31	\$563.08	\$43.07	\$57.00	\$35.00	\$0.00	\$0.00	\$135.07	\$428.01	
				S	8.50	2.50	8.50	2.50	6.00	0.00	0.00	40.00	12.87	\$563.08								
Leg, Kerman P.O. Box 20538 Barrigada, Guam 96921	2346 M	1	Construction Laborer	O	0.00	0.00	0.00	0.00	0.00	0.00	0.00			\$216.75	\$16.58	\$0.00	\$0.00	\$0.00	\$0.00	\$16.58	\$200.17	
				S	0.00	8.50	8.50	0.00	8.50	0.00	0.00	25.50	8.50	\$216.75								
Luzama, Petrus P.O. Box 20538 Barrigada, Guam 96921	9803 S	5	Construction Laborer	O	0.00	0.00	0.00	0.00	0.00	0.00	0.00				\$0.00	\$0.00	\$0.00	\$0.00	\$0.00			
				S	0.00	0.00	0.00	0.00	0.00	0.00	0.00		8.50	\$0.00								
Munar, Florante (H2-B) P.O. Box 20538 Barrigada, Guam 96921	6711 S	1	Carpenter	O	0.00	0.00	0.00	0.00	2.50	0.00	0.00	2.50	\$20.34	\$593.25	\$0.00	\$62.00	\$35.00	\$0.00	\$0.00	\$97.00	\$496.25	
				S	8.50	8.50	8.50	2.50	6.00	0.00	0.00	40.00	13.56	\$593.25								
Bansil, Ray P.O. Box 20538 Barrigada, Guam 96921	3135 M	3	Carpenter	O	0.00	0.00	0.00	0.00	2.50	0.00	0.00	2.50	\$21.00	\$612.50	\$42.73	\$16.00	\$0.00	\$53.97	\$0.00	\$112.70	\$499.80	
				S	8.50	8.50	8.50	8.50	0.00	0.00	0.00	40.00	14.00	\$612.50								
				O																		
				S																		

While completion of Form WH-347 is optional, it is mandatory for covered contractors and subcontractors performing work on Federally financed or assisted construction contracts to respond to the information collection contained in 29 C.F.R. §§ 3.3, 5.5(a). The Copeland Act (40 U.S.C. § 3145) contractors and subcontractors performing work on Federally financed or assisted construction contracts to "furnish weekly a statement with respect to the wages paid each employee during the preceding week." U.S. Department of Labor (DOL) regulations at 29 C.F.R. § 5.5(a)(3)(ii) require contractors to submit weekly a copy of all payrolls to the Federal agency contracting for or financing the construction project, accompanied by a signed "Statement of Compliance" indicating that the payrolls are correct and complete and that each laborer or mechanic has been paid not less than the proper Davis-Bacon prevailing wage rate for the work performed. DOL and federal contracting agencies receiving this information review the information to determine that employees have received legally required wages and fringe benefits.

Public Burden Statement

We estimate that it will take an average of 55 minutes to complete this collection, including time for reviewing instructions, searching existing data sources, gathering and maintaining the data needed, and completing and reviewing the collection of information, if you have any comments regarding these estimates or any other aspect of this collection, including suggestions for reducing this burden, send them to the Administrator, Wage and Hour Division, U.S. Department of Labor, Room S3502, 200 Constitution Avenue, N.W., Washington, D.C. 20210







**KORANDO CORPORATION**  
**GENERAL CONTRACTOR**  
PO BOX 20538 GMF, GUAM 96921  
Tel Nos. (671) 649-7880/81 Fax (671) 649-7882

COPY

**BILE / PIGUA BRIDGE REPLACEMENT  
(CONSTRUCTION PHASE)  
PROJECT NO.: GU-NH-NBIS (007)**

**CERTIFIED PAYROLL REPORTS  
FOR WEEK ENDING 04-26-2015**



Stanley Consultants Inc.

*[Handwritten Signature]*  
Signature

*[Handwritten Date]*  
Date 31



PAYROLL

(For Contractor's Optional Use; See Instructions at [www.dol.gov/whd/forms/wh347instr.htm](http://www.dol.gov/whd/forms/wh347instr.htm))

Persons are not required to respond to the collection of information unless it displays a currently valid OMB control number.

NAME OF CONTRACTOR <input checked="" type="checkbox"/> OR SUBCONTRACTOR <input type="checkbox"/>		ADDRESS		OMB No.: 1235-0008
KORANDO CORPORATION		P.O. BOX 20538 BARRIGADA, GUAM 96921		Expires: 01/31/2015
PAYROLL NO. 16	FOR WEEK ENDING 04/26/2015	PROJECT AND LOCATION Bile/Pigua Bridge Replacement (Construction Phase) Along Route 4, Merizo, Guam		PROJECT OR CONTRACT NO. GU-NH-NBIS (007)

(1) NAME AND INDIVIDUAL IDENTIFYING NUMBER (e.g., LAST FOUR DIGITS OF SOCIAL SECURITY NUMBER) OF WORKER	(2) NO. OF WITHHOLDING EXEMPTIONS	(3) WORK CLASSIFICATION	(4) DAY AND DATE							(5) TOTAL HOURS	(6) RATE OF PAY	(7) GROSS AMOUNT EARNED	(8) DEDUCTIONS					(9) NET WAGES PAID FOR WEEK		
			OT OR ST.	M	T	W	TH	F	SA				SU	FICA	WITH-HOLDING TAX	D/L	Alloc Medical		OTHER	TOTAL DEDUCTIONS
				20	21	22	23	24	25				26							
Javelosa, Lauro E. P.O. Box 20538 Barrigada, Guam 96921	5139 S	1 Construction Laborer	O	0.00	0.00	0.00	0.00	2.50	0.00	0.00	2.50	\$19.31	\$563.08	\$43.09	\$57.00	\$35.00	\$0.00	\$0.00	\$135.09	\$427.99
			S	3.50	8.50	8.50	8.50	8.00	0.00	0.00	40.00	12.87	\$563.08							
Leg, Kerman P.O. Box 20538 Barrigada, Guam 96921	2346 M	1 Construction Laborer	O	0.00	0.00	0.00	0.00	0.00	0.00	0.00			\$289.00	\$22.10	\$5.00	\$0.00	\$0.00	\$0.00	\$27.10	\$261.90
			S	8.50	8.50	8.50	8.50	0.00	0.00	0.00	34.00	8.50	\$289.00							
Luzama, Petrus P.O. Box 20538 Barrigada, Guam 96921	9803 S	5 Construction Laborer	O	0.00	0.00	0.00	0.00	0.00	0.00	0.00				\$0.00	\$0.00	\$0.00	\$0.00	\$0.00	\$0.00	\$0.00
			S	0.00	0.00	0.00	0.00	0.00	0.00	0.00		8.50	\$0.00							
Munar, Florante (H2-B) P.O. Box 20538 Barrigada, Guam 96921	6711 S	1 Carpenter	O	0.00	3.00	0.00	0.00	0.00	0.00	0.00		\$20.34	\$461.04	\$0.00	\$67.00	\$35.00	\$0.00	\$0.00	\$102.00	\$521.76
			S	8.50	8.50	8.50	8.50	0.00	0.00	0.00	34.00	13.56	\$623.76							
Bansil, Ray P.O. Box 20538 Barrigada, Guam 96921	3135 M	3 Carpenter	O	0.00	0.00	0.00	0.00	2.50	0.00	0.00	2.50	\$21.00	\$612.50	\$42.73	\$16.00	\$0.00	\$53.97	\$200.00	\$312.70	\$299.80
			S	8.50	8.50	8.50	8.50	6.00	0.00	0.00	40.00	14.00	\$612.50							
Pascua, Ernesto B. (H2-B) P.O. Box 20538 Barrigada, Guam 96921	5212 S	1 Heavy Equipment Operator	O	0.00	0.00	0.00	0.00	2.50	0.00	0.00	2.50	\$20.66	\$602.45	\$0.00	\$63.00	\$35.00	\$0.00	\$0.00	\$98.00	\$504.45
			S	8.50	8.50	8.50	8.50	6.00	0.00	0.00	40.00	13.77	\$602.45							
			O																	
			S																	
			O																	
			S																	

While completion of Form WH-347 is optional, it is mandatory for covered contractors and subcontractors performing work on Federally financed or assisted construction contracts to respond to the information collection contained in 29 C.F.R. §§ 3.3, 5.5(a). The Copeland Act (40 U.S.C. § 3145) contractors and subcontractors performing work on Federally financed or assisted construction contracts to "furnish weekly a statement with respect to the wages paid each employee during the preceding week." U.S. Department of Labor (DOL) regulations at 29 C.F.R. § 5.5(a)(3)(ii) require contractors to submit weekly a copy of all payrolls to the Federal agency contracting for or financing the construction project, accompanied by a signed "Statement of Compliance" indicating that the payrolls are correct and complete and that each laborer or mechanic has been paid not less than the proper Davis-Bacon prevailing wage rate for the work performed. DOL and federal contracting agencies receiving this information review the information to determine that employees have received legally required wages and fringe benefits.

Public Burden Statement

We estimate that it will take an average of 55 minutes to complete this collection, including time for reviewing instructions, searching existing data sources, gathering and maintaining the data needed, and completing and reviewing the collection of information. If you have any comments regarding these estimates or any other aspect of this collection, including suggestions for reducing this burden, send them to the Administrator, Wage and Hour Division, U.S. Department of Labor, Room S3502, 200 Constitution Avenue, N.W., Washington, D.C. 20210



Date 04/28/2015

I, HYON SANG KIM OPERATIONS MANAGER  
(Name of Signatory Party) (Title)

do hereby state:

(1) That I pay or supervise the payment of the persons employed by

KORANDO CORPORATION on the  
(Contractor or Subcontractor)

380H Harmon Industrial Park, Tamuning, GU; that during the payroll period commencing on the  
(Building or Work)

20 day of April, 2015, and ending the 26 day of April, 2015

all persons employed on said project have been paid the full weekly wages earned, that no rebates have been or will be made either directly or indirectly to or on behalf of said

KORANDO CORPORATION from the full  
(Contractor or Subcontractor)

weekly wages earned by any person and that no deductions have been made either directly or indirectly from the full wages earned by any person, other than permissible deductions as defined in Regulations, Part 3 (29 C.F.R. Subtitle A), issued by the Secretary of Labor under the Copeland Act, as amended (48 Stat. 948, 63 Stat. 108, 72 Stat. 967; 76 Stat. 357; 40 U.S.C. § 3145), and described below:

For PPE: 04/20 - 26/2015, Ray Bansil: Other deductions of \$200.00 is Cash Advance repayment

(2) That any payrolls otherwise under this contract required to be submitted for the above period are correct and complete; that the wage rates for laborers or mechanics contained therein are not less than the applicable wage rates contained in any wage determination incorporated into the contract; that the classifications set forth therein for each laborer or mechanic conform with the work he performed.

(3) That any apprentices employed in the above period are duly registered in a bona fide apprenticeship program registered with a State apprenticeship agency recognized by the Bureau of Apprenticeship and Training, United States Department of Labor, or if no such recognized agency exists in a State, are registered with the Bureau of Apprenticeship and Training, United States Department of Labor.

(4) That:

(a) WHERE FRINGE BENEFITS ARE PAID TO APPROVED PLANS, FUNDS, OR PROGRAMS

- In addition to the basic hourly wage rates paid to each laborer or mechanic listed in the above referenced payroll, payments of fringe benefits as listed in the contract have been or will be made to appropriate programs for the benefit of such employees, except as noted in section 4(c) below.

(b) WHERE FRINGE BENEFITS ARE PAID IN CASH

- Each laborer or mechanic listed in the above referenced payroll has been paid, as indicated on the payroll, an amount not less than the sum of the applicable basic hourly wage rate plus the amount of the required fringe benefits as listed in the contract, except as noted in section 4(c) below.

(c) EXCEPTIONS

EXCEPTION (CRAFT)	EXPLANATION

REMARKS:

NAME AND TITLE  
Hyon Sang Kim / Operations Manager

SIGNATURE  

THE WILLFUL FALSIFICATION OF ANY OF THE ABOVE STATEMENTS MAY SUBJECT THE CONTRACTOR OR SUBCONTRACTOR TO CIVIL OR CRIMINAL PROSECUTION. SEE SECTION 1001 OF TITLE 18 AND SECTION 231 OF TITLE 31 OF THE UNITED STATES CODE.



**KORANDO CORPORATION**

**GENERAL CONTRACTOR**

PO BOX 20538 GMF, GUAM 96921

Tel Nos. (671) 649-7880/81 Fax (671) 649-7882

**COPY**

**BILE / PIGUA BRIDGE REPLACEMENT  
(CONSTRUCTION PHASE)  
PROJECT NO.: GU-NH-NBIS (007)**

**CERTIFIED PAYROLL REPORTS  
FOR WEEK ENDING 05-03-2015**



Stanley Consultants Inc.

*[Handwritten Signature]*  
Signature

5-14 @  
Date 1/02



PAYROLL

(For Contractor's Optional Use; See Instructions at [www.dol.gov/whd/forms/wh347instr.htm](http://www.dol.gov/whd/forms/wh347instr.htm))



Persons are not required to respond to the collection of information unless it displays a currently valid OMB control number.

Rev. Dec. 2008

NAME OF CONTRACTOR <input checked="" type="checkbox"/> OR SUBCONTRACTOR <input type="checkbox"/>	ADDRESS	OMB No.: 1235-0008 Expires: 01/31/2015
KORANDO CORPORATION	P.O. BOX 20538 BARRIGADA, GUAM 96921	

PAYROLL NO. 17	FOR WEEK ENDING 05/03/2015	PROJECT AND LOCATION Bile/Pigua Bridge Replacement (Construction Phase) Along Route 4, Merizo, Guam	PROJECT OR CONTRACT NO. GU-NH-NBIS (007)
-------------------	-------------------------------	---	---

(1) NAME AND INDIVIDUAL IDENTIFYING NUMBER (e.g., LAST FOUR DIGITS OF SOCIAL SECURITY NUMBER) OF WORKER	(2) NO. OF WITHHOLDING EXEMPTIONS	(3) WORK CLASSIFICATION	(4) DAY AND DATE							(5) TOTAL HOURS	(6) RATE OF PAY	(7) GROSS AMOUNT EARNED	(8) DEDUCTIONS					(9) NET WAGES PAID FOR WEEK			
			OT OR SL	M	T	W	TH	F	SA				SU	FICA	WITH- HOLDING TAX	U/L	Affric Medical		OTHER	TOTAL DEDUCTIONS	
				27	28	29	30	1	2				3								HOURS WORKED EACH DAY
Javelosa, Lauro E. P.O. Box 20538 Barrigada, Guam 96921	5139 S	1	Construction Laborer	O	0.00	0.00	0.00	0.00	0.00	0.00	0.00		\$19.31	\$437.58	\$42.33	\$56.00	\$35.00	\$0.00	\$0.00	\$133.33	\$420.09
				S	8.50	8.50	8.50	8.50	0.00	0.00	0.00	34.00	12.87	\$553.42							
Leg, Kerman P.O. Box 20538 Barrigada, Guam 96921	2346 M	1	Construction Laborer	O	0.00	0.00	0.00	0.00	0.00	0.00	0.00		\$12.75	\$289.00	\$22.11	\$5.00	\$0.00	\$0.00	\$0.00	\$27.11	\$261.89
				S	0.00	8.50	8.50	8.50	8.50	0.00	0.00	34.00	8.50	\$289.00							
Wada, Matthew P.O. Box 20538 Barrigada, Guam 96921	3262 S	1	Apprenticeship (Cement Mason)	O	0.00	0.00	0.00	0.00	0.00	0.00	0.00		\$14.48	\$246.08	\$18.83	\$12.00	\$0.00	\$0.00	\$0.00	\$30.83	\$215.25
				S	0.00	0.00	8.50	8.50	8.50	0.00	0.00	25.50	9.65	\$246.08							
Munar, Florante (H2-B) P.O. Box 20538 Barrigada, Guam 96921	6711 S	1	Carpenter	O	0.00	0.00	0.00	0.00	2.50	0.00	0.00	2.50	\$20.34	\$593.25	\$0.00	\$62.00	\$35.00	\$0.00	\$0.00	\$97.00	\$496.25
				S	8.50	8.50	8.50	8.50	6.00	0.00	0.00	40.00	13.56	\$593.25							
Bansil, Ray P.O. Box 20538 Barrigada, Guam 96921	3135 M	3	Carpenter	O	0.00	0.00	0.00	0.00	2.50	0.00	0.00	2.50	\$21.00	\$612.50	\$42.72	\$16.00	\$0.00	\$53.97	\$200.00	\$312.69	\$299.81
				S	8.50	8.50	8.50	8.50	0.00	0.00	0.00	40.00	14.00	\$612.50							
Pascua, Ernesto B. (H2-B) P.O. Box 20538 Barrigada, Guam 96921	5212 S	1	Heavy Equipment Operator	O	0.00	0.00	0.00	0.00	2.50	0.00	0.00	2.50	\$20.66	\$602.45	\$0.00	\$63.00	\$35.00	\$0.00	\$0.00	\$98.00	\$504.45
				S	8.50	8.50	8.50	8.50	0.00	0.00	0.00	40.00	13.77	\$602.45							
Bansil, Raul (H2-B) P.O. Box 20538 Barrigada, Guam 96921	8167 S	1	Cement Mason	O	0.00	0.00	0.00	0.00	0.00	0.00	0.00		\$19.31	\$109.40	\$0.00	\$52.00	\$35.00	\$0.00	\$0.00	\$87.00	\$437.46
				S	0.00	0.00	0.00	0.00	8.50	0.00	0.00	8.50	12.87	\$524.46							

While completion of Form WH-347 is optional, it is mandatory for covered contractors and subcontractors performing work on Federally financed or assisted construction contracts to respond to the information collection contained in 29 C.F.R. §§ 3.3, 5.5(a). The Copeland Act (40 U.S.C. § 3145) contractors and subcontractors performing work on Federally financed or assisted construction contracts to "furnish weekly a statement with respect to the wages paid each employee during the preceding week." U.S. Department of Labor (DOL) regulations at 29 C.F.R. § 5.5(a)(3)(ii) require contractors to submit weekly a copy of all payrolls to the Federal agency contracting for or financing the construction project, accompanied by a signed "Statement of Compliance" indicating that the payrolls are correct and complete and that each laborer or mechanic has been paid not less than the proper Davis-Bacon prevailing wage rate for the work performed. DOL and federal contracting agencies receiving this information review the information to determine that employees have received legally required wages and fringe benefits.

Public Burden Statement

We estimate that it will take an average of 55 minutes to complete this collection, including time for reviewing instructions, searching existing data sources, gathering and maintaining the data needed, and completing and reviewing the collection of information. If you have any comments regarding these estimates or any other aspect of this collection, including suggestions for reducing this burden, send them to the Administrator, Wage and Hour Division, U.S. Department of Labor, Room S3502, 200 Constitution Avenue, N.W., Washington, D.C. 20210



Date 05/06/2015

I, HYON SANG KIM OPERATIONS MANAGER  
(Name of Signatory Party) (Title)

do hereby state:

(1) That I pay or supervise the payment of the persons employed by

KORANDO CORPORATION on the  
(Contractor or Subcontractor)

380H Harmon Industrial Park, Tamuning, GU; that during the payroll period commencing on the  
(Building or Work)

27 day of April, 2015, and ending the 03 day of May, 2015,

all persons employed on said project have been paid the full weekly wages earned, that no rebates have been or will be made either directly or indirectly to or on behalf of said

KORANDO CORPORATION from the full  
(Contractor or Subcontractor)

weekly wages earned by any person and that no deductions have been made either directly or indirectly from the full wages earned by any person, other than permissible deductions as defined in Regulations, Part 3 (29 C.F.R. Subtitle A), issued by the Secretary of Labor under the Copeland Act, as amended (48 Stat. 948, 63 Stat. 108, 72 Stat. 967; 76 Stat. 357; 40 U.S.C. § 3145), and described below:

For PPE: 04/27 - 05/03/2015, Ray Bansil: Other deductions of \$200.00 is Cash Advance

repayment.

(2) That any payrolls otherwise under this contract required to be submitted for the above period are correct and complete; that the wage rates for laborers or mechanics contained therein are not less than the applicable wage rates contained in any wage determination incorporated into the contract; that the classifications set forth therein for each laborer or mechanic conform with the work he performed.

(3) That any apprentices employed in the above period are duly registered in a bona fide apprenticeship program registered with a State apprenticeship agency recognized by the Bureau of Apprenticeship and Training, United States Department of Labor, or if no such recognized agency exists in a State, are registered with the Bureau of Apprenticeship and Training, United States Department of Labor.

(4) That:

(a) WHERE FRINGE BENEFITS ARE PAID TO APPROVED PLANS, FUNDS, OR PROGRAMS

- in addition to the basic hourly wage rates paid to each laborer or mechanic listed in the above referenced payroll, payments of fringe benefits as listed in the contract have been or will be made to appropriate programs for the benefit of such employees, except as noted in section 4(c) below.

(b) WHERE FRINGE BENEFITS ARE PAID IN CASH

- Each laborer or mechanic listed in the above referenced payroll has been paid, as indicated on the payroll, an amount not less than the sum of the applicable basic hourly wage rate plus the amount of the required fringe benefits as listed in the contract, except as noted in section 4(c) below.

(c) EXCEPTIONS

EXCEPTION (CRAFT)	EXPLANATION

REMARKS:

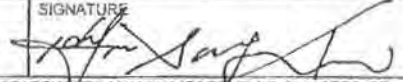
NAME AND TITLE Hyon Sang Kim / Operations Manager	SIGNATURE 
THE WILLFUL FALSIFICATION OF ANY OF THE ABOVE STATEMENTS MAY SUBJECT THE CONTRACTOR OR SUBCONTRACTOR TO CIVIL OR CRIMINAL PROSECUTION. SEE SECTION 1001 OF TITLE 18 AND SECTION 231 OF TITLE 31 OF THE UNITED STATES CODE.	



**KORANDO CORPORATION**

**GENERAL CONTRACTOR**

PO BOX 20538 GMF, GUAM 96921

Tel Nos. (671) 649-7880/81 Fax (671) 649-7882

**COPY**

**BILE / PIGUA BRIDGE REPLACEMENT  
(CONSTRUCTION PHASE)  
PROJECT NO.: GU-NH-NBIS (007)**

**CERTIFIED PAYROLL REPORTS  
FOR WEEK ENDING 05-10-2015**

	
 Signature	inc. 5-14@ Date 102



U.S. Department of Labor  
Wage and Hour Division

PAYROLL

(For Contractor's Optional Use; See Instructions at [www.dol.gov/whd/forms/wh347instr.htm](http://www.dol.gov/whd/forms/wh347instr.htm))



Persons are not required to respond to the collection of information unless it displays a currently valid OMB control number.

NAME OF CONTRACTOR <input checked="" type="checkbox"/> OR SUBCONTRACTOR <input type="checkbox"/>		ADDRESS		OMB No.: 1235-0008
KORANDO CORPORATION		P.O. BOX 20538 BARRIGADA, GUAM 96921		Expires: 01/31/2015
PAYROLL NO. 18	(Page 1 of 2)	FOR WEEK ENDING 05/10/2015	PROJECT AND LOCATION Bile/Pigua Bridge Replacement (Construction Phase) Along Route 4, Merizo, Guam	PROJECT OR CONTRACT NO. GU-NH-NBIS (007)

(1) NAME AND INDIVIDUAL IDENTIFYING NUMBER (e.g. LAST FOUR DIGITS OF SOCIAL SECURITY NUMBER) OF WORKER	(2) NO. OF WITHHOLDING EXEMPTIONS	(3) WORK CLASSIFICATION	(4) DAY AND DATE							(5) TOTAL HOURS	(6) RATE OF PAY	(7) GROSS AMOUNT EARNED	(8) DEDUCTIONS					(9) NET WAGES PAID FOR WEEK			
			OT, OR BT.	M	T	W	TH	F	SA				SU	FICA	WITH- HOLDING TAX	B/L	Affac Medical		OTHER	TOTAL DEDUCTIONS	
				4	5	6	7	8	9				10								HOURS WORKED EACH DAY
Javelosa, Lauro E. P.O. Box 20538 Barrigada, Guam 96921	5139 S	Construction Laborer	O	0.00	0.00	0.00	0.00	0.00	0.00	0.00	0.00	2.00	\$19.31	\$25.74	\$40.11	\$52.00	\$35.00	\$0.00	\$0.00	\$127.11	\$397.31
			S	0.00	0.00	0.00	0.00	0.00	0.00	0.00	0.00	0.00	0.00	0.00							
Leg, Kerman P.O. Box 20538 Barrigada, Guam 96921	2346 M	Construction Laborer	O	0.00	0.00	0.00	0.00	2.50	0.00	0.00	0.00	2.50	\$12.75	\$371.88	\$28.46	\$13.00	\$0.00	\$0.00	\$0.00	\$41.46	\$330.42
			S	8.50	8.50	8.50	8.50	6.00	0.00	0.00	40.00	8.50	0.00	0.00							
Wada, Matthew P.O. Box 20538 Barrigada, Guam 96921	3262 S	Apprenticeship (Cement Mason)	O	0.00	0.00	0.00	0.00	2.50	0.00	0.00	0.00	2.50	\$14.48	\$422.20	\$32.29	\$36.00	\$0.00	\$0.00	\$0.00	\$68.29	\$353.91
			S	8.50	8.50	8.50	8.50	6.00	0.00	0.00	40.00	9.65	0.00	0.00							
Munar, Florante (H2-B) P.O. Box 20538 Barrigada, Guam 96921	6711 S	Carpenter	O	0.00	0.00	0.00	0.00	2.50	0.00	0.00	0.00	2.50	\$20.34	\$593.25	\$0.00	\$62.00	\$35.00	\$0.00	\$0.00	\$97.00	\$496.25
			S	8.50	8.50	8.50	8.50	6.00	0.00	0.00	40.00	13.56	0.00	0.00							
Bansil, Ray P.O. Box 20538 Barrigada, Guam 96921	3135 M	Carpenter	O	0.00	0.00	0.00	0.00	0.00	0.00	0.00	0.00		\$21.00	\$476.00	\$41.93	\$15.00	\$0.00	\$53.97	\$0.00	\$110.90	\$491.10
			S	8.50	8.50	8.50	8.50	0.00	0.00	0.00	34.00	14.00	0.00	0.00							
Pascua, Ernesto B. (H2-B) P.O. Box 20538 Barrigada, Guam 96921	5212 S	Heavy Equipment Operator	O	0.00	0.00	0.00	0.00	2.50	0.00	0.00	0.00	2.50	\$20.66	\$602.45	\$0.00	\$63.00	\$35.00	\$0.00	\$0.00	\$98.00	\$504.45
			S	8.50	8.50	8.50	8.50	6.00	0.00	0.00	40.00	13.77	0.00	0.00							
Bansil, Raul (H2-B) P.O. Box 20538 Barrigada, Guam 96921	8167 S	Cement Mason	O	0.00	0.00	0.00	0.00	2.50	0.00	0.00	0.00	2.50	\$19.31	\$563.08	\$0.00	\$57.00	\$35.00	\$0.00	\$0.00	\$92.00	\$471.08
			S	8.50	8.50	8.50	8.50	6.00	0.00	0.00	40.00	12.87	0.00	0.00							
Ichin, A.S. P.O. Box 20538 Barrigada, Guam 96921	8409 S	Apprenticeship (Cement Mason)	O	0.00	0.00	0.00	0.00	2.50	0.00	0.00	0.00	2.50	\$14.48	\$422.20	\$32.31	\$36.00	\$0.00	\$0.00	\$0.00	\$63.31	\$353.89
			S	8.50	8.50	8.50	8.50	6.00	0.00	0.00	40.00	9.65	0.00	0.00							

While completion of Form WH-347 is optional, it is mandatory for covered contractors and subcontractors performing work on Federally financed or assisted construction contracts to respond to the information collection contained in 29 C.F.R. §§ 3.3, 5.6(a). The Copeland Act (40 U.S.C. § 3145) contractors and subcontractors performing work on Federally financed or assisted construction contracts to "furnish weekly a statement with respect to the wages paid each employee during the preceding week." U.S. Department of Labor (DOL) regulations at 29 C.F.R. § 5.5(a)(3)(i) require contractors to submit weekly a copy of all payrolls to the Federal agency contracting for or financing the construction project, accompanied by a signed "Statement of Compliance" indicating that the payrolls are correct and complete and that each laborer or mechanic has been paid not less than the proper Davis-Bacon prevailing wage rate for the work performed. DOL and federal contracting agencies receiving this information review the information to determine that employees have received legally required wages and fringe benefits.

Public Burden Statement

We estimate that it will take an average of 55 minutes to complete this collection, including time for reviewing instructions, searching existing data sources, gathering and maintaining the data needed, and completing and reviewing the collection of information. If you have any comments regarding these estimates or any other aspect of this collection, including suggestions for reducing this burden, send them to the Administrator, Wage and Hour Division, U.S. Department of Labor, Room S3502, 200 Constitution Avenue, N.W., Washington, D.C. 20210



PAYROLL

(For Contractor's Optional Use; See Instructions at [www.dol.gov/whd/forms/wh347instr.htm](http://www.dol.gov/whd/forms/wh347instr.htm))



Persons are not required to respond to the collection of information unless it displays a currently valid OMB control number.

NAME OF CONTRACTOR  OR SUBCONTRACTOR   
 KORANDO CORPORATION  
 ADDRESS P.O. BOX 20538  
 BARRIGADA, GUAM 96921  
 OMB No.: 1235-0008  
 Expires: 01/31/2015

PAYROLL NO. 18 (Page 2 of 2) FOR WEEK ENDING 05/10/2015  
 PROJECT AND LOCATION Bile/Pigua Bridge Replacement (Construction Phase)  
 Along Route 4, Merizo, Guam  
 PROJECT OR CONTRACT NO. GU-NH-NBIS (007)

(1) NAME AND INDIVIDUAL IDENTIFYING NUMBER (e.g., LAST FOUR DIGITS OF SOCIAL SECURITY NUMBER) OF WORKER	(2) NO. OF WITHHOLDING EXEMPTIONS	(3) WORK CLASSIFICATION	(4) DAY AND DATE							(5) TOTAL HOURS	(6) RATE OF PAY	(7) GROSS AMOUNT EARNED	(8) DEDUCTIONS					(9) NET WAGES PAID FOR WEEK				
			OT, OR ST.	M	T	W	TH	F	SA				SU	FICA	WITH- HOLDING TAX	D/L	A/Rac Medical		OTHER	TOTAL DEDUCTIONS		
				4	5	6	7	8	9				10								HOURS WORKED EACH DAY	
Bansil, Jesus M. P.O. Box 20538 Barrigada, Guam 96921	9256 M 3	Cement Mason	O	0.00	0.00	0.00	0.00	0.00	0.00	0.00		\$19.31	\$109.40									
			S	0.00	0.00	0.00	0.00	1.50	0.00	0.00	8.50	12.87	\$621.02	\$47.50	\$22.00	\$0.00	\$0.00	\$0.00	\$69.50	\$551.52		
			O																			
			S																			
			O																			
			S																			
			O																			
			S																			
			O																			
			S																			
			O																			
			S																			

While completion of Form WH-347 is optional, it is mandatory for covered contractors and subcontractors performing work on Federally financed or assisted construction contracts to respond to the information collection contained in 29 C.F.R. §§ 3.3, 5.5(a). The Copeland Act (40 U.S.C. § 3145) contractors and subcontractors performing work on Federally financed or assisted construction contracts to "furnish weekly a statement with respect to the wages paid each employee during the preceding week." U.S. Department of Labor (DOL) regulations at 29 C.F.R. § 5.5(a)(3)(ii) require contractors to submit weekly a copy of all payrolls to the Federal agency contracting for or financing the construction project, accompanied by a signed "Statement of Compliance" indicating that the payrolls are correct and complete and that each laborer or mechanic has been paid not less than the proper Davis-Bacon prevailing wage rate for the work performed. DOL and federal contracting agencies receiving this information review the information to determine that employees have received legally required wages and fringe benefits.

Public Burden Statement

We estimate that it will take an average of 55 minutes to complete this collection, including time for reviewing instructions, searching existing data sources, gathering and maintaining the data needed, and completing and reviewing the collection of information. If you have any comments regarding these estimates or any other aspect of this collection, including suggestions for reducing this burden, send them to the Administrator, Wage and Hour Division, U.S. Department of Labor, Room S3502, 205 Constitution Avenue, N.W., Washington, D.C. 20210

Date 05/12/2015

I, HYON SANG KIM OPERATIONS MANAGER  
(Name of Signatory Party) (Title)

do hereby state:

(1) That I pay or supervise the payment of the persons employed by

KORANDO CORPORATION on the  
(Contractor or Subcontractor)

380H Harmon Industrial Park, Tamuning, GU; that during the payroll period commencing on the  
(Building or Work)

04 day of May, 2015, and ending the 10 day of May, 2015

all persons employed on said project have been paid the full weekly wages earned, that no rebates have been or will be made either directly or indirectly to or on behalf of said

KORANDO CORPORATION from the full  
(Contractor or Subcontractor)

weekly wages earned by any person and that no deductions have been made either directly or indirectly from the full wages earned by any person, other than permissible deductions as defined in Regulations, Part 3 (29 C.F.R. Subtitle A), issued by the Secretary of Labor under the Copeland Act, as amended (48 Stat. 948, 63 Stat. 108, 72 Stat. 967; 76 Stat. 357; 40 U.S.C. § 3145), and described below:

\_\_\_\_\_  
\_\_\_\_\_  
\_\_\_\_\_

(2) That any payrolls otherwise under this contract required to be submitted for the above period are correct and complete; that the wage rates for laborers or mechanics contained therein are not less than the applicable wage rates contained in any wage determination incorporated into the contract; that the classifications set forth therein for each laborer or mechanic conform with the work he performed.

(3) That any apprentices employed in the above period are duly registered in a bona fide apprenticeship program registered with a State apprenticeship agency recognized by the Bureau of Apprenticeship and Training, United States Department of Labor, or if no such recognized agency exists in a State, are registered with the Bureau of Apprenticeship and Training, United States Department of Labor.

(4) That:

(a) WHERE FRINGE BENEFITS ARE PAID TO APPROVED PLANS, FUNDS, OR PROGRAMS

- in addition to the basic hourly wage rates paid to each laborer or mechanic listed in the above referenced payroll, payments of fringe benefits as listed in the contract have been or will be made to appropriate programs for the benefit of such employees, except as noted in section 4(c) below.

(b) WHERE FRINGE BENEFITS ARE PAID IN CASH

- Each laborer or mechanic listed in the above referenced payroll has been paid, as indicated on the payroll, an amount not less than the sum of the applicable basic hourly wage rate plus the amount of the required fringe benefits as listed in the contract, except as noted in section 4(c) below.

(c) EXCEPTIONS

EXCEPTION (CRAFT)	EXPLANATION

REMARKS

NAME AND TITLE  
Hyon Sang Kim / Operations Manager

SIGNATURE  
*Hyon Sang Kim* 5-12-15

THE WILLFUL FALSIFICATION OF ANY OF THE ABOVE STATEMENTS MAY SUBJECT THE CONTRACTOR OR SUBCONTRACTOR TO CIVIL OR CRIMINAL PROSECUTION. SEE SECTION 1001 OF TITLE 18 AND SECTION 231 OF TITLE 31 OF THE UNITED STATES CODE.



**KORANDO CORPORATION**

**GENERAL CONTRACTOR**

PO BOX 20538 GMF, GUAM 96921

Tel Nos. (671) 649-7880/81 Fax (671) 649-7882

**COPY**

**BILE / PIGUA BRIDGE REPLACEMENT  
(CONSTRUCTION PHASE)  
PROJECT NO.: GU-NH-NBIS (007)**

**CERTIFIED PAYROLL REPORTS  
FOR WEEK ENDING 05-17-2015**

RECEIVED 5/26/15 3:00 PM  
@ SITE MEETING

C. RICHARDS



U.S. Department of Labor  
Wage and Hour Division

PAYROLL

(For Contractor's Optional Use; See Instructions at [www.dol.gov/whd/forms/wh347instr.htm](http://www.dol.gov/whd/forms/wh347instr.htm))



U.S. Wage and Hour Division  
Rev. Dec. 2008

Persons are not required to respond to the collection of information unless it displays a currently valid OMB control number.

OMB No.: 1235-0008  
Expires: 01/31/2015

NAME OF CONTRACTOR  OR SUBCONTRACTOR   
 KORANDO CORPORATION  
 ADDRESS P.O. BOX 20538  
 BARRIGADA, GUAM 96921

PAYROLL NO. 19 (Page 1) FOR WEEK ENDING 05/17/2015  
 PROJECT AND LOCATION Bile/Pigua Bridge Replacement (Construction Phase)  
 Along Route 4, Merizo, Guam PROJECT OR CONTRACT NO. GU-NH-NBIS (007)

(1) NAME AND INDIVIDUAL IDENTIFYING NUMBER (e.g., LAST FOUR DIGITS OF SOCIAL SECURITY NUMBER) OF WORKER	(2) NO. OF WITHHOLDING EXEMPTIONS	(3) WORK CLASSIFICATION	OT OR ST	(4) DAY AND DATE							(5) TOTAL HOURS	(6) RATE OF PAY	(7) GROSS AMOUNT EARNED	(8) DEDUCTIONS					(9) NET WAGES PAID FOR WEEK		
				M	T	W	TH	F	SA	SU				FICA	WITH- HOLDING TAX	D/L	Afac Medical	OTHER		TOTAL DEDUCTIONS	
				11	12	13	14	15	16	17											
Javelosa, Lauro E. P.O. Box 20538 Barrigada, Guam 96921	5139 S	Construction Laborer	O	0.00	0.00	0.00	0.00	0.00	0.00	0.00		\$19.31	\$216.75	\$0.00	\$0.00	\$0.00	\$0.00	\$0.00			
			S	0.00	0.00	0.00	0.00	0.00	0.00	0.00		12.87									
Leg, Kerman P.O. Box 20538 Barrigada, Guam 96921	2346 M	Construction Laborer	O	0.00	0.00	0.00	0.00	0.00	0.00	0.00		\$12.75	\$216.75	\$16.58	\$0.00	\$0.00	\$0.00	\$0.00	\$0.00	\$16.58	\$200.17
			S	8.50	8.50	8.50	0.00	0.00	0.00	0.00		25.50									
Wada, Mallhew P.O. Box 20538 Barrigada, Guam 96921	3262 S	Apprenticeship (Cement Mason)	O	0.00	0.00	0.00	0.00	0.00	0.00	0.00		\$14.48	\$328.10	\$25.11	\$22.00	\$0.00	\$0.00	\$0.00	\$0.00	\$47.11	\$280.99
			S	8.50	8.50	8.50	0.00	0.00	0.00	0.00		34.00									
Munar, Florante (H2-B) P.O. Box 20538 Barrigada, Guam 96921	6711 S	Carpenter	O	0.00	0.00	0.00	0.00	0.00	0.00	0.00		\$20.34	\$461.04	\$0.00	\$42.00	\$35.00	\$0.00	\$0.00	\$0.00	\$77.00	\$384.04
			S	8.50	8.50	8.50	0.00	0.00	0.00	0.00		34.00									
Bansil, Ray P.O. Box 20538 Barrigada, Guam 96921	3135 M	Carpenter	O	0.00	0.00	0.00	0.00	0.00	0.00	0.00		\$21.00	\$357.00	\$31.75	\$2.00	\$0.00	\$53.97	\$0.00	\$0.00	\$87.72	\$381.28
			S	0.00	8.50	8.50	8.50	0.00	0.00	0.00		25.50									
Pascua, Ernesto B. (H2-B) P.O. Box 20538 Barrigada, Guam 96921	5212 S	Heavy Equipment Operator	O	0.00	0.00	0.00	0.00	0.00	0.00	0.00		\$20.66	\$468.18	\$0.00	\$43.00	\$35.00	\$0.00	\$0.00	\$0.00	\$78.00	\$390.18
			S	8.50	8.50	8.50	8.50	0.00	0.00	0.00		34.00									
Bansil, Raul (H2-B) P.O. Box 20538 Barrigada, Guam 96921	8167 S	Cement Mason	O	0.00	0.00	0.00	0.00	0.00	0.00	0.00		\$19.31	\$437.58	\$0.00	\$39.00	\$35.00	\$0.00	\$0.00	\$0.00	\$74.00	\$363.58
			S	8.50	8.50	8.50	8.50	0.00	0.00	0.00		34.00									
Ichin, A.S. P.O. Box 20538 Barrigada, Guam 96921	8409 S	Apprenticeship (Cement Mason)	O	0.00	0.00	0.00	0.00	0.00	0.00	0.00		\$14.48	\$246.08	\$18.81	\$12.00	\$0.00	\$0.00	\$0.00	\$0.00	\$30.81	\$215.27
			S	8.50	8.50	8.50	0.00	0.00	0.00	0.00		25.50									

While completion of Form WH-347 is optional, it is mandatory for covered contractors and subcontractors performing work on Federally financed or assisted construction contracts to respond to the information collection contained in 29 C.F.R. §§ 3.3, 5.5(a). The Copeland Act (40 U.S.C. § 3145) contractors and subcontractors performing work on Federally financed or assisted construction contracts to "furnish weekly a statement with respect to the wages paid each employee during the preceding week." U.S. Department of Labor (DOL) regulations at 29 C.F.R. § 5.5(a)(3)(ii) require contractors to submit weekly a copy of all payrolls to the Federal agency contracting for or financing the construction project, accompanied by a signed "Statement of Compliance" indicating that the payrolls are correct and complete and that each laborer or mechanic has been paid not less than the proper Davis-Bacon prevailing wage rate for the work performed. DOL and federal contracting agencies receiving this information review the information to determine that employees have received legally required wages and fringe benefits.

Public Burden Statement

We estimate that it will take an average of 55 minutes to complete this collection, including time for reviewing instructions, searching existing data sources, gathering and maintaining the data needed, and completing and reviewing the collection of information. If you have any comments regarding these estimates or any other aspect of this collection, including suggestions for reducing this burden, send them to the Administrator, Wage and Hour Division, U.S. Department of Labor, Room S3502, 200 Constitution Avenue, N.W., Washington, D.C. 20210

PAYROLL

(For Contractor's Optional Use; See Instructions at [www.dol.gov/whd/forms/wh347instr.htm](http://www.dol.gov/whd/forms/wh347instr.htm))



Persons are not required to respond to the collection of information unless it displays a currently valid OMB control number.

NAME OF CONTRACTOR <input checked="" type="checkbox"/> OR SUBCONTRACTOR <input type="checkbox"/>		ADDRESS	OMB No.: 1235-0008
KORANDO CORPORATION		P.O. BOX 20538 BARRIGADA, GUAM 96921	Expires: 01/31/2015
PAYROLL NO. 19 (Page 2)	FOR WEEK ENDING 05/17/2015	PROJECT AND LOCATION Bile/Pigua Bridge Replacement (Construction Phase) Along Route 4, Merizo, Guam	PROJECT OR CONTRACT NO. GU-NH-NBIS (007)

(1) NAME AND INDIVIDUAL IDENTIFYING NUMBER (e.g., LAST FOUR DIGITS OF SOCIAL SECURITY NUMBER) OF WORKER	(2) NO. OF WITHHOLDING EXEMPTIONS	(3) WORK CLASSIFICATION	OT. OR ST.	(4) DAY AND DATE							(5) TOTAL HOURS	(6) RATE OF PAY	(7) GROSS AMOUNT EARNED	(8) DEDUCTIONS					(9) NET WAGES PAID FOR WEEK		
				M	T	W	TH	F	SA	SU				FICA	WITH- HOLDING TAX	D/L	Affac Medical	OTHER		TOTAL DEDUCTIONS	
				11	12	13	14	15	16	17											
Bansil, Jesus M. P.O. Box 20538 Barrigada, Guam 96921	9256 M	Cement Mason	O	0.00	0.00	0.00	0.00	0.00	0.00	0.00	0.00	8.50	\$19.31	\$109.40	\$32.01	\$2.00	\$0.00	\$0.00	\$0.00	\$34.01	\$384.27
			S	8.50	0.00	0.00	0.00	0.00	0.00	0.00	8.50	12.87	\$418.28								
			O																		
			S																		
			O																		
			S																		
			O																		
			S																		
			O																		
			S																		
			O																		
			S																		

While completion of Form WH-347 is optional, it is mandatory for covered contractors and subcontractors performing work on Federally financed or assisted construction contracts to respond to the information collection contained in 29 C.F.R. §§ 3.3, 5.5(a). The Copeland Act (40 U.S.C. § 3145) contractors and subcontractors performing work on Federally financed or assisted construction contracts to "furnish weekly a statement with respect to the wages paid each employee during the preceding week." U.S. Department of Labor (DOL) regulations at 29 C.F.R. § 5.5(a)(3)(i) require contractors to submit weekly a copy of all payrolls to the Federal agency contracting for or financing the construction project, accompanied by a signed "Statement of Compliance" indicating that the payrolls are correct and complete and that each laborer or mechanic has been paid not less than the proper Davis-Bacon prevailing wage rate for the work performed. DOL and federal contracting agencies receiving this information review the information to determine that employees have received legally required wages and fringe benefits.

Public Burden Statement

We estimate that it will take an average of 55 minutes to complete this collection, including time for reviewing instructions, searching existing data sources, gathering and maintaining the data needed, and completing and reviewing the collection of information. If you have any comments regarding these estimates or any other aspect of this collection, including suggestions for reducing this burden, send them to the Administrator, Wage and Hour Division, U.S. Department of Labor, Room S3502, 200 Constitution Avenue, N.W., Washington, D.C. 20210



Date 05/21/2015

I, HYON SANG KIM OPERATIONS MANAGER  
(Name of Signatory Party) (Title)

do hereby state:

(1) That I pay or supervise the payment of the persons employed by

KORANDO CORPORATION on the  
(Contractor or Subcontractor)  
380H Harmon Industrial Park, Tamuning, GU; that during the payroll period commencing on the  
(Building or Work)  
11 day of May, 2015, and ending the 17 day of May, 2015

all persons employed on said project have been paid the full weekly wages earned, that no rebates have been or will be made either directly or indirectly to or on behalf of said

KORANDO CORPORATION from the full  
(Contractor or Subcontractor)

weekly wages earned by any person and that no deductions have been made either directly or indirectly from the full wages earned by any person, other than permissible deductions as defined in Regulations, Part 3 (29 C.F.R. Subtitle A), issued by the Secretary of Labor under the Copeland Act, as amended (48 Stat. 948, 63 Stat. 108, 72 Stat. 967; 76 Stat. 357; 40 U.S.C. § 3145), and described below:

\_\_\_\_\_  
\_\_\_\_\_  
\_\_\_\_\_

(2) That any payrolls otherwise under this contract required to be submitted for the above period are correct and complete; that the wage rates for laborers or mechanics contained therein are not less than the applicable wage rates contained in any wage determination incorporated into the contract; that the classifications set forth therein for each laborer or mechanic conform with the work he performed.

(3) That any apprentices employed in the above period are duly registered in a bona fide apprenticeship program registered with a State apprenticeship agency recognized by the Bureau of Apprenticeship and Training, United States Department of Labor, or if no such recognized agency exists in a State, are registered with the Bureau of Apprenticeship and Training, United States Department of Labor.

(4) That:

(a) WHERE FRINGE BENEFITS ARE PAID TO APPROVED PLANS, FUNDS, OR PROGRAMS

- In addition to the basic hourly wage rates paid to each laborer or mechanic listed in the above referenced payroll, payments of fringe benefits as listed in the contract have been or will be made to appropriate programs for the benefit of such employees, except as noted in section 4(c) below.

(b) WHERE FRINGE BENEFITS ARE PAID IN CASH

- Each laborer or mechanic listed in the above referenced payroll has been paid, as indicated on the payroll, an amount not less than the sum of the applicable basic hourly wage rate plus the amount of the required fringe benefits as listed in the contract, except as noted in section 4(c) below.

(c) EXCEPTIONS

EXCEPTION (CRAFT)	EXPLANATION

REMARKS:

NAME AND TITLE Hyon Sang Kim / Operations Manager	SIGNATURE 
THE WILLFUL FALSIFICATION OF ANY OF THE ABOVE STATEMENTS MAY SUBJECT THE CONTRACTOR OR SUBCONTRACTOR TO CIVIL OR CRIMINAL PROSECUTION. SEE SECTION 1001 OF TITLE 18 AND SECTION 231 OF TITLE 31 OF THE UNITED STATES CODE.	





**KORANDO CORPORATION**

**GENERAL CONTRACTOR**

PO BOX 20538 GMF, GUAM 96921

Tel Nos. (671) 649-7880/81 Fax (671) 649-7882

**COPY**

**BILE / FIGUA BRIDGE REPLACEMENT  
(CONSTRUCTION PHASE)  
PROJECT NO.: GU-NH-NBIS (007)**

**CERTIFIED PAYROLL REPORTS  
FOR WEEK ENDING 05-24-2015**

RECEIVED BY C. RICHARDS  
6/2/15 @ WEEKLY MEETING

U.S. Department of Labor  
Wage and Hour Division

PAYROLL

(For Contractor's Optional Use; See Instructions at [www.dol.gov/whd/forms/wh347instr.htm](http://www.dol.gov/whd/forms/wh347instr.htm))



Rev. Dec. 2008

Persons are not required to respond to the collection of information unless it displays a currently valid OMB control number.

OMB No.: 1235-0008  
Expires: 01/31/2015

NAME OF CONTRACTOR <input checked="" type="checkbox"/> OR SUBCONTRACTOR <input type="checkbox"/>		ADDRESS	
KORANDO CORPORATION		P.O. BOX 20538 BARRIGADA, GUAM 96921	
PAYROLL NO. 20 (Page 1)		FOR WEEK ENDING 05/24/2015	PROJECT AND LOCATION Bile/Pigua Bridge Replacement (Construction Phase) Along Route 4, Merizo, Guam
		PROJECT OR CONTRACT NO. GU-NH-NBIS (007)	

(1) NAME AND INDIVIDUAL IDENTIFYING NUMBER (e.g., LAST FOUR DIGITS OF SOCIAL SECURITY NUMBER) OF WORKER	(2) NO. OF WITHHOLDING EXEMPTIONS	(3) WORK CLASSIFICATION	OT ORST	(4) DAY AND DATE							(5) TOTAL HOURS	(6) RATE OF PAY	(7) GROSS AMOUNT EARNED	(8) DEDUCTIONS					(9) NET WAGES PAID FOR WEEK	
				M	T	W	TH	F	SA	SU				FICA	WITH- HOLDING TAX	D/L	Affac Medical	OTHER		TOTAL DEDUCTIONS
				18	19	20	21	22	23	24										
Javelosa, Lauro E. P.O. Box 20538 Barrigada, Guam 96921	5139 S	Construction Laborer	D	0.00	0.00	0.00	0.00	0.00	0.00	0.00		\$19.31	\$0.00	\$0.00	\$0.00	\$0.00	\$0.00			
				S	0.00	0.00	0.00	0.00	0.00	0.00	0.00								12.87	
Leg, Kerman P.O. Box 20538 Barrigada, Guam 96921	2346 M	Construction Laborer	D	0.00	0.00	0.00	0.00	2.50	0.00	0.00	2.50	\$12.75	\$371.88	\$28.44	\$13.00	\$0.00	\$0.00	\$0.00	\$41.44	\$330.44
				S	8.50	8.50	8.50	8.50	6.00	0.00	0.00	40.00	8.50							
Wada, Matthew P.O. Box 20538 Barrigada, Guam 96921	3262 S	Apprenticeship (Cement Mason)	D	0.00	0.00	0.00	0.00	2.50	0.00	0.00	2.50	\$14.48	\$422.20	\$32.29	\$36.00	\$0.00	\$0.00	\$0.00	\$68.29	\$353.91
				S	8.50	8.50	8.50	8.50	6.00	0.00	0.00	40.00	9.65							
Munar, Florante (H2-B) P.O. Box 20538 Barrigada, Guam 96921	6711 S	Carpenter	D	0.00	0.00	0.00	0.00	2.50	0.00	0.00	2.50	\$20.34	\$593.25	\$0.00	\$62.00	\$35.00	\$0.00	\$0.00	\$97.00	\$496.25
				S	6.50	8.50	8.50	8.50	6.00	0.00	0.00	40.00	13.56							
Bansil, Ray P.O. Box 20538 Barrigada, Guam 96921	3135 M	Carpenter	D	0.00	0.00	0.00	0.00	2.50	0.00	0.00	2.50	\$21.00	\$612.50	\$55.57	\$33.00	\$0.00	\$53.97	\$0.00	\$142.54	\$637.96
				S	8.50	8.50	8.50	8.50	6.00	0.00	0.00	40.00	14.00							
Pascua, Ernesto B. (H2-B) P.O. Box 20538 Barrigada, Guam 96921	5212 S	Heavy Equipment Operator	D	0.00	0.00	0.00	0.00	2.50	0.00	0.00	2.50	\$20.66	\$602.45	\$0.00	\$63.00	\$35.00	\$0.00	\$0.00	\$98.00	\$504.45
				S	8.50	8.50	8.50	8.50	6.00	0.00	0.00	40.00	13.77							
Bansil, Raul (H2-B) P.O. Box 20538 Barrigada, Guam 96921	8167 S	Cement Mason	D	0.00	0.00	0.00	0.00	2.50	0.00	0.00	2.50	\$19.31	\$563.08	\$0.00	\$57.00	\$35.00	\$0.00	\$0.00	\$92.00	\$471.08
				S	8.50	8.50	8.50	8.50	6.00	0.00	0.00	40.00	12.87							
Ichin, A.S. P.O. Box 20538 Barrigada, Guam 96921	8409 S	Apprenticeship (Cement Mason)	D	0.00	0.00	0.00	0.00	0.00	0.00	0.00		\$14.48	\$246.08	\$18.83	\$12.00	\$0.00	\$0.00	\$0.00	\$30.83	\$215.25
				S	8.50	8.50	0.00	8.50	0.00	0.00	0.00	25.50	9.65							

While completion of Form WH-347 is optional, it is mandatory for covered contractors and subcontractors performing work on Federally financed or assisted construction contracts to respond to the information collection contained in 29 C.F.R. §§ 3.3, 5.5(a). The Copeland Act (40 U.S.C. § 3145) contractors and subcontractors performing work on Federally financed or assisted construction contracts to "furnish weekly a statement with respect to the wages paid each employee during the preceding week." U.S. Department of Labor (DOL) regulations at 29 C.F.R. § 5.5(a)(3)(ii) require contractors to submit weekly a copy of all payrolls to the Federal agency contracting for or financing the construction project, accompanied by a signed "Statement of Compliance" indicating that the payrolls are correct and complete and that each laborer or mechanic has been paid not less than the proper Davis-Bacon prevailing wage rate for the work performed. DOL and federal contracting agencies receiving this information review the information to determine that employees have received legally required wages and fringe benefits.

Public Burden Statement

We estimate that it will take an average of 55 minutes to complete this collection, including time for reviewing instructions, searching existing data sources, gathering and maintaining the data needed, and completing and reviewing the collection of information. If you have any comments regarding these estimates or any other aspect of this collection, including suggestions for reducing this burden, send them to the Administrator, Wage and Hour Division, U.S. Department of Labor, Room S3502, 200 Constitution Avenue, N.W. Washington, D.C. 20210









**KORANDO CORPORATION**  
**GENERAL CONTRACTOR**  
PO BOX 20538 GMF, GUAM 96921  
Tel Nos. (671) 649-7880/81 Fax (671) 649-7882

**COPY**

**BILE / PIGUA BRIDGE REPLACEMENT  
(CONSTRUCTION PHASE)  
PROJECT NO.: GU-NH-NBIS (007)**

**CERTIFIED PAYROLL REPORTS  
FOR WEEK ENDING 05-31-2015**

  
Stanley Consultants Inc.  
  
Signature  
6-11-15  
10-23

U.S. Department of Labor  
Wage and Hour Division

PAYROLL

(For Contractor's Optional Use; See Instructions at [www.dol.gov/whd/forms/wh347instr.htm](http://www.dol.gov/whd/forms/wh347instr.htm))

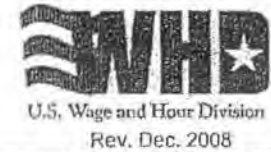

Persons are not required to respond to the collection of information unless it displays a currently valid OMB control number.

NAME OF CONTRACTOR <input checked="" type="checkbox"/> OR SUBCONTRACTOR <input type="checkbox"/>	ADDRESS	OMB No.: 1235-0008 Expires: 01/31/2015
KORANDO CORPORATION	P.O. BOX 20538 BARRIGADA, GUAM 96921	
PAYROLL NO. 21	FOR WEEK ENDING 05/31/2015	PROJECT OR CONTRACT NO. GU-NH-NBIS (007)
PROJECT AND LOCATION Bile/Pigua Bridge Replacement (Construction Phase) Along Route 4, Merizo, Guam		

(1) NAME AND INDIVIDUAL IDENTIFYING NUMBER (e.g., LAST FOUR DIGITS OF SOCIAL SECURITY NUMBER) OF WORKER	(2) NO. OF WITHHOLDING EXEMPTIONS	(3) WORK CLASSIFICATION	(4) DAY AND DATE							(5) TOTAL HOURS	(6) RATE OF PAY	(7) GROSS AMOUNT EARNED	(8) DEDUCTIONS					(9) NET WAGES PAID FOR WEEK		
			OT OR ST	M	T	W	TH	F	SA				SU	FICA	WITH- HOLDING TAX	D/L	A/Inc Medical		OTHER	TOTAL DEDUCTIONS
				25	26	27	28	29	30				31							
Javelosa, Lauro E. P.O. Box 20538 Barrigada, Guam 96921	5139 S	Construction Laborer	O	0.00	0.00	0.00	0.00	0.00	0.00	0.00		\$19.31	\$109.40	\$40.13	\$52.00	\$35.00	\$0.00	\$0.00	\$127.13	\$397.34
			S	0.00	0.00	3.50	0.00	0.00	0.00	0.00	8.50	12.87	\$524.47							
Leg, Kerman P.O. Box 20538 Barrigada, Guam 96921	2346 M	Construction Laborer	O	0.00	0.00	0.00	0.00	0.00	0.00	0.00		\$12.75	\$216.75	\$21.79	\$4.00	\$0.00	\$0.00	\$0.00	\$25.79	\$258.96
			S	0.00	0.50	0.00	0.50	0.50	0.00	0.00	25.50	0.50	\$284.75							
Wada, Mathew P.O. Box 20538 Barrigada, Guam 96921	3262 S	Apprenticeship (Cement Mason)	O	0.00	0.00	0.00	0.00	0.00	0.00	0.00		\$14.48	\$328.10	\$31.75	\$35.00	\$0.00	\$0.00	\$0.00	\$66.75	\$348.21
			S	0.00	0.50	0.50	0.50	0.50	0.00	0.00	34.00	9.65	\$414.96							
Munar, Florante (H2-B) P.O. Box 20538 Barrigada, Guam 96921	8711 S	Carpenter	O	0.00	0.00	0.00	0.00	0.00	0.00	0.00		\$20.34	\$461.04	\$0.00	\$60.00	\$35.00	\$0.00	\$0.00	\$95.00	\$488.08
			S	0.00	3.50	1.50	3.50	3.50	0.00	0.00	34.00	13.56	\$583.08							
Bansil, Ray P.O. Box 20538 Barrigada, Guam 96921	3135 M	Carpenter	O	0.00	0.00	0.00	0.00	0.00	0.00	0.00		\$21.00	\$476.00	\$54.79	\$32.00	\$0.00	\$53.97	\$0.00	\$140.76	\$629.24
			S	0.00	0.50	0.50	0.50	0.50	0.00	0.00	34.00	14.00	\$770.00							
Pascua, Ernesto B. (H2-B) P.O. Box 20538 Barrigada, Guam 96921	5212 S	Heavy Equipment Operator	O	0.00	0.00	0.00	0.00	0.00	0.00	0.00		\$20.66	\$468.18	\$0.00	\$62.00	\$35.00	\$0.00	\$0.00	\$97.00	\$495.12
			S	0.00	0.50	0.50	0.50	0.50	0.00	0.00	34.00	13.77	\$592.12							
Bansil, Raul (H2-B) P.O. Box 20538 Barrigada, Guam 96921	8167 S	Cement Mason	O	0.00	0.00	0.00	0.00	0.00	0.00	0.00		\$19.31	\$437.58	\$0.00	\$56.00	\$35.00	\$0.00	\$0.00	\$91.00	\$462.42
			S	0.00	0.50	0.50	0.50	0.50	0.00	0.00	34.00	12.87	\$553.42							
Ichin, A.S. P.O. Box 20538 Barrigada, Guam 96921	8409 S	Apprenticeship (Cement Mason)	O	0.00	0.00	0.00	0.00	0.00	0.00	0.00		\$14.48	\$246.08	\$24.73	\$21.00	\$0.00	\$0.00	\$0.00	\$45.73	\$277.55
			S	0.00	0.50	0.00	0.50	0.50	0.00	0.00	25.50	9.65	\$323.28							

While completion of Form WH-347 is optional, it is mandatory for covered contractors and subcontractors performing work on Federally financed or assisted construction contracts to respond to the information collection contained in 29 C.F.R. §§ 3.3, 5.5(a). The Copeland Act (40 U.S.C. § 3145) contractors and subcontractors performing work on Federally financed or assisted construction contracts to "furnish weekly a statement with respect to the wages paid each employee during the preceding week." U.S. Department of Labor (DOL) regulations at 29 C.F.R. § 5.5(a)(3)(ii) require contractors to submit weekly a copy of all payrolls to the Federal agency contracting for or financing the construction project, accompanied by a signed "Statement of Compliance" indicating that the payrolls are correct and complete and that each laborer or mechanic has been paid not less than the proper Davis-Bacon prevailing wage rate for the work performed. DOL and Federal contracting agencies receiving this information review the information to determine that employees have received legally required wages and fringe benefits.

Public Burden Statement

We estimate that it will take an average of 55 minutes to complete this collection, including time for reviewing instructions, searching existing data sources, gathering and maintaining the data needed, and completing and reviewing the collection of information. If you have any comments regarding these estimates or any other aspect of this collection, including suggestions for reducing this burden, send them to the Administrator, Wage and Hour Division, U.S. Department of Labor, Room S3502, 200 Constitution Avenue, N.W., Washington, D.C. 20210



Date 06/11/2015

I, HYON SANG KIM OPERATIONS MANAGER  
(Name of Signatory Party) (Title)

do hereby state:

(1) That I pay or supervise the payment of the persons employed by

KORANDO CORPORATION on the  
(Contractor or Subcontractor)

380H Harmon Industrial Park, Tamuning, GU; that during the payroll period commencing on the  
(Building or Work)

25 day of May, 2015, and ending the 31 day of May, 2015,

all persons employed on said project have been paid the full weekly wages earned, that no rebates have been or will be made either directly or indirectly to or on behalf of said

KORANDO CORPORATION from the full  
(Contractor or Subcontractor)

weekly wages earned by any person and that no deductions have been made either directly or indirectly from the full wages earned by any person, other than permissible deductions as defined in Regulations, Part 3 (29 C.F.R. Subtitle A), issued by the Secretary of Labor under the Copeland Act, as amended (48 Stat. 948, 63 Stat. 108, 72 Stat. 967; 76 Stat. 357; 40 U.S.C. § 3145), and described below:

\_\_\_\_\_  
\_\_\_\_\_  
\_\_\_\_\_  
\_\_\_\_\_

(2) That any payrolls otherwise under this contract required to be submitted for the above period are correct and complete; that the wage rates for laborers or mechanics contained therein are not less than the applicable wage rates contained in any wage determination incorporated into the contract; that the classifications set forth therein for each laborer or mechanic conform with the work he performed.

(3) That any apprentices employed in the above period are duly registered in a bona fide apprenticeship program registered with a State apprenticeship agency recognized by the Bureau of Apprenticeship and Training, United States Department of Labor, or if no such recognized agency exists in a State, are registered with the Bureau of Apprenticeship and Training, United States Department of Labor.

(4) That:

(a) WHERE FRINGE BENEFITS ARE PAID TO APPROVED PLANS, FUNDS, OR PROGRAMS

- in addition to the basic hourly wage rates paid to each laborer or mechanic listed in the above referenced payroll, payments of fringe benefits as listed in the contract have been or will be made to appropriate programs for the benefit of such employees, except as noted in section 4(c) below.

(b) WHERE FRINGE BENEFITS ARE PAID IN CASH

- Each laborer or mechanic listed in the above referenced payroll has been paid, as indicated on the payroll, an amount not less than the sum of the applicable basic hourly wage rate plus the amount of the required fringe benefits as listed in the contract, except as noted in section 4(c) below.

(c) EXCEPTIONS

EXCEPTION (CRAFT)	EXPLANATION

REMARKS:

NAME AND TITLE  
Hyon Sang Kim / Operations Manager

SIGNATURE  
for: 

THE WILLFUL FALSIFICATION OF ANY OF THE ABOVE STATEMENTS MAY SUBJECT THE CONTRACTOR OR SUBCONTRACTOR TO CIVIL OR CRIMINAL PROSECUTION. SEE SECTION 1001 OF TITLE 18 AND SECTION 231 OF TITLE 31 OF THE UNITED STATES CODE.





**KORANDO CORPORATION**  
**GENERAL CONTRACTOR**  
PO BOX 20538 GMF, GUAM 96921  
Tel Nos. (671) 649-7880/81 Fax (671) 649-7882

**COPY**

**BILE / PIGUA BRIDGE REPLACEMENT  
(CONSTRUCTION PHASE)  
PROJECT NO.: GU-NH-NBIS (007)**

**CERTIFIED PAYROLL REPORTS  
FOR WEEK ENDING 06-07-2015**

  
Stanley Consultants Inc.  
*[Signature]* 6-11-15  
1023

PAYROLL

(For Contractor's Optional Use; See Instructions at [www.dol.gov/whd/forms/wh347instr.htm](http://www.dol.gov/whd/forms/wh347instr.htm))

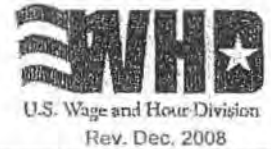

Persons are not required to respond to the collection of information unless it displays a currently valid OMB control number.

Rev. Dec. 2008  
OMB No.: 1235-0008  
Expires: 01/31/2015

NAME OF CONTRACTOR <input checked="" type="checkbox"/> OR SUBCONTRACTOR <input type="checkbox"/>		ADDRESS	
KORANDO CORPORATION		P.O. BOX 20538 BARRIGADA, GUAM 96921	
PAYROLL NO. 22	FOR WEEK ENDING 06/07/2015	PROJECT AND LOCATION Bile/Pigua Bridge Replacement (Construction Phase) Along Route 4, Merizo, Guam	PROJECT OR CONTRACT NO. GU-NH-NBIS (007)

(1) NAME AND INDIVIDUAL IDENTIFYING NUMBER (e.g., LAST FOUR DIGITS OF SOCIAL SECURITY NUMBER) OF WORKER	(2) NO. OF WITHHOLDING EXEMPTIONS	(3) WORK CLASSIFICATION	(4) DAY AND DATE							(5) TOTAL HOURS	(6) RATE OF PAY	(7) GROSS AMOUNT EARNED	(8) DEDUCTIONS					(9) NET WAGES PAID FOR WEEK		
			DT. OR FT.	M	T	W	TH	F	SA				SU	FICA	WITH-HOLDING TAX	D/L	Affil Medical		OTHER	TOTAL DEDUCTIONS
				1	2	3	4	5	6				7							
Javelosa, Lauro E. P.O. Box 20538 Barrigada, Guam 96921 5139 S	1	Construction Laborer	O	0.00	0.00	0.00	0.00	0.00	0.00	0.00	0.00	\$19.31	\$0.00	\$0.00	\$0.00	\$0.00	\$0.00			
			S	0.00	0.00	0.00	0.00	0.00	0.00	0.00	0.00	12.87								
Leg, Kerman P.O. Box 20538 Barrigada, Guam 96921 2346 M	1	Construction Laborer	O	0.00	0.50	0.00	0.00	0.00	0.00	0.00	0.00	\$12.75	\$259.25	\$25.03	\$8.00	\$0.00	\$0.00	\$0.00	\$33.03	\$294.22
			S	0.00	8.50	8.50	5.00	5.50	0.00	0.00	30.50	8.50								
Wada, Matthew P.O. Box 20538 Barrigada, Guam 96921 3262 S	1	Apprenticeship (Cement Mason)	O	0.00	0.00	0.00	0.00	0.00	0.00	0.00	0.00	\$14.48	\$342.58	\$33.40	\$38.00	\$0.00	\$0.00	\$0.00	\$71.40	\$365.29
			S	8.50	5.00	8.50	5.00	8.50	0.00	0.00	35.50	9.65								
Munar, Florante (H2-B) P.O. Box 20538 Barrigada, Guam 96921 6711 S	1	Carpenter	O	0.00	0.00	0.00	0.00	0.00	0.00	0.00	0.00	\$20.34	\$528.84	\$0.00	\$52.00	\$35.00	\$0.00	\$0.00	\$87.00	\$441.84
			S	8.50	8.50	8.50	5.00	8.50	0.00	0.00	39.00	13.56								
Bansil, Ray P.O. Box 20538 Barrigada, Guam 96921 3135 M	3	Carpenter	O	0.00	0.00	0.00	0.00	0.00	0.00	0.00	0.00	\$21.00	\$546.00	\$37.63	\$10.00	\$0.00	\$53.97	\$0.00	\$101.60	\$444.40
			S	8.50	8.50	8.50	5.00	8.50	0.00	0.00	39.00	14.00								
Pascua, Ernesto B. (H2-B) P.O. Box 20538 Barrigada, Guam 96921 5212 S	1	Heavy Equipment Operator	O	0.00	0.00	0.00	0.00	0.00	0.00	0.00	0.00	\$20.66	\$537.03	\$0.00	\$70.00	\$35.00	\$0.00	\$0.00	\$105.00	\$538.77
			S	8.50	8.50	8.50	5.00	8.50	0.00	0.00	39.00	13.77								
Bansil, Raul (H2-B) P.O. Box 20538 Barrigada, Guam 96921 8167 S	1	Cement Mason	O	0.00	0.00	0.00	0.00	0.00	0.00	0.00	0.00	\$19.31	\$501.93	\$0.00	\$63.00	\$35.00	\$0.00	\$0.00	\$98.00	\$503.70
			S	8.50	8.50	8.50	5.00	8.50	0.00	0.00	39.00	12.87								
Ichin, A.S. P.O. Box 20538 Barrigada, Guam 96921 8409 S	1	Apprenticeship (Cement Mason)	O	0.00	0.00	0.00	0.00	0.00	0.00	0.00	0.00	\$14.48	\$294.33	\$28.43	\$29.00	\$0.00	\$0.00	\$0.00	\$57.43	\$314.10
			S	0.00	8.50	8.50	5.00	8.50	0.00	0.00	30.50	9.65								

While completion of Form WH-347 is optional, it is mandatory for covered contractors and subcontractors performing work on Federally financed or assisted construction contracts to respond to the information collection contained in 29 C.F.R. §§ 3.3, 5.5(a). The Copeland Act (40 U.S.C. § 3145) contractors and subcontractors performing work on Federally financed or assisted construction contracts to "furnish weekly a statement with respect to the wages paid each employee during the preceding week." U.S. Department of Labor (DOL) regulations at 29 C.F.R. § 5.5(a)(3)(ii) require contractors to submit weekly a copy of all payrolls to the Federal agency contracting for or financing the construction project, accompanied by a signed "Statement of Compliance" indicating that the payrolls are correct and complete and that each laborer or mechanic has been paid not less than the proper Davis-Bacon prevailing wage rate for the work performed. DOL and federal contracting agencies receiving this information review the information to determine that employees have received legally required wages and fringe benefits.

Public Burden Statement

We estimate that it will take an average of 55 minutes to complete this collection, including time for reviewing instructions, searching existing data sources, gathering and maintaining the data needed, and completing and reviewing the collection of information. If you have any comments regarding these estimates or any other aspect of this collection, including suggestions for reducing this burden, send them to the Administrator, Wage and Hour Division, U.S. Department of Labor, Room 53502, 200 Constitution Avenue, N.W. Washington, D.C. 20210



Date 06/11/2015

I, HYON SANG KIM OPERATIONS MANAGER  
(Name of Signatory Party) (Title)

do hereby state:

(1) That I pay or supervise the payment of the persons employed by

KORANDO CORPORATION of the  
(Contractor or Subcontractor)

380H Harmon Industrial Park, Tamuning, GU, that during the payroll period commencing on the  
(Building or Work)

01 day of June, 2015, and ending the 07 day of June, 2015,

all persons employed on said project have been paid the full weekly wages earned, that no rebates have been or will be made either directly or indirectly to or on behalf of said

KORANDO CORPORATION from the full  
(Contractor or Subcontractor)

weekly wages earned by any person and that no deductions have been made either directly or indirectly from the full wages earned by any person, other than permissible deductions as defined in Regulations, Part 3 (29 C.F.R. Subtitle A), issued by the Secretary of Labor under the Copeland Act, as amended (48 Stat. 948, 63 Stat. 108, 72 Stat. 867; 76 Stat. 357; 40 U.S.C. § 3145), and described below:

\_\_\_\_\_  
\_\_\_\_\_  
\_\_\_\_\_

(2) That any payrolls otherwise under this contract required to be submitted for the above period are correct and complete; that the wage rates for laborers or mechanics contained therein are not less than the applicable wage rates contained in any wage determination incorporated into the contract; that the classifications set forth therein for each laborer or mechanic conform with the work he performed.

(3) That any apprentices employed in the above period are duly registered in a bona fide apprenticeship program registered with a State apprenticeship agency recognized by the Bureau of Apprenticeship and Training, United States Department of Labor, or if no such recognized agency exists in a State, are registered with the Bureau of Apprenticeship and Training, United States Department of Labor.

(4) That

(a) WHERE FRINGE BENEFITS ARE PAID TO APPROVED PLANS, FUNDS, OR PROGRAMS

- in addition to the basic hourly wage rates paid to each laborer or mechanic listed in the above referenced payroll, payments of fringe benefits as listed in the contract have been or will be made to appropriate programs for the benefit of such employees, except as noted in section 4(c) below.

(b) WHERE FRINGE BENEFITS ARE PAID IN CASH

- Each laborer or mechanic listed in the above referenced payroll has been paid, as indicated on the payroll, an amount not less than the sum of the applicable basic hourly wage rate plus the amount of the required fringe benefits as listed in the contract, except as noted in section 4(c) below.

(c) EXCEPTIONS

EXCEPTION (CRAFT)	EXPLANATION

REMARKS:

NAME AND TITLE  
Hyon Sang Kim / Operations Manager

SIGNATURE  

THE WILLFUL FALSIFICATION OF ANY OF THE ABOVE STATEMENTS MAY SUBJECT THE CONTRACTOR OR SUBCONTRACTOR TO CIVIL OR CRIMINAL PROSECUTION. SEE SECTION 1001 OF TITLE 18 AND SECTION 231 OF TITLE 31 OF THE UNITED STATES CODE.





**KORANDO CORPORATION**  
**GENERAL CONTRACTOR**  
PO BOX 20538 GMF, GUAM 96921  
Tel Nos. (671) 649-7880/81 Fax (671) 649-7882

**COPY**

**BILE / PIGUA BRIDGE REPLACEMENT  
(CONSTRUCTION PHASE)  
PROJECT NO.: GU-NH-NBIS (007)**

**CERTIFIED PAYROLL REPORTS  
FOR WEEK ENDING 06-14-2015**

  
Stanley Consultants Inc.  
*[Signature]*      6.22.15  
Signature      Date *[Initials]*

PAYROLL

(For Contractor's Optional Use; See Instructions at [www.dol.gov/whd/forms/wh347instr.htm](http://www.dol.gov/whd/forms/wh347instr.htm))



Persons are not required to respond to the collection of information unless it displays a currently valid OMB control number.

NAME OF CONTRACTOR  OR SUBCONTRACTOR   
 KORANDO CORPORATION  
 ADDRESS P.O. BOX 20538  
 BARRIGADA, GUAM 96921

PAYROLL NO. 23 FOR WEEK ENDING 06/14/2015  
 PROJECT AND LOCATION Bile/Pigua Bridge Replacement (Construction Phase)  
 Along Route 4, Merizo, Guam PROJECT OR CONTRACT NO. GU-NH-NBIS (007)

(1) NAME AND INDIVIDUAL IDENTIFYING NUMBER (e.g. LAST FOUR DIGITS OF SOCIAL SECURITY NUMBER) OF WORKER	(2) NO. OF WITHHOLDING EXEMPTIONS	(3) WORK CLASSIFICATION	OT. OR ST.	(4) DAY AND DATE							(5) TOTAL HOURS	(6) RATE OF PAY	(7) GROSS AMOUNT EARNED	(8) DEDUCTIONS					(9) NET WAGES PAID FOR WEEK	
				M	T	W	TH	F	SA	SU				FICA	WITH- HOLDING TAX	D/L	Affec Medical	OTHER		TOTAL DEDUCTIONS
				8	9	10	11	12	13	14										
Javelosa, Lauro E. P.O. Box 20538 Barrigada, Guam 96921	5139 S	Construction Laborer	O	0.00	0.00	0.00	0.00	0.00	0.00	0.00	0.00	0.00	\$19.31	\$0.00	\$0.00	\$0.00	\$0.00	\$0.00		
			S	0.00	0.00	0.00	0.00	0.00	0.00	0.00	12.87	\$0.00								
Leg, Kerman P.O. Box 20538 Barrigada, Guam 96921	2346 M	Construction Laborer	O	0.00	0.00	0.00	0.00	0.00	0.24	0.00	0.00	\$12.75	\$332.52	\$25.44	\$9.00	\$0.00	\$0.00	\$0.00	\$34.44	\$298.08
			S	0.00	8.50	8.50	8.50	8.50	0.00	0.00	34.00	9.78	\$332.52							
Wada, Matthew P.O. Box 20538 Barrigada, Guam 96921	3262 S	Apprenticeship (Cement Mason)	O	0.00	0.00	0.00	0.00	2.50	0.00	0.00	2.50	\$14.48	\$422.20	\$34.52	\$41.00	\$0.00	\$0.00	\$0.00	\$75.52	\$375.64
			S	8.50	8.50	8.50	8.50	6.00	0.00	0.00	40.00	9.65	\$451.16							
Munar, Florante (H2-B) P.O. Box 20538 Barrigada, Guam 96921	6711 S	Carpenter	O	0.00	0.00	0.00	0.00	2.50	0.00	0.00	2.50	\$20.34	\$593.25	\$0.00	\$62.00	\$35.00	\$0.00	\$0.00	\$97.00	\$496.25
			S	8.50	8.50	8.50	8.50	6.00	0.00	0.00	40.00	13.56	\$593.25							
Bansil, Ray P.O. Box 20538 Barrigada, Guam 96921	3135 M	Carpenter	O	0.00	0.00	0.00	0.00	2.50	0.00	0.00	2.50	\$21.00	\$612.50	\$55.58	\$33.00	\$0.00	\$53.97	\$0.00	\$142.55	\$637.95
			S	8.50	8.50	8.50	8.50	6.00	0.00	0.00	40.00	14.00	\$780.50							
Pascua, Ernesto B. (H2-B) P.O. Box 20538 Barrigada, Guam 96921	5212 S	Heavy Equipment Operator	O	0.00	0.00	0.00	0.00	2.50	0.00	0.00	2.50	\$20.66	\$602.45	\$0.00	\$63.00	\$35.00	\$0.00	\$0.00	\$98.00	\$504.45
			S	8.50	8.50	8.50	8.50	6.00	0.00	0.00	40.00	13.77	\$602.45							
Bansil, Raul (H2-B) P.O. Box 20538 Barrigada, Guam 96921	8167 S	Cement Mason	O	0.00	0.00	0.00	0.00	2.50	0.00	0.00	2.50	\$19.31	\$563.08	\$0.00	\$57.00	\$35.00	\$0.00	\$0.00	\$92.00	\$471.08
			S	8.50	8.50	8.50	8.50	6.00	0.00	0.00	40.00	12.87	\$563.08							
Ichin, A.S. P.O. Box 20538 Barrigada, Guam 96921	8409 S	Apprenticeship (Cement Mason)	O	0.00	0.00	0.00	0.00	0.00	0.20	0.00	0.20	\$14.48	\$246.08	\$18.82	\$12.00	\$0.00	\$0.00	\$0.00	\$30.82	\$215.26
			S	0.00	0.00	8.50	8.50	8.50	0.00	0.00	25.50	9.65	\$246.08							

While completion of Form WH-347 is optional, it is mandatory for covered contractors and subcontractors performing work on Federally financed or assisted construction contracts to respond to the information collection contained in 29 C.F.R. §§ 3.3, 5.5(a), The Copeland Act (40 U.S.C. § 3145) contractors and subcontractors performing work on Federally financed or assisted construction contracts to "furnish weekly a statement with respect to the wages paid each employee during the preceding week." U.S. Department of Labor (DOL) regulations at 29 C.F.R. § 5.5(a)(3)(ii) require contractors to submit weekly a copy of all payrolls to the Federal agency contracting for or financing the construction project, accompanied by a signed "Statement of Compliance" indicating that the payrolls are correct and complete and that each laborer or mechanic has been paid not less than the proper Davis-Bacon prevailing wage rate for the work performed. DOL and federal contracting agencies receiving this information review the information to determine that employees have received legally required wages and fringe benefits.

Public Burden Statement

We estimate that it will take an average of 55 minutes to complete this collection, including time for reviewing instructions, searching existing data sources, gathering and maintaining the data needed, and completing and reviewing the collection of information. If you have any comments regarding these estimates or any other aspect of this collection, including suggestions for reducing this burden, send them to the Administrator, Wage and Hour Division, U.S. Department of Labor, Room S3502, 200 Constitution Avenue, N.W., Washington, D.C. 20210



Date 06/18/2015

I, HYON SANG KIM OPERATIONS MANAGER  
(Name of Signatory Party) (Title)

do hereby state:

(1) That I pay or supervise the payment of the persons employed by

KORANDO CORPORATION on the  
(Contractor or Subcontractor)  
380H Harmon Industrial Park, Tamuning, GU; that during the payroll period commencing on the  
(Building or Work)

08 day of June, 2015, and ending the 14 day of June, 2015,

all persons employed on said project have been paid the full weekly wages earned, that no rebates have been or will be made either directly or indirectly to or on behalf of said

KORANDO CORPORATION from the full  
(Contractor or Subcontractor)

weekly wages earned by any person and that no deductions have been made either directly or indirectly from the full wages earned by any person, other than permissible deductions as defined in Regulations, Part 3 (29 C.F.R. Subtitle A), issued by the Secretary of Labor under the Copeland Act, as amended (48 Stat. 948, 63 Stat. 108, 72 Stat. 967; 76 Stat. 357; 40 U.S.C. § 3145), and described below:

\_\_\_\_\_  
\_\_\_\_\_  
\_\_\_\_\_  
\_\_\_\_\_

(2) That any payrolls otherwise under this contract required to be submitted for the above period are correct and complete; that the wage rates for laborers or mechanics contained therein are not less than the applicable wage rates contained in any wage determination incorporated into the contract; that the classifications set forth therein for each laborer or mechanic conform with the work he performed.

(3) That any apprentices employed in the above period are duly registered in a bona fide apprenticeship program registered with a State apprenticeship agency recognized by the Bureau of Apprenticeship and Training, United States Department of Labor, or if no such recognized agency exists in a State, are registered with the Bureau of Apprenticeship and Training, United States Department of Labor.

(4) That

(a) WHERE FRINGE BENEFITS ARE PAID TO APPROVED PLANS, FUNDS, OR PROGRAMS

- in addition to the basic hourly wage rates paid to each laborer or mechanic listed in the above referenced payroll, payments of fringe benefits as listed in the contract have been or will be made to appropriate programs for the benefit of such employees, except as noted in section 4(c) below.

(b) WHERE FRINGE BENEFITS ARE PAID IN CASH

- Each laborer or mechanic listed in the above referenced payroll has been paid, as indicated on the payroll, an amount not less than the sum of the applicable basic hourly wage rate plus the amount of the required fringe benefits as listed in the contract, except as noted in section 4(c) below.

(c) EXCEPTIONS

EXCEPTION (CRAFT)	EXPLANATION

REMARKS:

NAME AND TITLE Hyon Sang Kim / Operations Manager	SIGNATURE 
THE WILLFUL FALSIFICATION OF ANY OF THE ABOVE STATEMENTS MAY SUBJECT THE CONTRACTOR OR SUBCONTRACTOR TO CIVIL OR CRIMINAL PROSECUTION. SEE SECTION 1001 OF TITLE 18 AND SECTION 231 OF TITLE 31 OF THE UNITED STATES CODE.	







**KORANDO CORPORATION**  
**GENERAL CONTRACTOR**  
PO BOX 20538 GMF, GUAM 96921  
Tel Nos. (671) 649-7880/81 Fax (671) 649-7882

**COPY**

**BILE / PIGUA BRIDGE REPLACEMENT  
(CONSTRUCTION PHASE)  
PROJECT NO.: GU-NH-NBIS (007)**

**CERTIFIED PAYROLL REPORTS  
FOR WEEK ENDING 04-19-2015**

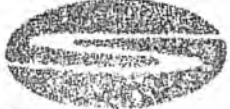
- Pascua, Ernesto B. (included)

  
Stanley Consultants Inc.  
  
Signature  
6-22-15  
Date 8/5

PAYROLL

(For Contractor's Optional Use; See Instructions at [www.dol.gov/whd/forms/wh347instr.htm](http://www.dol.gov/whd/forms/wh347instr.htm))

Persons are not required to respond to the collection of information unless it displays a currently valid OMB control number.

NAME OF CONTRACTOR  OR SUBCONTRACTOR  ADDRESS P.O. BOX 20538  
KORANDO CORPORATION BARRIGADA, GUAM 96921 OMB No.: 1235-0008  
Expires: 01/31/2015

PAYROLL NO. 15A FOR WEEK ENDING 04/19/2015 PROJECT AND LOCATION Bile/Pigua Bridge Replacement (Construction Phase) PROJECT OR CONTRACT NO. GU-NH-NBIS (007)  
Along Route 4, Merizo, Guam

(1) NAME AND INDIVIDUAL IDENTIFYING NUMBER (e.g., LAST FOUR DIGITS OF SOCIAL SECURITY NUMBER) OF WORKER	(2) NO. OF WITHHOLDING EXEMPTIONS	(3) WORK CLASSIFICATION	O.T. OR S.T.	(4) DAY AND DATE							(5) TOTAL HOURS	(6) RATE OF PAY	(7) GROSS AMOUNT EARNED	(8) DEDUCTIONS					(9) NET WAGES PAID FOR WEEK	
				M	T	W	TH	F	SA	SU				FICA	WITH- HOLDING TAX	W/L	Affac Medical	OTHER		TOTAL DEDUCTIONS
				13	14	15	16	17	18	19										
Javelosa, Lauro E. P.O. Box 20538 Barrigada, Guam 96921	5139 S	Construction Laborer	O	0.00	0.00	0.00	0.00	2.50	0.00	0.00	2.50	\$19.31	\$563.08	\$43.07	\$57.00	\$35.00	\$0.00	\$0.00	\$135.07	\$428.01
			S	8.50	8.50	8.50	8.50	6.00	0.00	0.00	40.00	12.87	\$563.08							
Leg, Kerman P.O. Box 20538 Barrigada, Guam 96921	2346 M	Construction Laborer	O	0.00	0.00	0.00	0.00	0.00	0.00	0.00	0.00		\$216.75	\$16.58	\$0.00	\$0.00	\$0.00	\$0.00	\$16.58	\$200.17
			S	0.00	8.50	8.50	0.00	8.50	0.00	0.00	25.50	8.50	\$216.75							
Luzama, Petrus P.O. Box 20538 Barrigada, Guam 96921	9803 S	Construction Laborer	O	0.00	0.00	0.00	0.00	0.00	0.00	0.00	0.00			\$0.00	\$0.00	\$0.00	\$0.00	\$0.00	\$0.00	\$0.00
			S	0.00	0.00	0.00	0.00	0.00	0.00	0.00	8.50		\$0.00							
Munar, Florante (H2-B) P.O. Box 20538 Barrigada, Guam 96921	6711 S	Carpenter	O	0.00	0.00	0.00	0.00	2.50	0.00	0.00	2.50	\$20.34	\$593.25	\$0.00	\$62.00	\$35.00	\$0.00	\$0.00	\$97.00	\$496.25
			S	8.50	8.50	8.50	2.50	6.00	0.00	0.00	40.00	13.56	\$593.25							
Bansil, Ray P.O. Box 20538 Barrigada, Guam 96921	3135 M	Carpenter	O	0.00	0.00	0.00	0.00	2.50	0.00	0.00	2.50	\$21.00	\$612.50	\$42.73	\$16.00	\$0.00	\$53.97	\$0.00	\$112.70	\$499.80
			S	8.50	8.50	8.50	6.00	0.00	0.00	40.00	14.00	\$612.50								
Pascua, Ernesto B. (H-2B) P.O. Box 20538 Barrigada, Guam	5212 S	Heavy Equipment Operator	O	0.00	0.00	0.00	0.00	0.00	0.00	0.00	0.00		\$117.05	\$0.00	\$40.00	\$35.00	\$0.00	\$0.00	\$75.00	\$372.53
			S	0.00	0.00	0.00	0.00	8.50	0.00	0.00	8.50	13.77	\$447.53							
			O																	
			S																	
			O																	
			S																	

While completion of Form WH-347 is optional, it is mandatory for covered contractors and subcontractors performing work on Federally financed or assisted construction contracts to respond to the information collection contained in 29 C.F.R. §§ 3.3, 5.5(a). The Copeland Act (40 U.S.C. § 3145) contractors and subcontractors performing work on Federally financed or assisted construction contracts to "furnish weekly a statement with respect to the wages paid each employee during the preceding week." U.S. Department of Labor (DOL) regulations at 29 C.F.R. § 5.5(a)(3)(ii) require contractors to submit weekly a copy of all payrolls to the Federal agency contracting for or financing the construction project, accompanied by a signed "Statement of Compliance" indicating that the payrolls are correct and complete and that each laborer or mechanic has been paid not less than the proper Davis-Bacon prevailing wage rate for the work performed. DOL and federal contracting agencies receiving this information review the information to determine that employees have received legally required wages and fringe benefits.

Public Burden Statement

We estimate that it will take an average of 55 minutes to complete this collection, including time for reviewing instructions, searching existing data sources, gathering and maintaining the data needed, and completing and reviewing the collection of information. If you have any comments regarding these estimates or any other aspect of this collection, including suggestions for reducing this burden, send them to the Administrator, Wage and Hour Division, U.S. Department of Labor, Room S3502, 200 Constitution Avenue, N.W. Washington, D.C. 20210



Date 06/18/2015

I, HYON SANG KIM OPERATIONS MANAGER  
(Name of Signatory Party) (Title)

do hereby state:

(1) That I pay or supervise the payment of the persons employed by

KORANDO CORPORATION on the  
(Contractor or Subcontractor)  
380H Harmon Industrial Park, Tammuning, GU ; that during the payroll period commencing on the  
(Building or Work)

13 day of April, 2015, and ending the 19 day of April, 2015,

all persons employed on said project have been paid the full weekly wages earned, that no rebates have been or will be made either directly or indirectly to or on behalf of said

KORANDO CORPORATION from the full  
(Contractor or Subcontractor)

weekly wages earned by any person and that no deductions have been made either directly or indirectly from the full wages earned by any person, other than permissible deductions as defined in Regulations, Part 3 (29 C.F.R. Subtitle A), issued by the Secretary of Labor under the Copeland Act, as amended (48 Stat. 948, 63 Stat. 108, 72 Stat. 967; 76 Stat. 357; 40 U.S.C. § 3145), and described below.

\_\_\_\_\_  
\_\_\_\_\_  
\_\_\_\_\_

(2) That any payrolls otherwise under this contract required to be submitted for the above period are correct and complete; that the wage rates for laborers or mechanics contained therein are not less than the applicable wage rates contained in any wage determination incorporated into the contract; that the classifications set forth therein for each laborer or mechanic conform with the work he performed.

(3) That any apprentices employed in the above period are duly registered in a bona fide apprenticeship program registered with a State apprenticeship agency recognized by the Bureau of Apprenticeship and Training, United States Department of Labor, or if no such recognized agency exists in a State, are registered with the Bureau of Apprenticeship and Training, United States Department of Labor.

(4) That:

(a) WHERE FRINGE BENEFITS ARE PAID TO APPROVED PLANS, FUNDS, OR PROGRAMS

- in addition to the basic hourly wage rates paid to each laborer or mechanic listed in the above referenced payroll, payments of fringe benefits as listed in the contract have been or will be made to appropriate programs for the benefit of such employees, except as noted in section 4(c) below.

(b) WHERE FRINGE BENEFITS ARE PAID IN CASH

- Each laborer or mechanic listed in the above referenced payroll has been paid, as indicated on the payroll, an amount not less than the sum of the applicable basic hourly wage rate plus the amount of the required fringe benefits as listed in the contract, except as noted in section 4(c) below.

(c) EXCEPTIONS

EXCEPTION (CRAFT)	EXPLANATION

REMARKS:

This CPR is a revised for payroll no. 15 according to Contractor Production Report reflects (1) Heavy Equipment Operator at 8.5 hours, Pascua, Ernesto Jr. B. is not reported on the Certified Payroll on April 17, 2015

NAME AND TITLE

Hyon Sang Kim / Operations Manager

SIGNATURE

THE WILLFUL FALSIFICATION OF ANY OF THE ABOVE STATEMENTS MAY SUBJECT THE CONTRACTOR OR SUBCONTRACTOR TO CIVIL OR CRIMINAL PROSECUTION. SEE SECTION 1001 OF TITLE 18 AND SECTION 231 OF TITLE 31 OF THE UNITED STATES CODE.





**KORANDO CORPORATION**  
**GENERAL CONTRACTOR**  
PO BOX 20538 GMF, GUAM 96921  
Tel Nos. (671) 649-7880/81 Fax (671) 649-7882

**COPY**

**BILE / FIGUA BRIDGE REPLACEMENT  
(CONSTRUCTION PHASE)  
PROJECT NO.: GU-NH-NBIS (007)**

**CERTIFIED PAYROLL REPORTS  
FOR WEEK ENDING 03/22 – 06/07/2015**

Payroll Summary & Copy of Check stubs

- Reflecting the difference in wage of \$1.28
- \$9.78 should be the rate used in lieu of \$8.50
  1. Leg, Kerman
  2. Luzuma, Petrus

  
Stanley Consultants Inc.  
  
Signature  
  
Date 

Korando Corporation, P.O. Box 20536, Barrigada, GU 96921

KORANDO CORPORATION

3123

Employee					SSN	Status (Fed/State)	Allowances/Extra
Kerman Leg, P.O. Box 3601, Hagatna, GU 96932					***-**-2346	Married	Fed-1/0
					Pay Period: 03/18/2015 - 06/07/2015		Pay Date: 06/19/2015
Earnings and Hours		Hours	Rate	Current	YTD Amount		
Hourly- Direct labor		386:30	1.28	494.72	4,935.97		
Overtime (x1.5) hourly- Direct		7:30	1.92	14.40	110.04		
		394:00		509.12	5,046.01		
Taxes				Current	YTD Amount		
Medicare Employee Addl Tax				0.00			
Federal Withholding				-27.00	-103.00		
Social Security Employee				-31.56	-312.85		
Medicare Employee				-7.39	-73.17		
				-65.95	-489.02		
Net Pay				443.17	4,556.99		

Korando Corporation, P.O. Box 20536, Barrigada, GU 96921

Handwritten notes and stamps, including a date stamp "JUN 19 2015" and other illegible markings.

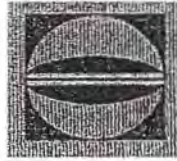

# KORANDO CORPORATION

GENERAL CONTRACTOR

P.O. BOX 20538 BARRIGADA, GUAM 96921

TEL NO'S.: (671) 649-7880/81 FAX: (671) 649-7882

## "PAYROLL SUMMARY"

PROJECT: BILE / PIGUA BRIDGE REPLACEMENT (CONSTRUCTION PHASE)  
PROJECT NO. GU-NH-NBIS (007)

SUBJECT: LEG, KERMAN

(Certified Payroll)

DESCRIPTIONS:

a) Reflecting the difference in wage of \$1.28

b) \$9.78 should be the rate used in lieu of \$8.50

CHECK DATE	FOR: PAY PERIOD ENDING	WAGE Difference	Regular Hours	O/T Hours	TOTAL GROSS	FICA TAX	W/H TAX	TOTAL DEDUCTIONS	TOTAL NET PAY
6/19/2015	03/16 - 06/07/2015	\$ 1.28	362.5	5	\$ 473.60	\$ 38.95	\$ 27.00	\$ 65.95	\$ 443.17
					\$ 509.12				
		TOTAL >	362.5	5	\$ 509.12	\$ 38.95	\$ 27.00	\$ 65.95	\$ 443.17



KORANDO CORPORATION

3124

Employee					SSN	Status (Fed/State)	Allowances/Extra
Petrus Luzama, PMB 429 130 W. Marine Dr., Dededo, GU 96929					***-**-9603	Single	Fed-5/0
					Pay Period: 03/16/2015 - 03/22/2015		Pay Date: 06/19/2015
Earnings and Hours		Hours	Rate	Current	YTD Amount		
Hourly- Direct labor		25:00	1.28	32.00	5,735.50		
Overtime (x1.5) hourly- Direct				0.00	95.63		
		25:00		32.00	5,831.13		
Taxes				Current	YTD Amount		
Medicare Employee Addl Tax				0.00			
Federal Withholding				0.00			
Social Security Employee				-1.98	-361.53		
Medicare Employee				-0.46	-84.55		
				-2.44	-446.08		
Net Pay				29.56	5,385.05		

Korando Corporation, P.O. Box 20538, Barrigada, GU 96921

*[Faint, illegible text, possibly a stamp or signature]*

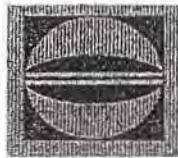

**KORANDO CORPORATION**

GENERAL CONTRACTOR

P.O. BOX 20538 BARRIGADA, GUAM 96921

TEL NO'S.: (671) 649-7880/81 FAX: (671) 649-7882

**"PAYROLL SUMMARY"**

PROJECT: BILE / PIGUA BRIDGE REPLACEMENT (CONSTRUCTION PHASE)  
PROJECT NO. GU-NH-NBIS (007)

SUBJECT: LUZUMA, PETRUS (Certified Payroll)

DESCRIPTIONS: a) Reflecting the difference in wage of \$1.28  
b) \$9.78 should be the rate used in lieu of \$8.50

CHECK DATE	FOR: PAY PERIOD ENDING	WAGE Difference	Regular Hours	O/T Hours	TOTAL GROSS	FICA TAX	W/H TAX	TOTAL DEDUCTIONS	TOTAL NET PAY
6/19/2015	03/16 - 22/2015	\$ 1.28	16	0	\$ 20.48 \$ 32.00	\$ 2.44	\$	\$ 2.44	\$ 29.56
TOTAL >			16	0	\$ 32.00	\$ 2.44	\$	\$ 2.44	\$ 29.56



**KORANDO CORPORATION**

**GENERAL CONTRACTOR**

PO BOX 20538 GMF, GUAM 96921

Tel Nos. (671) 649-7880/81 Fax (671) 649-7882

**FILE COPY**

**BILE / PIGUA BRIDGE REPLACEMENT  
(CONSTRUCTION PHASE)  
PROJECT NO.: GU-NH-NBIS (007)**

**CERTIFIED PAYROLL REPORTS  
FOR WEEK ENDING 06-21-2015**

  
Stanley Consultants Inc.  
  
Signature  
7/1/15 @ 12:50 pm  
Date



U.S. Department of Labor  
Wage and Hour Division

PAYROLL

(For Contractor's Optional Use; See Instructions at [www.dol.gov/whd/forms/wh347instr.htm](http://www.dol.gov/whd/forms/wh347instr.htm))



U.S. Wage and Hour Division  
Rev. Dec. 2008

Persons are not required to respond to the collection of information unless it displays a currently valid OMB control number.

NAME OF CONTRACTOR <input checked="" type="checkbox"/> OR SUBCONTRACTOR <input type="checkbox"/>		ADDRESS		OMB No.: 1235-0008	
KORANDO CORPORATION		P.O. BOX 20538 BARRIGADA, GUAM 96921		Expires: 01/31/2015	
PAYROLL NO. 24	FOR WEEK ENDING 06/21/2015	PROJECT AND LOCATION Bile/Pigua Bridge Replacement (Construction Phase) Along Route 4, Merizo, Guam		PROJECT OR CONTRACT NO. GU-NH-NBIS (007)	

(1) NAME AND INDIVIDUAL IDENTIFYING NUMBER (e.g., LAST FOUR DIGITS OF SOCIAL SECURITY NUMBER) OF WORKER	(2) NO. OF WITHHOLDING EXEMPTIONS	(3) WORK CLASSIFICATION	OT. CRST.	(4) DAY AND DATE							(5) TOTAL HOURS	(6) RATE OF PAY	(7) GROSS AMOUNT EARNED	(8) DEDUCTIONS					(9) NET WAGES PAID FOR WEEK	
				M	T	W	TH	F	SA	SU				FICA	WITH-HOLDING TAX	B/L	Aflac Medical	OTHER		TOTAL DEDUCTIONS
				15	16	17	18	19	20	21										
Javelosa, Lauro E. P.O. Box 20538 Barrigada, Guam 96921	5139 S	Construction Laborer	O	0.00	0.00	0.00	0.00	0.00	0.00	0.00		\$19.31	\$0.00	\$0.00	\$0.00	\$0.00	\$0.00			
			S	0.00	0.00	0.00	0.00	0.00	0.00	0.00		12.87							\$0.00	
Leg, Kerman P.O. Box 20538 Barrigada, Guam 96921	2346 M	Construction Laborer	O	0.00	0.00	0.00	0.00	0.00	0.00	0.00		\$12.75	\$332.52	\$25.44	\$9.00	\$0.00	\$0.00	\$0.00	\$34.44	\$298.08
			S	8.50	8.50	0.00	8.50	8.50	0.00	0.00	34.00	9.78								
Wada, Matthew P.O. Box 20538 Barrigada, Guam 96921	3262 S	Apprenticeship (Cement Mason)	O	0.00	0.00	0.00	0.00	2.50	0.00	0.00	2.50	\$14.48	\$422.20	\$34.51	\$41.00	\$0.00	\$0.00	\$0.00	\$75.51	\$375.65
			S	8.50	8.50	8.50	8.50	0.00	0.00	40.00	9.65	\$451.16								
Munar, Florante (H2-B) P.O. Box 20538 Barrigada, Guam 96921	6711 S	Carpenter	O	0.00	0.00	0.00	0.00	0.00	0.00	0.00		\$20.34	\$461.04	\$0.00	\$42.00	\$35.00	\$0.00	\$0.00	\$77.00	\$384.04
			S	8.50	8.50	8.50	8.50	0.00	0.00	34.00	13.56	\$461.04								
Bansil, Ray P.O. Box 20538 Barrigada, Guam 96921	3135 M	Carpenter	O	0.00	0.00	0.00	0.00	2.50	0.00	0.00	2.50	\$21.00	\$612.50	\$42.73	\$16.00	\$0.00	\$53.97	\$0.00	\$112.70	\$499.80
			S	8.50	8.50	8.50	8.50	0.00	0.00	40.00	14.06	\$612.50								
Pascua, Ernesto B. (H2-B) P.O. Box 20538 Barrigada, Guam 96921	5212 S	Heavy Equipment Operator	O	0.00	0.00	0.00	0.00	2.00	0.00	0.00	2.00	\$20.66	\$592.12	\$0.00	\$62.00	\$35.00	\$0.00	\$0.00	\$97.00	\$495.00
			S	8.50	8.50	8.50	8.50	0.00	0.00	40.00	13.77	\$592.12								
Bansil, Raul (H2-B) P.O. Box 20538 Barrigada, Guam 96921	8167 S	Cement Mason	O	0.00	0.00	0.00	0.00	2.50	0.00	0.00	2.50	\$19.31	\$563.08	\$0.00	\$57.00	\$35.00	\$0.00	\$0.00	\$92.00	\$471.08
			S	8.50	8.50	8.50	8.50	0.00	0.00	40.00	12.87	\$563.08								
Ichin, A.S. P.O. Box 20538 Barrigada, Guam 96921	8409 S	Apprenticeship (Cement Mason)	O	0.00	0.00	0.00	0.00	0.00	0.00	0.00		\$14.48	\$328.10	\$26.57	\$25.00	\$0.00	\$0.00	\$0.00	\$51.57	\$295.83
			S	8.50	8.50	0.00	8.50	8.50	0.00	0.00	34.00	9.65								

While completion of Form WH-347 is optional, it is mandatory for covered contractors and subcontractors performing work on Federally financed or assisted construction contracts to respond to the information collection contained in 29 C.F.R. §§ 3.3, 5.5(a). The Copeland Act (40 U.S.C. § 3145) contractors and subcontractors performing work on Federally financed or assisted construction contracts to "furnish weekly a statement with respect to the wages paid each employee during the preceding week." U.S. Department of Labor (DOL) regulations at 29 C.F.R. § 5.5(e)(3)(ii) require contractors to submit weekly a copy of all payrolls to the Federal agency contracting for or financing the construction project, accompanied by a signed "Statement of Compliance" indicating that the payrolls are correct and complete and that each laborer or mechanic has been paid not less than the proper Davis-Bacon prevailing wage rate for the work performed. DOL and federal contracting agencies receiving this information review the information to determine that employees have received legally required wages and fringe benefits.

Public Burden Statement

We estimate that it will take an average of 55 minutes to complete this collection, including time for reviewing instructions, searching existing data sources, gathering and maintaining the data needed, and completing and reviewing the collection of information. If you have any comments regarding these estimates or any other aspect of this collection, including suggestions for reducing this burden, send them to the Administrator, Wage and Hour Division, U.S. Department of Labor, Room 53502, 200 Constitution Avenue, N.W., Washington, D.C. 20210

Date 06/24/2015

I, HYON SANG KIM OPERATIONS MANAGER  
(Name of Signatory Party) (Title)

do hereby state:

(1) That I pay or supervise the payment of the persons employed by

KORANDO CORPORATION on the  
(Contractor or Subcontractor)  
380H Harmon Industrial Park, Tamuning, GU, that during the payroll period commencing on the  
(Building or Work)  
15 day of June, 2015, and ending the 21 day of June, 2015,

all persons employed on said project have been paid the full weekly wages earned, that no rebates have been or will be made either directly or indirectly to or on behalf of said

KORANDO CORPORATION from the full  
(Contractor or Subcontractor)

weekly wages earned by any person and that no deductions have been made either directly or indirectly from the full wages earned by any person, other than permissible deductions as defined in Regulations, Part 3 (29 C.F.R. Subtitle A), issued by the Secretary of Labor under the Copeland Act, as amended (48 Stat. 948, 63 Stat. 108, 72 Stat. 967, 76 Stat. 357; 40 U.S.C. § 3145), and described below:

\_\_\_\_\_  
\_\_\_\_\_  
\_\_\_\_\_

(2) That any payrolls otherwise under this contract required to be submitted for the above period are correct and complete; that the wage rates for laborers or mechanics contained therein are not less than the applicable wage rates contained in any wage determination incorporated into the contract; that the classifications set forth therein for each laborer or mechanic conform with the work he performed.

(3) That any apprentices employed in the above period are duly registered in a bona fide apprenticeship program registered with a State apprenticeship agency recognized by the Bureau of Apprenticeship and Training, United States Department of Labor, or if no such recognized agency exists in a State, are registered with the Bureau of Apprenticeship and Training, United States Department of Labor.

(4) That:

(a) WHERE FRINGE BENEFITS ARE PAID TO APPROVED PLANS, FUNDS, OR PROGRAMS

- in addition to the basic hourly wage rates paid to each laborer or mechanic listed in the above referenced payroll, payments of fringe benefits as listed in the contract have been or will be made to appropriate programs for the benefit of such employees, except as noted in section 4(c) below.

(b) WHERE FRINGE BENEFITS ARE PAID IN CASH

- Each laborer or mechanic listed in the above referenced payroll has been paid, as indicated on the payroll, an amount not less than the sum of the applicable basic hourly wage rate plus the amount of the required fringe benefits as listed in the contract, except as noted in section 4(c) below.

(c) EXCEPTIONS

EXCEPTION (CRAFT)	EXPLANATION

REMARKS

NAME AND TITLE: Hyon Sang Kim / Operations Manager SIGNATURE: [Signature]

THE WILLFUL FALSIFICATION OF ANY OF THE ABOVE STATEMENTS MAY SUBJECT THE CONTRACTOR OR SUBCONTRACTOR TO CIVIL OR CRIMINAL PROSECUTION. SEE SECTION 1001 OF TITLE 18 AND SECTION 231 OF TITLE 31 OF THE UNITED STATES CODE.



**KORANDO CORPORATION**

**GENERAL CONTRACTOR**



PO BOX 20538 GMF, GUAM 96921

Tel Nos. (671) 649-7880/81 Fax (671) 649-7882

**COPY**

**BILE / PIGUA BRIDGE REPLACEMENT  
(CONSTRUCTION PHASE)  
PROJECT NO.: GU-NH-NBIS (007)**

**CERTIFIED PAYROLL REPORTS  
FOR WEEK ENDING 06-28-2015**

	
Stanley Consultants Inc.	
 _____ Signature	<i>7/1/15 12:00pm</i> _____ Date



U.S. Department of Labor  
Wage and Hour Division

PAYROLL

(For Contractor's Optional Use; See Instructions at [www.dol.gov/whd/forms/wh347instr.htm](http://www.dol.gov/whd/forms/wh347instr.htm))



Persons are not required to respond to the collection of information unless it displays a currently valid OMB control number.

NAME OF CONTRACTOR  OR SUBCONTRACTOR   
 KORANDO CORPORATION  
 ADDRESS P.O. BOX 20538  
 BARRIGADA, GUAM 96921  
 OMB No.: 1235-0008  
 Expires: 01/31/2015

PAYROLL NO. 25 FOR WEEK ENDING 06/28/2015  
 PROJECT AND LOCATION Bile/Pigua Bridge Replacement (Construction Phase)  
 Along Route 4, Merizo, Guam  
 PROJECT OR CONTRACT NO. GU-NH-NBIS (007)

(1) NAME AND INDIVIDUAL IDENTIFYING NUMBER (e.g., LAST FOUR DIGITS OF SOCIAL SECURITY NUMBER) OF WORKER	(2) NO. OF WITHHOLDING EXEMPTIONS	(3) WORK CLASSIFICATION	(4) DAY AND DATE							(5) OT OR ET	(6) TOTAL HOURS	(7) RATE OF PAY	(7) GROSS AMOUNT EARNED	(8) DEDUCTIONS					(9) NET WAGES PAID FOR WEEK	
			M	T	W	TH	F	SA	SU					FICA	WITH- HOLDING TAX	D/L	Affac Medical	OTHER		TOTAL DEDUCTIONS
			22	23	24	25	26	27	28					HOURS WORKED EACH DAY						
Javelosa, Lauro E. P.O. Box 20538 Barrigada, Guam 96921	5139 S	1 Construction Laborer	O	0.00	0.00	0.00	0.00	0.00	0.00	0.00		\$19.31	\$0.00	\$0.00	\$0.00	\$0.00	\$0.00			
			S	0.50	0.00	0.00	0.00	0.00	0.00	0.00		12.87							\$0.00	
Leg, Kerman P.O. Box 20538 Barrigada, Guam 96921	2346 M	1 Construction Laborer	O	0.00	0.00	0.00	0.00	0.00	0.00	0.00		\$12.75	\$332.52	\$25.43	\$9.00	\$0.00	\$0.00	\$0.00	\$34.43	\$298.09
			S	8.50	8.50	0.00	8.50	8.50	0.00	0.00		34.00								
Wada, Matthew P.O. Box 20538 Barrigada, Guam 96921	3262 S	1 Apprenticeship (Cement Mason)	O	0.00	0.00	0.00	0.00	2.50	0.00	0.00	2.50	\$14.48	\$422.20	\$34.51	\$41.00	\$0.00	\$0.00	\$0.00	\$75.51	\$375.65
			S	8.50	8.50	8.50	8.50	0.00	0.00	0.00		40.00								
Munar, Florante (H2-B) P.O. Box 20538 Barrigada, Guam 96921	6711 S	1 Carpenter	O	0.00	0.00	0.00	0.00	1.50	0.00	0.00	2.50	\$20.34	\$593.25	\$0.00	\$62.00	\$35.00	\$0.00	\$0.00	\$97.00	\$496.25
			S	1.50	8.50	8.50	8.50	0.00	0.00	0.00		40.00								
Bansil, Ray P.O. Box 20538 Barrigada, Guam 96921	3135 M	3 Carpenter	O	0.00	0.00	0.00	0.00	1.50	0.00	0.00	2.50	\$21.00	\$612.50	\$42.73	\$16.00	\$0.00	\$53.97	\$0.00	\$112.70	\$499.80
			S	8.50	8.50	8.50	8.50	0.00	0.00	0.00		40.00								
Pascua, Ernesto B. (H2-B) P.O. Box 20538 Barrigada, Guam 96921	5212 S	1 Heavy Equipment Operator	O	0.00	0.00	0.00	0.00	2.50	0.00	0.00	2.50	\$20.66	\$602.45	\$0.00	\$63.00	\$35.00	\$0.00	\$0.00	\$98.00	\$504.45
			S	8.50	8.50	8.50	8.50	0.00	0.00	0.00		40.00								
Bansil, Raul (H2-B) P.O. Box 20538 Barrigada, Guam 96921	8167 S	1 Cement Mason	O	0.00	0.00	0.00	0.00	2.50	0.00	0.00	2.50	\$19.31	\$563.08	\$0.00	\$57.00	\$35.00	\$0.00	\$0.00	\$92.00	\$471.08
			S	8.50	8.50	8.50	8.50	0.00	0.00	0.00		40.00								
Ichin, A.S. P.O. Box 20538 Barrigada, Guam 96921	8409 S	1 Apprenticeship (Cement Mason)	O	0.00	0.00	0.00	0.00	2.50	0.00	0.00	2.50	\$14.48	\$422.20	\$32.31	\$36.00	\$0.00	\$0.00	\$0.00	\$68.31	\$353.89
			S	1.50	8.50	8.50	8.50	0.00	0.00	0.00		40.00								

While completion of Form WH-347 is optional, it is mandatory for covered contractors and subcontractors performing work on Federally financed or assisted construction contracts to respond to the information collection contained in 29 C.F.R. §§ 3.3, 5.5(a). The Copeland Act (40 U.S.C. § 3145) contractors and subcontractors performing work on Federally financed or assisted construction contracts to "furnish weekly a statement with respect to the wages paid each employee during the preceding week." U.S. Department of Labor (DOL) regulations at 29 C.F.R. § 5.5(a)(3)(ii) require contractors to submit weekly a copy of all payrolls to the Federal agency contracting for or financing the construction project, accompanied by a signed "Statement of Compliance" indicating that the payrolls are correct and complete and that each laborer or mechanic has been paid not less than the proper Davis-Bacon prevailing wage rate for the work performed. DOL and federal contracting agencies receiving this information review the information to determine that employees have received legally required wages and fringe benefits.

Public Burden Statement

We estimate that it will take an average of 55 minutes to complete this collection, including time for reviewing instructions, searching existing data sources, gathering and maintaining the data needed, and completing and reviewing the collection of information. If you have any comments regarding these estimates or any other aspect of this collection, including suggestions for reducing this burden, send them to the Administrator, Wage and Hour Division, U.S. Department of Labor, Room S3502, 200 Constitution Avenue, N.W., Washington, D.C. 20210

Date 07/01/2015

I, HYON SANG KIM OPERATIONS MANAGER  
(Name of Signatory Party) (Title)

do hereby state:

(1) That I pay or supervise the payment of the persons employed by

KORANDO CORPORATION on the  
(Contractor or Subcontractor)

380H Harmon Industrial Park, Tamuning, GU, that during the payroll period commencing on the  
(Building or Work)  
22 day of June, 2015, and ending the 28 day of June, 2015

all persons employed on said project have been paid the full weekly wages earned, that no rebates have been or will be made either directly or indirectly to or on behalf of said

KORANDO CORPORATION from the full  
(Contractor or Subcontractor)

weekly wages earned by any person and that no deductions have been made either directly or indirectly from the full wages earned by any person, other than permissible deductions as defined in Regulations, Part 3 (29 C.F.R. Subtitle A), issued by the Secretary of Labor under the Copeland Act, as amended (48 Stat. 948, 63 Stat. 108, 72 Stat. 967; 76 Stat. 357; 40 U.S.C. § 3145), and described below:

\_\_\_\_\_  
\_\_\_\_\_  
\_\_\_\_\_

(2) That any payrolls otherwise under this contract required to be submitted for the above period are correct and complete; that the wage rates for laborers or mechanics contained therein are not less than the applicable wage rates contained in any wage determination incorporated into the contract; that the classifications set forth therein for each laborer or mechanic conform with the work he performed.

(3) That any apprentices employed in the above period are duly registered in a bona fide apprenticeship program registered with a State apprenticeship agency recognized by the Bureau of Apprenticeship and Training, United States Department of Labor, or if no such recognized agency exists in a State, are registered with the Bureau of Apprenticeship and Training, United States Department of Labor.

(4) That:

(a) WHERE FRINGE BENEFITS ARE PAID TO APPROVED PLANS, FUNDS, OR PROGRAMS

-- in addition to the basic hourly wage rates paid to each laborer or mechanic listed in the above referenced payroll, payments of fringe benefits as listed in the contract have been or will be made to appropriate programs for the benefit of such employees, except as noted in section 4(c) below.

(b) WHERE FRINGE BENEFITS ARE PAID IN CASH

-- Each laborer or mechanic listed in the above referenced payroll has been paid, as indicated on the payroll, an amount not less than the sum of the applicable basic hourly wage rate plus the amount of the required fringe benefits as listed in the contract, except as noted in section 4(c) below.

(c) EXCEPTIONS

EXCEPTION (CRAFT)	EXPLANATION

REMARKS:

NAME AND TITLE  
Hyon Sang Kim / Operations Manager

SIGNATURE  

THE WILLFUL FALSIFICATION OF ANY OF THE ABOVE STATEMENTS MAY SUBJECT THE CONTRACTOR OR SUBCONTRACTOR TO CIVIL OR CRIMINAL PROSECUTION. SEE SECTION 1001 OF TITLE 18 AND SECTION 231 OF TITLE 31 OF THE UNITED STATES CODE.

**ATTACHMENT C**





**KORANDO CORPORATION**  
**GENERAL CONTRACTOR**

P.O. BOX 20538  
 GMF, GUAM 96921  
 TEL: (671) 649-7880  
 (671) 649-7881  
 FAX: (671) 649-7882  
 EMAIL: admin\_korando@teleguam.net

Project : Bile/Pigua Bridge Replacement  
 Project No. GU-NH-NBIS(007)

Subject : NOTICE OF DEFAULT - Response

4. Section 155.06 – Schedule Updates.

The recovery schedule shows that the project are having a delays of 59 days. Notice here that the primary overhead electrical works is the one driving the pile driving works in which also is the predecessor of all major works. Korando's pile driving subcontractor which is Smithbridge has commented that pile driving was impossible unless overhead electrical primary line is relocated. Once pile is driven, this recovery works are compose of two (2) groups in which work will be done dayshift & nightshift. The water relocation is not critical activities because the installation works can be done at any time within project period. The temporary steel bridge has minor design revisions but once done and approved will right away deliver and site fabricate/install at its location (critical).

12. Instruction 1.3 to bidders Article 25 Termination of Work on Failure to Pay Agreed Wages.

H-2B requirement has been complied. The list of H-2B has been submitted and the worker's work limitation has been corrected. Korando Corporation is following USDOL labor and Davis Bacon standards.

*Ten (10) calendar days from receipt of this Notice of Default*

(a) Commence meaningful work on the project:

Korando has schedule preparatory meeting on the demolition methodology of the half of the bridge on Monday, July 6, 2015. Demolition work shall follow afterwards and this will be done in a safely manner. Fabrication of precast pile has been done already. Fabrication of box beam will also be starts after casting bed reach to its required strength. Electrical relocations submittal comments from GPA has been already address and will be submitted next week for GPA review and approval, once stamp and will submit to Stanley Consultant with their further approval.

(b) Supply enough properly skilled workmen and provide the materials to complete the work within the contract term:

Korando and BBR will mobilize and deliver the materials which was stock at Korando's Harmon warehouse to Merizo staging area within this week and next week.

(c) To submit acceptable updated Project schedule:

A realistic progress schedule as of June 30, 2015 is attached. Total Float is -59 Days

(d) The other listed defects

**ATTACHMENT D**



*The Honorable*  
**Eddie Baza Calvo**  
*Governor*

*The Honorable*  
**Ray Tenorio**  
*Lieutenant Governor*

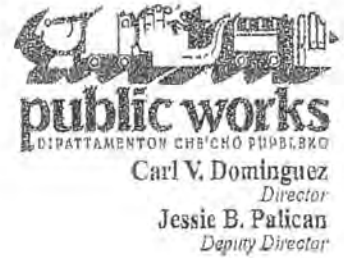

December 29, 2014

Mr. Byong Ho Kim  
President  
Korando Corporation  
380H Harmon Industrial Park  
Tamuning, Guam 96913

**Re: Bile / Pigua Bridges Replacement**  
**Project No. GU-NH-NBIS(007)**  
**NOTICE TO PROCEED**

Dear Mr. Kim,

You are hereby notified to commence work on the above referenced project on **Monday, January 5, 2015** which shall be day number one (1) of the working days stipulated in the Contract. All work, including final cleanup shall be completed within **450** calendar days. Failure to complete the entire project within the **500** calendar days stipulated in the contract will result in Liquidated Damages being assessed in the amount of **\$2,200.00** per calendar day.

All changes, deviations from, or clarifications to the plans and specifications will be valid only if directed, in writing, by the Department of Public Works Contracting Officer. All inspections, acceptance testing and other requirements shall be coordinated with the Department of Public Works.

**Please include the above Project Name and Project Number on all project correspondence.**

Should you have any questions or need additional information, please contact Mr. Jack Marlow, Chief Resident Project Representative with Stanley Consultants at 646-3466, Mr. Crispin Bensen, Project Engineer, DPW or Mr. Mike Lanning, Guam Program Manager with Parsons Transportation Group at 648-1060.

Acknowledge receipt of this notice on the space provided below and return a copy to the Department of Public Works, Division of Highways to the attention of Mr. Isidro Duarosan, Engineer Supervisor.



Sincerely,



CARL V. DOMINGUEZ



IDuarosan/PSMagel /JBlaZ

Cc: Jack Marlow, Stanley  
Crispin Bensen, DPW  
Mike Lanning, PTG  
Richelle Takara, FHWA

RECEIPT OF THE ABOVE NOTICE TO PROCEED IS HEREBY ACKNOWLEDGED

THIS 2nd DAY OF JANUARY 2014. 5

By: BYONG HO KIM - PRESIDENT  
(Print Name & Title)

Signature: 

2

14-0324  
Bile / Pigua Bridge Replacements  
Project No. GU-NH-NBIS(007)

CONTRACT NO.

CONTRACT

KORANDO CORPORATION  
( CONTRACTOR )

And

GOVERNMENT OF GUAM

Contract for: BILE / PIGUA BRIDGE REPLACEMENT  
Project No.: GU-NH-NBIS(007)  
Amount: \$ 3,665,559.00  
LOCATION: Merizo, GUAM

RECEIVED  
MAY 07 2014  
Bureau of Budget and  
Management Research

FC-1

050614-2142

RECEIVED

Bile / Pigua Bridge Replacements  
Project No. GU-NH-NBIS(007)

MAY 07 2014

Bureau of Budget and  
Management Research

FORMAL CONTRACT

THIS AGREEMENT AND FORMAL CONTRACT, made and entered into this \_\_\_\_\_ day of, \_\_\_\_\_ 2014, by and between the Government of Guam, hereinafter called the "Government," represented by the Contracting Officer executing this contract, party of the first part, and, a corporation of Guam, KORANDO CORPORATION hereinafter called the "Contractor," party of the second part.

WITNESSETH, That whereas the Government requires the contractor to construct, Bile / Pigua Bridge Replacement, Project No. GU-NH-NBIS(007) hereinafter called the "Project," according to the statements of work and contract requirements including special contract requirements and schedule of work prepared by the Department of Public Works,

NOW THEREFORE, the Government and Contractor for the considerations hereinafter set forth, agree as follows:

- I. THE CONTRACTOR AGREES to furnish all the necessary labor, materials, equipment, tools and services necessary to perform and complete in a workmanlike manner all the work required for the construction of the Project, in strict compliance with the contract documents herein mentioned, which are hereby made a part of the contract, including the following addenda:

Addendum No.	Dated
1	December 18, 2013
2	January 09, 2014
3	January 22, 2014
4	February 05, 2014
5	February 11, 2014

(a) Contract Time: The Contractor agrees to commence work under this contract upon written notice to proceed, and to complete the project ready for use and operation within 450 calendar days of the commencement of the contract time as stated in the Notice to Bidders of the contract.



(b) Subcontractors: The Contractor agrees to bind every subcontractor by the terms of the contract documents. The contract documents shall not be construed as creating any contractual relation between any sub-contractor and the Government.

II. THE GOVERNMENT AGREES to pay, and the Contractor agrees to accept, in full payment for the performance of this contract, the contract amount of Three Million Six Hundred Sixty Five Thousand Five Hundred Fifty Nine Dollars (\$ 3,665,559.00), and any sums to be added and/or deducted resulting from all extra and/or omitted work in connection therewith, as authorized under the terms as stated in the Standard Specifications and Special Contract Requirements of the contract, all according to the terms as stated in the contract documents a) Progress payments will be made according to the Special Contract Requirements of the contract.

III. CONTRACT DOCUMENTS: It is hereby mutually agreed that the following list of instruments, plans, specifications and documents which are attached, bound herewith or incorporated herein by reference shall constitute the contract documents, all of which are made a part hereof, and collectively evidence and constitute the contract between the parties hereto, and they are as fully a part of this Agreement as if they were set out verbatim and in full, and are designated as follows:

- a) Invitation and Notice to Bidders
- b) Special Contract Requirements
- c) Proposal and Bid Documents
- d) Contract Documents
- e) Project Location and Drawings
- f) Standard Specifications for Construction of Roads and Bridges on Federal Highway Projects, FP-03
- g) Addendum(s)

IV. LIQUIDATED DAMAGES: The Contractor further agrees to pay to the Government reasonable liquidated damages as stipulated in FP-03 for breach of this contract by the Contractor by his failing, neglecting or refusing to complete the work within the time herein specified and shall be paid for each consecutive calendar day therefore that the Contractor shall be in default after the time stipulated in the contract for completing the work ready for use and/or operation.

V. COVENANT AGAINST CONTINGENT FEES. The Contractor warrants that he has not employed any person to solicit or secure this contract upon any agreement for a commission, percentage, brokerage or contingent fee. Breach of this warranty shall give the Government the right to terminate the contract, or in its discretion, to deduct from the contract price or consideration the amount of commission, percentage, brokerage or contingent fee. The warranty shall not apply to commissions payable by contractors upon contracts or sales secured or made through bonafide established commercial or selling agencies maintained by the Contractor for securing business.

VI. OTHER CONTRACTS. The Government may award other contracts for additional work, and the Contractor shall fully cooperate with such other contractors and carefully fit his own work to that provided under other contracts as may be directed by the Contracting Officer. The Contractor shall not commit or permit any act that will interfere with the performance of work by any other contractor.

VII. DISPUTES. Except as otherwise specifically provided in this contract, all disputes concerning questions of fact arising under this contract shall be decided by the Contracting Officer whose decision shall be final and conclusive upon the parties thereto. Meanwhile the Contractor shall diligently proceed with the work as directed.

VIII. CONTRACT BINDING. It is agreed that this contract and all of the Covenants hereof shall insure to the benefit of and be binding upon the Government and the Contractor respectively and his partners, successors, assignees and legal representatives. Neither the Government nor the Contractor shall have the right to assign, transfer or sublet his interests or obligations hereunder without written consent of the other party. It is hereby mutually agreed by and between the parties hereto that no mechanic, contractor, subcontractor, material man or other person can or contract for or in any other manner have or acquire any lien upon the binding or works covered by this contract, or the land upon which the same is situated.

IX. COMPLIANCE TO PUBLIC LAW 28-98: Restriction Against Contractors Employing Convicted Sex Offenders from Working at Government of Guam Venues.

The final contract between DPW and the awardee shall include the following provisions:

- (1) warranties that no person providing services on behalf of the contractor has been convicted of a sex offense under the provisions of Chapter 25 of Title 9 GCA or an offense as defined in Article

2 of Chapter 28, Title 9 GCA, or an offense in another jurisdiction with, at a minimum, the same elements as such offenses, or who is listed on the Sex Offender Registry; and

- (2) that if any person providing services on behalf of the contractor is convicted of a sex offense under the provisions of Chapter 25 of Title 9 GCA or an offense as defined in Article 2 of Chapter 28, Title 9 GCA, or an offense in another jurisdiction with, at a minimum, the same elements as such offenses, or who is listed on the Sex Offender Registry, that such person will be immediately removed from working at said agency and that the administrator of said agency be informed of such within twenty four (24) hours of such conviction.

**X. COMPLIANCE TO PUBLIC 24-100, PRODUCTS MANUFACTURED FROM RECYCLED GLASS:**

Pursuant to 5 GCA section 5218, any individual or company submitting a response to this solicitation shall include the purchase of available recycled glass pulverized on Guam or appropriate products manufactured therefrom. The contract awarded under this solicitation shall determine the suitable percentage of recycled glass to be used in the project and, as a condition of the award of the contract, shall require the contractor to identify and certify in writing the percentage of recycled glass contained in the material offered. The acceptable percentage of recycled glass has been determined to be 0% for this project.



IN WITNESS WHEREOF the parties hereto have executed this contract as of the day and year first written.

  
\_\_\_\_\_  
CARL V. DOMINGUEZ  
Director  
Department of Public Works  
Contracting Officer

  
\_\_\_\_\_  
HYON SANG KIM  
(Witness)

PO BOX 20538 GMF, GUAM 96921  
(Address)

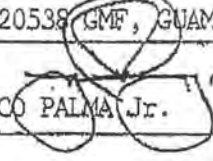
  
\_\_\_\_\_  
FRANCISCO PALMA, Jr.  
(Witness)

PO BOX 20538 GMF, GUAM 96921  
(Address)

BYONG HO KIM -PRESIDENT )  
\_\_\_\_\_) Contractor  
KORANDO CORPORATION )

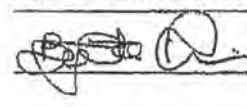
  
\_\_\_\_\_  
380H HARMON INDUSTRIAL PARK  
(Business Address)  
TAMUNING, GUAM 96913

I, HYON SANG KIM certify that I am the secretary of the corporation named as Contractor herein; that BYONG HO KIM who signed this contract on behalf of the Contractor, was then PRESIDENT of said corporation; that said contract was duly signed for and in behalf of said corporation by authority of its governing body, and is within the scope of its corporate powers.

  
\_\_\_\_\_  
(CORPORATE SEAL)

CERTIFIED FUNDS AVAILABLE:

Account No. 5101F141068EB105-230  
\$ 3,665,559.00

04.18.14  
*[Signature]*

**JOAQUIN R. BLAZ, BMA IV**  
Certifying Officer  
Acting Program Administrator  
Highways (Horizontal) Engineering & Maintenance  
Department of Public Works

DATE: 5/2/14

CONCUR:

*[Signature]*  
**CARL V. DOMINGUEZ**  
Director  
Department of Public Works

*[Signature]*  
**EUGENE A. NIEMASZ, P.E.**  
Acting Chief Engineer - Highways  
Department of Public Works  
(Governor's Temporary Appointment)

DATE: 5/2/14

DATE: \_\_\_\_\_

CLEARED AS PER BBMR'S REVIEW

APPROVED AS TO FORM AND LEGALITY:

*[Signature]*  
**JOHN A. RIOS**  
Director  
Bureau of Budget and Management Research

*[Signature]*  
**LEONARDO M. RAPADAS**  
Guam Attorney General

DATE: MAY 19 2014

DATE: 6/2/14  
DPW 14-0324



APPROVED:

*[Signature]*  
**HONORABLE EDDIE BAZA CALVO**  
Governor of Guam

DEPARTMENT OF ADMINISTRATION  
DIVISION OF ACCOUNTS  
Registration Date 06/10/2014  
Registered No. 01406A1230  
Book No. K346007  
Registered By R 06/16/2014

JUN 10 2014

DATE  
FC-7

RECEIVED  
MAY 07 2014  
Bureau of Budget and Management Research

14-0324  
Btle / Pigua Bridge Replacements  
Project No. GU-NH-NBIS(007)

CERTIFIED FUNDS AVAILABLE:

Account No. 5101F141068IB105-230  
\$ 3,665,559.00

04.18.14  
*[Signature]*

**JOAQUIN R. BLAZ, BMA IV**  
Certifying Officer  
Acting Program Administrator  
Highways (Horizontal) Engineering & Maintenance  
Department of Public Works

DATE: 5/2/14

CONCUR:

*[Signature]*  
**CARL V. DOMINGUEZ**  
Director  
Department of Public Works

*[Signature]*  
**EUGENE A. NIEMASZ, P.E.**  
Acting Chief Engineer - Highways  
Department of Public Works  
(Governor's Temporary Appointment)

DATE: 5/2/14

DATE: \_\_\_\_\_

CLEARED AS PER BBMR'S REVIEW

APPROVED AS TO FORM AND LEGALITY:

*[Signature]* **CLEARED PER  
BBMR'S REVIEW**  
**JOHN A. RIOS**  
Director  
Bureau of Budget and Management  
Research

*[Signature]*  
**LEONARDO M. RAPADAS**  
Guam Attorney General

DATE: MAY 19 2014

DATE: 6/2/14  
DPW 14-0324



APPROVED:

*[Signature]*  
**HONORABLE EDDIE BAZA CALVO**  
Governor of Guam

JUN 10 2014

DATE

FC-7

**RECEIVED**

**MAY 07 2014**  
**Bureau of Budget and  
Management Research**

TRANS...



# ATTACHMENT E

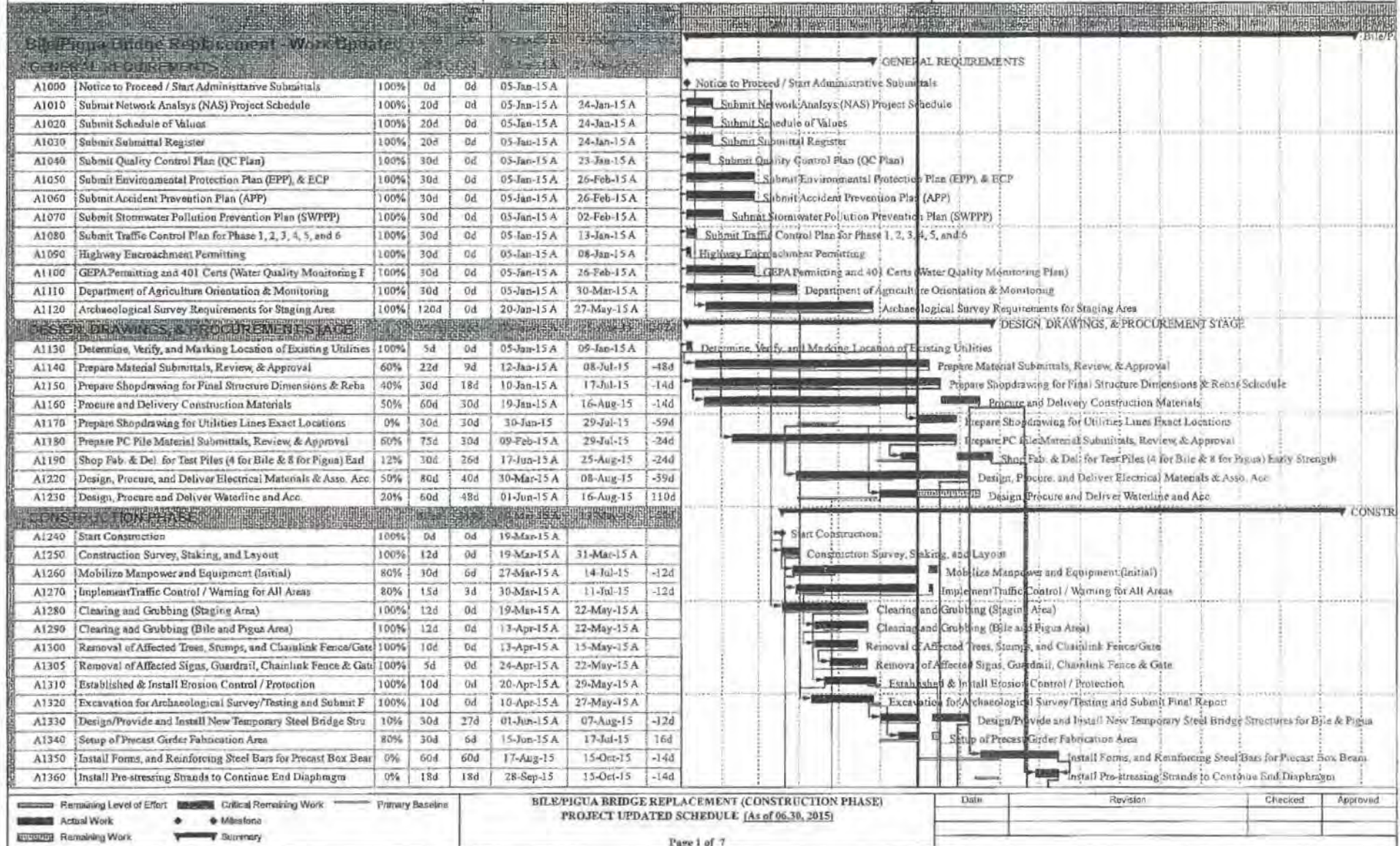

BILE/PIGUA BRIDGE REPLACEMENT (CONSTRUCTION PHASE)  
 PROJECT UPDATED SCHEDULE (As of 06.30.2015)

■	Remaining Level of Effort	■	Critical Remaining Work	—	Primary Baseline
■	Actual Work	◆	Milestone	—	
■	Remaining Work	■	Summary	—	

Date	Revision	Checked	Approved



Project Name: Bile / Pigua Bridge Replacement (Construction Phase)  
 Contract No.: GU-NH-NBIS(007)

Date Date: 30-Jun-15

Run Date: 30-Jun-15

Activity ID	Description	%	Start	End	Start	End	Duration
A1370	Inspection and Allow Concrete (7000 Psi)	0%	5d	5d	16-Oct-15	20-Oct-15	-14d
A1380	Testing and Allow Concrete Curing	0%	30d	30d	21-Oct-15	19-Nov-15	-14d
A1390	Remove Forms and Curing for Precast Box Beam & Painting	0%	15d	15d	20-Nov-15	04-Dec-15	-14d
<b>WORK PHASE 1 - Relocation of Utilities</b>							
A1410	Survey, Staking, and Layout of New Utilities Final Location	30%	7d	5d	30-Mar-15 A	13-Jul-15	-48d
A1420	Excavate and Construct New Power Pedestal for House #1 @ Bile Area	100%	5d	0d	30-Mar-15 A	15-Jun-15 A	
A1430	Relocate/Install Affected Utility Electrical Meter & Associated Acc	90%	3d	0d	23-Jun-15 A	13-Jul-15	-48d
A1440	Relocate/Install MTS, Panelboard, Pullbox, & Other Elect/C	90%	7d	1d	23-Jun-15 A	14-Jul-15	-48d
A1450	Fabricate Precast/Post-tensioned Electrical Concrete Beam	0%	30d	30d	25-Jul-15	23-Aug-15	-59d
A1460	Construct Foundation/Column/Support Concrete Beam	0%	5d	5d	14-Aug-15	18-Aug-15	-59d
A1470	Install Power Primary Riser to Exst. Power Pole & Elec. Manho	0%	20d	20d	19-Aug-15	07-Sep-15	-59d
A1480	Construct Transformer Pad	0%	20d	20d	19-Aug-15	07-Sep-15	-59d
A1490	Prepare Power Outage Coordination Forms	0%	40d	40d	19-Aug-15	27-Sep-15	-59d
A1500	Erect Precast/Post-tensioned Electrical Beam	0%	5d	5d	24-Aug-15	28-Aug-15	-59d
A1510	Excavate Trenches, and Construction of Power & Comm. Du	0%	20d	20d	29-Aug-15	17-Sep-15	-59d
A1520	Install GPA Warning Tape and Pour Flowable Backfill	0%	4d	4d	14-Sep-15	17-Sep-15	-59d
A1530	Install/Pull Electrical Underground Line/System	0%	5d	5d	18-Sep-15	22-Sep-15	-59d
A1540	Prepare Electrical Cables & Power Accessories	0%	5d	5d	23-Sep-15	27-Sep-15	-59d
A1550	Power Outage I	0%	0d	0d	28-Sep-15		-59d
A1560	Disconnect/Connect Primary & Secondary Lines/Relocate L	0%	1d	1d	28-Sep-15	28-Sep-15	-59d
A1570	Energize Power Lines	0%	0d	0d		28-Sep-15	-59d
A1580	Remove Old Pole and Accessories	0%	10d	10d	29-Sep-15	08-Oct-15	105d
A1590	Demolition of Old Power Pedestal & Disposal	0%	6d	6d	09-Oct-15	14-Oct-15	105d
A1600	Submit and Approval Product Data/Shopdrawing to Comm. Agencies	0%	30d	30d	04-Aug-15	02-Sep-15	125d
A1610	Excavate and Install Handhole and Comm Shutter Box	0%	20d	20d	03-Sep-15	22-Sep-15	125d
A1620	Relocate of Communication Cables & Accessories (By Docomo)	0%	10d	10d	23-Sep-15	02-Oct-15	125d
A1630	Relocate of Communication Cables & Accessories (By GTA)	0%	10d	10d	03-Oct-15	12-Oct-15	125d
A1640	Underground Comm. Cable Pulling and Splicing Works	0%	7d	7d	13-Oct-15	19-Oct-15	125d
A1650	Disconnect Existing Communication Cables	0%	6d	6d	20-Oct-15	25-Oct-15	125d
A1660	Reconnect Communications Cables to New Lines	0%	6d	6d	26-Oct-15	31-Oct-15	125d
A1670	Pull-out/Remove Old Existing Cable, Conduit, and Secure	0%	6d	6d	01-Nov-15	06-Nov-15	125d
A1680	Testing and Commissioning of Electrical Equipment	0%	6d	6d	07-Nov-15	12-Nov-15	125d
<b>Waterline</b>							
A1690	Exploratory Survey for Existing Waterline Location	90%	12d	1d	04-May-15 A	12-Jul-15	99d
A1700	Submit Material and Shop Drawing to GWA & Approval	50%	21d	11d	18-May-15 A	23-Jul-15	99d
A1710	Provide Temporary Waterline Support for Pigua and Bile Area	0%	30d	30d	23-Jul-15	22-Aug-15	99d
A1720	Excavation for New & Temp. Water Line, Valves, and Lateral	0%	30d	30d	23-Jul-15	22-Aug-15	99d
A1730	Install New 6" Dia. DI and Temp. 6" Dia. PVC Pipe Water Line	0%	5d	5d	22-Aug-15	27-Aug-15	99d
A1740	Provide & Install New Service Lateral (1" Copper, 1" HDPE Pipe)	0%	7d	7d	27-Aug-15	03-Sep-15	99d

Remaining Level of Effort   
  Critical Remaining Work   
  Primary Baseline  
 Actual Work   
  Milestone  
 Remaining Work   
  Summary

**BILE/PIGUA BRIDGE REPLACEMENT (CONSTRUCTION PHASE)**  
**PROJECT UPDATED SCHEDULE (As of 06.30.2015)**

Date	Revision	Checked	Approved



Activity ID	Description	%	7d	7d	Start	End	99d	Notes
A1750	Install New Fire Hydrant, 6" Valves, & Water Meter	0%	7d	7d	03-Sep-15	10-Sep-15	99d	Install New Fire Hydrant, 6" Valves, & Water Meter
A1760	Install Perm. 6" Spool, 6"x8" DI Reducer, and 8" dia. Elbow Fittings	0%	5d	5d	10-Sep-15	15-Sep-15	99d	Install Perm. 6" Spool, 6"x8" DI Reducer, and 8" dia. Elbow Fittings
A1770	Provide Thrust Block at WL Bend Area (Where Required)	0%	8d	8d	15-Sep-15	23-Sep-15	99d	Provide Thrust Block at WL Bend Area (Where Required)
A1780	Pressure, Leak Testing, and Chlorination	0%	1d	1d	23-Sep-15	24-Sep-15	99d	Pressure, Leak Testing, and Chlorination
A1790	Prepare Water Outage Coordination Forms 1	0%	15d	15d	24-Sep-15	09-Oct-15	99d	Prepare Water Outage Coordination Forms 1
A1800	Water Outage 1 - Bile & Pigua Area	0%	0d	0d	09-Oct-15		99d	Water Outage 1 - Bile & Pigua Area
A1810	Install Permanent Transition Coupling (ACP to 6" DI Pipe)	0%	1d	1d	09-Oct-15	10-Oct-15	99d	Install Permanent Transition Coupling (ACP to 6" DI Pipe)
A1820	Connect Perm/Temp. WL to Exst. WL & Remove Exst WL &	0%	1d	1d	10-Oct-15	11-Oct-15	99d	Connect Perm/Temp. WL to Exst. WL & Remove Exst WL &
A1830	Water Energization - 1	0%	0d	0d		11-Oct-15	99d	Water Energization - 1
A1840	Backfilling, Install Warning Tape, and Adjust Affected Valve	0%	14d	14d	11-Oct-15	25-Oct-15	99d	Backfilling, Install Warning Tape, and Adjust Affected Valve
A1850	Provide and Install Valve Box and Box Cover	0%	10d	10d	25-Oct-15	04-Nov-15	99d	Provide and Install Valve Box and Box Cover
A1860	Install 6" Fire Hydrant Bollard	0%	7d	7d	04-Nov-15	11-Nov-15	99d	Install 6" Fire Hydrant Bollard
A1870	Install 6" dia. x 45 deg. Bend/Fittings	0%	5d	5d	11-Nov-15	16-Nov-15	99d	Install 6" dia. x 45 deg. Bend/Fittings
A1880	Install Angular Pipe Support to Edge of Box Beam	0%	6d	6d	22-Apr-16	27-Apr-16	-59d	Install Angular Pipe Support to Edge of Box Beam
A1890	Install 8" Dia. DI Pipe Permanent Waterline (Push on)	0%	5d	5d	28-Apr-16	02-May-16	-59d	Install 8" Dia. DI Pipe Permanent Waterline (Push on)
A1900	Install 6" x 8" DI Reducer, 6" & 8" x 45 deg. (Restrained) and	0%	5d	5d	30-Apr-16	04-May-16	-59d	Install 6" x 8" DI Reducer, 6" & 8" x 45 deg. (Restrained) and
A1910	Install Air Release Valves	0%	5d	5d	02-May-16	06-May-16	-59d	Install Air Release Valves
A1920	Provide Thrust Block at WL Bend Area (Where Required)	0%	5d	5d	06-May-16	10-May-16	-59d	Provide Thrust Block at WL Bend Area (Where Required)
A1930	Pressure, Leak Testing, and Chlorination	0%	1d	1d	11-May-16	11-May-16	-59d	Pressure, Leak Testing, and Chlorination
A1940	Water Outage 2 - Bile & Pigua Area	0%	0d	0d	12-May-16		-59d	Water Outage 2 - Bile & Pigua Area
A1950	Connect Permanent 8" Dia. WL to Exist 8" Dia. WL	0%	1d	1d	12-May-16	12-May-16	-59d	Connect Permanent 8" Dia. WL to Exist 8" Dia. WL
A1960	Water Energization - 2	0%	0d	0d		12-May-16	-59d	Water Energization - 2
A1970	Backfill, Install Warning Tape, & Compact/Restore	0%	2d	2d	13-May-16	14-May-16	-59d	Backfill, Install Warning Tape, & Compact/Restore
<b>WORK PHASE 2 - Downstream Side (PILES)</b>								
A1980	Saw Cutting and Removal of Asphalt Pavement	0%	2d	2d	07-Aug-15	09-Aug-15	-12d	Saw Cutting and Removal of Asphalt Pavement
A1990	Excavation/Preparation for Pile Driving Equipment Staging	0%	3d	3d	09-Aug-15	12-Aug-15	-12d	Excavation/Preparation for Pile Driving Equipment Staging
A2000	Mobilize Crane & Pile Driving Hammer (Position at North S	0%	1d	1d	29-Sep-15	29-Sep-15	-59d	Mobilize Crane & Pile Driving Hammer (Position at North S
A2010	Auger Holes and Install Steel Casing at Piles Location	0%	1d	1d	30-Sep-15	30-Sep-15	-59d	Auger Holes and Install Steel Casing at Piles Location
A2020	PC Pile Driving and Conduct Dynamic Pile Load Test (2 Piles)	0%	4d	4d	01-Oct-15	04-Oct-15	-59d	PC Pile Driving and Conduct Dynamic Pile Load Test (2 Piles)
A2030	Drive Steel Sheet Piles and Welding of Support at North Side	0%	2d	2d	05-Oct-15	06-Oct-15	-59d	Drive Steel Sheet Piles and Welding of Support at North Side
A2040	Travel and Position Crane at South Side of the Bridge	0%	1d	1d	07-Oct-15	07-Oct-15	-59d	Travel and Position Crane at South Side of the Bridge
A2050	Auger Holes and Install Steel Casing at Piles Location	0%	1d	1d	08-Oct-15	08-Oct-15	-59d	Auger Holes and Install Steel Casing at Piles Location
A2060	Drive Test Pile at South Side of the Bridge (2 Piles)	0%	4d	4d	09-Oct-15	13-Oct-15	-59d	Drive Test Pile at South Side of the Bridge (2 Piles)
A2070	Fab. & Del. of Remaining Prestressed Concrete Piles (Bile Ar	0%	28d	28d	13-Oct-15	09-Nov-15	-59d	Fab. & Del. of Remaining Prestressed Concrete Piles (Bile Ar
A2080	Drive Steel Sheet Piles and Welding of Support at South Side	0%	2d	2d	10-Nov-15	11-Nov-15	-59d	Drive Steel Sheet Piles and Welding of Support at South Side
A2090	Drive Production Piles at North Side of the Bridge (1 Pile)	0%	2d	2d	12-Nov-15	13-Nov-15	-59d	Drive Production Piles at North Side of the Bridge (1 Pile)
A2100	Drive Production Pile at South Side of the Bridge (2 Piles)	0%	4d	4d	14-Nov-15	17-Nov-15	-59d	Drive Production Pile at South Side of the Bridge (2 Piles)
A2120	Travel and Position Crane at North Side of the Bridge	0%	1d	1d	18-Nov-15	18-Nov-15	-59d	Travel and Position Crane at North Side of the Bridge

Remaining Level of Effort  
 Actual Work  
 Remaining Work  
 Critical Remaining Work  
 Primary Baseline  
 Milestone  
 Summary

**BILE/PIGUA BRIDGE REPLACEMENT (CONSTRUCTION PHASE)**  
**PROJECT UPDATED SCHEDULE (As of 06/30, 2015)**

Date	Revision	Checked	Approved



Activity ID	Description	%	Start	End	Start	End	Duration	Notes
A2130	Saw Cutting and Removal of Asphalt Pavement	0%	2d	2d	13-Oct-15	14-Oct-15	-59d	
A2140	Excavation/Preparation for Pile Driving Equipment Staging Area	0%	3d	3d	15-Oct-15	17-Oct-15	-59d	
A2150	Mobilize Crane & Pile Driving Equipment Staging Area	0%	2d	2d	18-Oct-15	19-Oct-15	-59d	
A2160	Auger Holes and Install Steel Casing at Piles Location	0%	1d	1d	20-Oct-15	20-Oct-15	-59d	
A2170	PC Pile Driving and Conduct Dynamic Pile Load Test (2 Piles)	0%	8d	8d	21-Oct-15	28-Oct-15	-59d	
A2180	Drive Steel Sheet Piles and Welding of Support at North Side	0%	2d	2d	29-Oct-15	30-Oct-15	-59d	
A2190	Travel and Position Crane at South Side of the Bridge	0%	1d	1d	31-Oct-15	31-Oct-15	-59d	
A2200	Auger Holes and Install Steel Casing at Piles Location	0%	1d	1d	01-Nov-15	01-Nov-15	-59d	
A2210	Drive Test Pile at South Side of the Bridge (2 Piles)	0%	8d	8d	02-Nov-15	09-Nov-15	-59d	
A2220	Fab & Del. of Remaining Prestressed Concrete Piles (Pigua /	0%	28d	28d	10-Nov-15	07-Dec-15	-59d	
A2230	Drive Steel Sheet Piles and Welding of Support at South Side	0%	2d	2d	08-Dec-15	09-Dec-15	-59d	
A2240	Drive Production Pile at South Side of the Bridge (2 Piles)	0%	9d	9d	10-Dec-15	18-Dec-15	-59d	
A2250	Drive Production at North Side of the Bridge (2 Piles)	0%	10d	10d	19-Dec-15	28-Dec-15	-59d	
A2260	Travel and Position Crane at North Side of the Bridge	0%	1d	1d	29-Dec-15	29-Dec-15	-59d	
<b>WORK PHASE 3 - Upstream Side (PILES/PILE CAPS)</b>								
A2270	Re-route Traffic to New Temporary Steel Bridge at Downstre	0%	1d	1d	19-Nov-15	19-Nov-15	-59d	
A2280	Prepare Pile Driving Equipment Staging Area	0%	2d	2d	20-Nov-15	21-Nov-15	-59d	
A2290	Auger Holes and Install Steel Casing at Piles Location	0%	1d	1d	22-Nov-15	22-Nov-15	-59d	
A2300	Drive Production Pile at North Side of the Bridge (3 Piles)	0%	5d	5d	23-Nov-15	27-Nov-15	-59d	
A2310	Mobilize and Position Crane at South Side of the Bridge	0%	1d	1d	28-Nov-15	28-Nov-15	-59d	
A2320	Auger Holes and Install Steel Casing at Piles Location	0%	1d	1d	29-Nov-15	29-Nov-15	-59d	
A2330	Drive Production Pile at South Side of the Bridge (2 Piles)	0%	8d	8d	30-Nov-15	07-Dec-15	-59d	
A2340	Monitor Sewer Manhole During Pile Driving	0%	8d	8d	30-Nov-15	07-Dec-15	-59d	
A2350	Sawcut AC Pavement and Excavation for Pile Cap Structures	0%	4d	4d	08-Dec-15	11-Dec-15	-59d	
A2360	Cut-off Piles to Required Elevation and Dispose Excess Piles	0%	2d	2d	12-Dec-15	13-Dec-15	-59d	
A2370	Excavation and Trimming Works for Pile Cap Base	0%	3d	3d	12-Dec-15	14-Dec-15	-59d	
A2380	Gravel Bedding, Compaction, and Pour Lean Concrete for Pi	0%	2d	2d	15-Dec-15	16-Dec-15	-59d	
A2390	Rebar, Forms, and Pour Concrete for Half of the Pile Cap	0%	15d	15d	17-Dec-15	31-Dec-15	-59d	
A2400	Remove Forms and Curing of Pile cap Structures	0%	5d	5d	01-Jan-16	05-Jan-16	-59d	
A2410	Demolish Half of the Existing Abutment and Disposal	0%	5d	5d	05-Jan-16	10-Jan-16	-59d	
A2420	Backfilling, Compaction, and Trimming for Riprap Location	0%	4d	4d	11-Jan-16	14-Jan-16	-59d	
A2430	Deliver/Install Riprap Boulders, & Remove Exst at Upstrea	0%	8d	8d	15-Jan-16	22-Jan-16	26d	
<b>Pigua Bridge Area</b>								
A2440	Re-route Traffic to New Temporary Steel Bridge at Downstre	0%	1d	1d	30-Dec-15	30-Dec-15	-59d	
A2450	Prepare Pile Driving Equipment Staging Area	0%	2d	2d	30-Dec-15	31-Dec-15	-59d	
A2460	Auger Holes and Install Steel Casing at Piles Location	0%	1d	1d	01-Jan-16	01-Jan-16	-59d	
A2470	Drive Production Pile at North Side of the Bridge (2 Piles)	0%	8d	8d	02-Jan-16	09-Jan-16	-59d	
A2480	Mobilize and Position Crane at South Side of the Bridge	0%	1d	1d	10-Jan-16	10-Jan-16	-59d	
A2490	Auger Holes and Install Steel Casing at Piles Location	0%	1d	1d	11-Jan-16	11-Jan-16	-59d	

<ul style="list-style-type: none"> <li>▬ Remaining Level of Effort</li> <li>▬ Actual Work</li> <li>▬ Remaining Work</li> </ul>	<ul style="list-style-type: none"> <li>▬ Critical Remaining Work</li> <li>◆ Milestone</li> <li>▬ Summary</li> </ul>	<ul style="list-style-type: none"> <li>▬ Primary Baseline</li> </ul>	<b>BILE/PIGUA BRIDGE REPLACEMENT (CONSTRUCTION PHASE)</b> <b>PROJECT UPDATED SCHEDULE (As of 06.30, 2015)</b>	<table border="1"> <tr> <th>Date</th> <th>Revision</th> <th>Checked</th> <th>Approved</th> </tr> <tr> <td> </td> <td> </td> <td> </td> <td> </td> </tr> </table>	Date	Revision	Checked	Approved				
Date	Revision	Checked	Approved									



Project Name: Bile / Pigua Bridge Replacement (Construction Phase)  
 Contract No.: GU-NH-NBIS(007)

Date: 30-Jun-15

Run Date: 30-Jun-15

Activity ID	Description	%	Start	End	Start	End	Duration	ES	EF	LS	LF	SS	FF	LAG	Lead	Lag
A2500	Drive Production Pile at South Side of the Bridge (2 Piles)	0%	8d	8d	12-Jan-16	19-Jan-16	-59d									
A2510	Sawcut AC Pavement and Excavation for Pile Cap Structures	0%	1d	1d	20-Jan-16	20-Jan-16	-59d									
A2520	Cut-off Piles to Required Elevation and Dispose Excess Piles	0%	2d	2d	20-Jan-16	21-Jan-16	-59d									
A2530	Excavation and Trimming Works for Pile Cap Base	0%	3d	3d	20-Jan-16	22-Jan-16	-59d									
A2540	Gravel Bedding, Compaction, and Pour Lean Concrete for Pile	0%	2d	2d	23-Jan-16	24-Jan-16	-59d									
A2550	Rebar, Forms, and Pour Concrete for Half of the Pile Cap	0%	15d	15d	23-Jan-16	08-Feb-16	-59d									
A2560	Remove Forms and Curing of Pile cap Structures	0%	4d	4d	09-Feb-16	12-Feb-16	-59d									
A2570	Demolish Half of the Existing Abutment and Disposal	0%	5d	5d	09-Feb-16	13-Feb-16	-59d									
A2580	Backfilling, Compaction, and Trimming for Riprap Location	0%	4d	4d	09-Feb-16	12-Feb-16	-59d									
A2590	Deliver/Install Riprap Boulders, & Remove Exst at Upstream	0%	8d	8d	13-Feb-16	20-Feb-16	-59d									
<b>WORK PHASE 4 - Upstream Side (BRIDGE DECK)</b>																
A2600	Excavate Roadway for Concrete Approach	0%	2d	2d	15-Jan-16	16-Jan-16	-59d									
A2610	Adjust Sewer Manhole, Frame, and Manhole Cover	0%	5d	5d	15-Jan-16	19-Jan-16	-59d									
A2620	Backfilling, Leveling, and Compaction for Concrete Approach	0%	3d	3d	15-Jan-16	17-Jan-16	-59d									
A2630	Rebars, Forms, and Pour Concrete for Wingwall	0%	4d	4d	15-Jan-16	18-Jan-16	-59d									
A2640	Deliver and Erect 4 Units Precast/Prestressed Box Beams & #	0%	7d	7d	19-Jan-16	23-Jan-16	-59d									
A2650	Install Transverse Post Tensioning at Precast Box beam Mids	0%	3d	3d	23-Jan-16	25-Jan-16	-59d									
A2660	Rebars, Forms, and Pour Concrete for Reinforced Concrete A	0%	5d	5d	26-Jan-16	30-Jan-16	-59d									
A2670	Construct Concrete Curb	0%	5d	5d	31-Jan-16	04-Feb-16	-59d									
A2680	Rebars, Forms, and Pour Concrete for Side Concrete Barriers	0%	8d	8d	05-Feb-16	12-Feb-16	-59d									
A2690	Construct Embankment	0%	3d	3d	13-Feb-16	15-Feb-16	-59d									
A2700	Install Drainage and Construct Headwall	0%	15d	15d	13-Feb-16	27-Feb-16	-59d									
A2710	Construct Bio-swale and Maintenance	0%	8d	8d	20-Feb-16	27-Feb-16	-59d									
A2720	Water Blast in Preparation of AC Pavement	0%	2d	2d	28-Feb-16	29-Feb-16	-59d									
A2730	Place & Compact Aggregate Base Course (193 CY)	0%	5d	5d	28-Feb-16	03-Mar-16	-59d									
A2740	Tack Coat and Hot Mix (HMA) Concrete Pavement Applicat	0%	3d	3d	04-Mar-16	06-Mar-16	-59d									
A2750	Install Quadrant Anchorage Trailing End & Approach End	0%	7d	7d	07-Mar-16	13-Mar-16	-30d									
A2760	Install Guardrail (Type W & Type T)	0%	7d	7d	14-Mar-16	20-Mar-16	-30d									
<b>BILE BRIDGE AREA</b>																
A2770	Excavate Roadway for Concrete Approach	0%	2d	2d	13-Feb-16	14-Feb-16	-59d									
A2775	Adjust Sewer Manhole, Frame, and Manhole Cover	0%	5d	5d	13-Feb-16	17-Feb-16	-59d									
A2780	Backfilling, Leveling, and Compaction for Concrete Approach	0%	3d	3d	13-Feb-16	15-Feb-16	-59d									
A2790	Rebars, Forms, and Pour Concrete for Wingwall	0%	4d	4d	13-Feb-16	16-Feb-16	-59d									
A2800	Deliver and Erect 4 Units Precast/Prestressed Box Beams & #	0%	7d	7d	17-Feb-16	23-Feb-16	-59d									
A2810	Install Transverse Post Tensioning at Precast Box beam Mids	0%	3d	3d	21-Feb-16	23-Feb-16	-59d									
A2820	Rebars, Forms, and Pour Concrete for Reinforced Concrete A	0%	5d	5d	24-Feb-16	28-Feb-16	-59d									
A2830	Construct Concrete Curb	0%	5d	5d	24-Feb-16	28-Feb-16	-59d									
A2840	Rebars, Forms, and Pour Concrete for Side Concrete Barriers	0%	8d	8d	29-Feb-16	07-Mar-16	-59d									
A2850	Construct Embankment	0%	3d	3d	29-Feb-16	02-Mar-16	-59d									
<b>PIGUA BRIDGE AREA</b>																

Remaining Level of Effort    
  Critical Remaining Work    
  Primary Baseline  
 Actual Work    
 ◆ Milestone    
  Summary  
 Remaining Work

**BILE/PIGUA BRIDGE REPLACEMENT (CONSTRUCTION PHASE)**  
**PROJECT UPDATED SCHEDULE (As of 06.30, 2015)**

Date	Revision	Checked	Approved



Project Name: Bile / Pigua Bridge Replacement (Construction Phase)  
 Contract No.: GU-NH-NBIS(007)

Data Date: 30-Jun-15

Run Date: 30-Jun-15

Activity ID	Description	%	Start	End	Start	End	Duration	ES	EF	LS	LF	SS	SE	LF	Activity Name
A2860	Construct Bio-swale and Maintenance	0%	8d	8d	29-Feb-16	07-Mar-16	-59d								Construct Bio-swale and Maintenance
A2870	Water Blast in Preparation of AC Pavement	0%	2d	2d	08-Mar-16	09-Mar-16	-59d								Water Blast in Preparation of AC Pavement
A2880	Place & Compact Aggregate Base Course (136 CY)	0%	3d	3d	08-Mar-16	10-Mar-16	-59d								Place & Compact Aggregate Base Course (136 CY)
A2890	Tack Coat and Hot Mix (HMA) Concrete Pavement Applicat	0%	3d	3d	11-Mar-16	13-Mar-16	-59d								Tack Coat and Hot Mix (HMA) Concrete Pavement Applicat
A2900	Install Guardrail Anchorage Trailing End & Approach End	0%	7d	7d	21-Mar-16	27-Mar-16	-30d								Install Guardrail Anchorage Trailing End & Approach End
A2910	Install Guardrail (Type W & Type T)	0%	7d	7d	28-Mar-16	03-Apr-16	-30d								Install Guardrail (Type W & Type T)
<b>WORK PHASE 5 - Downstream Side (PILE CAPS)</b>															
A2920	Sawcut AC Pavement and Excavation for Pile Cap Structures	0%	1d	1d	07-Mar-16	07-Mar-16	-59d								Sawcut AC Pavement and Excavation for Pile Cap Structures
A2930	Remove Sheet Piles and dispose offsite	0%	5d	5d	08-Mar-16	12-Mar-16	-59d								Remove Sheet Piles and dispose offsite
A2940	Cut-off Piles to Required Elevation and Dispose Excess Piles	0%	2d	2d	08-Mar-16	09-Mar-16	-59d								Cut-off Piles to Required Elevation and Dispose Excess Piles
A2950	Excavation and Trimming Works for Pile Cap Base	0%	2d	2d	08-Mar-16	09-Mar-16	-59d								Excavation and Trimming Works for Pile Cap Base
A2960	Gravel Bedding, Compaction, and Pour Lean Concrete for Pi	0%	2d	2d	10-Mar-16	11-Mar-16	-59d								Gravel Bedding, Compaction, and Pour Lean Concrete for Pi
A2970	Water Blast Construction Joint and Install Dowel Bars to Co	0%	2d	2d	12-Mar-16	13-Mar-16	-59d								Water Blast Construction Joint and Install Dowel Bars to Co
A2980	Rebar, Forms, and Pour Concrete for Half of the Pile Cap	0%	15d	15d	12-Mar-16	26-Mar-16	-59d								Rebar, Forms, and Pour Concrete for Half of the Pile Cap
A2990	Remove Forms and Curing of Pile cap Structures	0%	5d	5d	27-Mar-16	31-Mar-16	-59d								Remove Forms and Curing of Pile cap Structures
A3000	Demolish Half of the Existing Abutment and Disposal	0%	5d	5d	27-Mar-16	31-Mar-16	-59d								Demolish Half of the Existing Abutment and Disposal
A3010	Backfilling, Compaction, and Trimming for Riprap Location	0%	2d	2d	01-Apr-16	02-Apr-16	-59d								Backfilling, Compaction, and Trimming for Riprap Location
A3020	Deliver/Install Riprap Boulders, & Remove Exst at Downstr	0%	10d	10d	01-Apr-16	10-Apr-16	-35d								Deliver/Install Riprap Boulders, & Remove Exst at Downstr
<b>WORK PHASE 5 - Downstream Side (PILE CAPS)</b>															
A3030	Sawcut AC Pavement and Excavation for Pile Cap Structures	0%	1d	1d	14-Mar-16	14-Mar-16	-59d								Sawcut AC Pavement and Excavation for Pile Cap Structures
A3040	Remove Sheet Piles and dispose offsite	0%	5d	5d	15-Mar-16	19-Mar-16	-59d								Remove Sheet Piles and dispose offsite
A3050	Cut-off Piles to Required Elevation and Dispose Excess Piles	0%	2d	2d	15-Mar-16	16-Mar-16	-59d								Cut-off Piles to Required Elevation and Dispose Excess Piles
A3060	Excavation and Trimming Works for Pile Cap Base	0%	2d	2d	15-Mar-16	16-Mar-16	-59d								Excavation and Trimming Works for Pile Cap Base
A3070	Gravel Bedding, Compaction, and Pour Lean Concrete for Pi	0%	2d	2d	15-Mar-16	16-Mar-16	-59d								Gravel Bedding, Compaction, and Pour Lean Concrete for Pi
A3080	Water Blast Construction Joint and Install Dowel Bars to Co	0%	2d	2d	17-Mar-16	18-Mar-16	-59d								Water Blast Construction Joint and Install Dowel Bars to Co
A3090	Rebar, Forms, and Pour Concrete for Half of the Pile Cap	0%	15d	15d	17-Mar-16	31-Mar-16	-59d								Rebar, Forms, and Pour Concrete for Half of the Pile Cap
A3100	Remove Forms and Curing of Pile cap Structures	0%	4d	4d	01-Apr-16	04-Apr-16	-59d								Remove Forms and Curing of Pile cap Structures
A3110	Demolish Half of the Existing Abutment and Disposal	0%	5d	5d	01-Apr-16	05-Apr-16	-59d								Demolish Half of the Existing Abutment and Disposal
A3120	Backfilling, Compaction, and Trimming for Riprap Location	0%	2d	2d	03-Apr-16	04-Apr-16	-59d								Backfilling, Compaction, and Trimming for Riprap Location
A3130	Deliver/Install Riprap Boulders, & Remove Exst at Downstr	0%	10d	10d	11-Apr-16	20-Apr-16	-35d								Deliver/Install Riprap Boulders, & Remove Exst at Downstr
<b>WORK PHASE 6 - Downstream Side (BRIDGE DECK)</b>															
A3140	Excavate Roadway for Concrete Approach (1800 CY)	0%	2d	2d	03-Apr-16	04-Apr-16	-59d								Excavate Roadway for Concrete Approach (1800 CY)
A3150	Backfilling, Leveling, and Compaction for Concrete Approach	0%	3d	3d	05-Apr-16	05-Apr-16	-59d								Backfilling, Leveling, and Compaction for Concrete Approach
A3160	Rebars, Forms, and Pour Concrete for Wingwall	0%	4d	4d	03-Apr-16	06-Apr-16	-59d								Rebars, Forms, and Pour Concrete for Wingwall
A3165	Install Drainage and Construct Headwall	0%	17d	17d	03-Apr-16	19-Apr-16	-59d								Install Drainage and Construct Headwall
A3170	Deliver and Erect 5 Units Precast/Prestressed Box Beams & /	0%	7d	7d	07-Apr-16	13-Apr-16	-59d								Deliver and Erect 5 Units Precast/Prestressed Box Beams & /
A3180	Install Transverse Post Tensioning at Precast Box beam Mid	0%	4d	4d	10-Apr-16	13-Apr-16	-59d								Install Transverse Post Tensioning at Precast Box beam Mid
A3190	Rebars, Forms, and Pour Concrete for Reinforced Concrete A	0%	5d	5d	12-Apr-16	16-Apr-16	-59d								Rebars, Forms, and Pour Concrete for Reinforced Concrete A

Remaining Level of Effort    
  Critical Remaining Work    
  Primary Baseline  
 Actual Work    
 ◆ Milestone  
 Remaining Work    
 ▼ Summary

**BILE/PIGUA BRIDGE REPLACEMENT (CONSTRUCTION PHASE)**  
**PROJECT UPDATED SCHEDULE (As of 06.30. 2015)**

Date	Revision	Checked	Approved



Activity ID	Description	%	ES	EF	LS	LF	Duration	Start	End	Notes
A3200	Construct Concrete Curb	0%	5d	5d	17-Apr-16	21-Apr-16	-59d			Construct Concr
A3210	Rebar, Forms, and Pour Concrete for Side Concrete Barriers	0%	6d	6d	17-Apr-16	22-Apr-16	-59d			Rebar, Forms, a
A3220	Construct Embankment	0%	3d	3d	17-Apr-16	19-Apr-16	-59d			Construct Emban
A3230	Construct Bio-swale and Maintenance	0%	5d	5d	20-Apr-16	24-Apr-16	-59d			Construct Bio-s
A3240	Water Blast in Preparation of AC Pavement	0%	1d	1d	23-Apr-16	25-Apr-16	-59d			Water Blast in I
A3250	Place & Compact Aggregate Base Course (193 CY)	0%	3d	3d	25-Apr-16	27-Apr-16	-59d			Place & Compa
A3260	Tack Coat and Hot Mix (HMA) Concrete Pavement Applicat	0%	3d	3d	28-Apr-16	30-Apr-16	-59d			Tack Coat and
A3280	Install Guardrail Anchorage Trailing End & Approach End	0%	7d	7d	01-May-16	07-May-16	-57d			Install Guard
A3290	Install Guardrail (Type W & Type T)	0%	7d	7d	01-May-16	07-May-16	-57d			Install Guard
Pigua Bri										
A3300	Excavate Roadway for Concrete Approach (1000 CY)	0%	2d	2d	05-Apr-16	06-Apr-16	-59d			Excavate Roadway f
A3310	Backfilling, Leveling, and Compaction for Concrete Approach	0%	3d	3d	05-Apr-16	07-Apr-16	-59d			Backfilling, Levelin
A3320	Rebar, Forms, and Pour Concrete for Wingwall	0%	4d	4d	05-Apr-16	08-Apr-16	-59d			Rebar, Forms, and P
A3330	Deliver and Erect 6 Units Precast/Prestressed Box Beams & /	0%	8d	8d	09-Apr-16	16-Apr-16	-59d			Deliver and Erect
A3340	Install Transverse Post Tensioning at Precast Box beam Mids	0%	4d	4d	13-Apr-16	16-Apr-16	-58d			Install Transverse
A3350	Rebar, Forms, and Pour Concrete for Reinforced Concrete A	0%	5d	5d	17-Apr-16	21-Apr-16	-59d			Rebar, Forms, at
A3360	Construct Concrete Curb	0%	3d	3d	22-Apr-16	24-Apr-16	-59d			Construct Concr
A3370	Rebar, Forms, and Pour Concrete for Side Concrete Barriers	0%	6d	6d	22-Apr-16	27-Apr-16	-59d			Rebar, Forms, Conc
A3380	Construct Embankment	0%	3d	3d	22-Apr-16	24-Apr-16	-59d			Construct Emban
A3390	Construct Bio-swale and Maintenance	0%	5d	5d	22-Apr-16	26-Apr-16	-59d			Construct Bio-s
A3400	Water Blast in Preparation of AC Pavement	0%	2d	2d	25-Apr-16	26-Apr-16	-59d			Water Blast in I
A3410	Place & Compact Aggregate Base Course (136 CY)	0%	3d	3d	25-Apr-16	27-Apr-16	-59d			Place & Compa
A3420	Tack Coat and Hot Mix (HMA) Concrete Pavement Applicat	0%	3d	3d	28-Apr-16	30-Apr-16	-59d			Tack Coat and
A3430	Install Guardrail Anchorage Trailing End & Approach End	0%	7d	7d	06-May-16	12-May-16	-57d			Install Gua
A3440	Install Guardrail (Type W & Type T)	0%	7d	7d	06-May-16	12-May-16	-57d			Install Gua
A3450	Install Pavement and Raise Pavement Markings	0%	3d	3d	15-May-16	17-May-16	-59d			Install Pa
CLOS										
A4000	Restoration of Affected Structures and Clean-up	0%	4d	4d	15-May-16	18-May-16	-59d			Restorati
A4005	Establish Turf (1000 SY)	0%	3d	3d	15-May-16	17-May-16	-59d			Establish
A4010	Establish Punch-out Items	0%	4d	4d	18-May-16	21-May-16	-59d			Establish
A4020	Punchlists Inspection and Corrections	0%	5d	5d	21-May-16	25-May-16	-59d			Punchl
A4030	Final Inspection and Corrections	0%	3d	3d	24-May-16	26-May-16	-59d			Final I
A4040	Acceptance and Turn-over to Government	0%	1d	1d	27-May-16	27-May-16	-59d			Accept
A4050	Project Complete (CCD - March 29, 2016)	0%	0d	0d		27-May-16	-59d			Project

Remaining Level of Effort    
  Critical Remaining Work    
  Primary Baseline  
 Actual Work    
 ◆ Milestone  
 Remaining Work    
 ▼ Summary

**BILE/PIGUA BRIDGE REPLACEMENT (CONSTRUCTION PHASE)**  
**PROJECT UPDATED SCHEDULE (As of 06.30.2015)**

Date	Revision	Checked	Approved

# ATTACHMENT F



<b>Transmittal/Review/Approval</b>		FILE NAME: Letter: Bile/Pigua Bridge Project GU-NH-NBIS(007)	DATE: 5/28/2015		
CONTRACT NO.: GU-NH-NBIS(007)		TITLE: (Fill in Project Title/Location Here) Bile / Pigua Bridge Replacement (Construction Phase), Route 4, Merizo, Guam			
FROM (CONTRACTOR): Korando Corporation		TO: Mr. Glenn Leon Guerrero / DPW	SUBMITTAL NO.: SPECS. SECTION:		
ENCL. NO.	NO. OF COPIES	DESCRIPTION	SPEC.SEC./PARA	SCHEDULE ACTIVITY NO.	CQC CODE
		Bile & Pigua Bridge Replacement (Construction Phase)			
1	2	Letter: Bile/Pigua Bridge Project GU-NH-NBIS(007)			
2	18	Existing Bridge Assessment Report			
DATE NEEDED BY:					
TRANSMITTED FOR: <input type="checkbox"/> APPROVAL <input type="checkbox"/> CLARIFICATION <input type="checkbox"/> SELECTION <input checked="" type="checkbox"/> RECORD <input type="checkbox"/> VARIANCE					
It is hereby certified that the material submitted herein conforms to contract requirements and can be installed in the allocated spaces.		CONTRACTOR'S REPRESENTATIVE NAME/TITLE Ricarte Bisquera / QC Manager	SIGNATURE:		
Received By (Print Name & Sign)/Date/Time: Mr. Glenn Leon Guerrero / DPW    5/28/2015					
FROM:		SIGNATURE:		DATE:	
TO: Mr. Glenn Leon Guerrero / DPW		For review/comment ( ) copies of enclosures forwarded. RETURN WITHIN ( ) WORKING DAYS, unless submittal is for record/info purposes only and there are no adverse comments.			
Received By (Print Name & Sign)/Date/Time: Mr. Glenn Leon Guerrero / DPW    5/28/2015					
FROM:		TO:		DATE:	
RECOMMEND / Enclosure(s) is (are):					
<input type="checkbox"/> No Exception Taken (NET)		<input type="checkbox"/> Rejected/Resubmit (Rej/R)		<input type="checkbox"/> _____	
<input type="checkbox"/> Exceptions As Noted (EAN)		<input type="checkbox"/> No Action Required (NAR)		<input type="checkbox"/> _____	
<input type="checkbox"/> Revise/Resubmit (Rev/R)		<input type="checkbox"/> Not Subject To Review (NSTR)			
REMARKS:					
Copy to: <input type="checkbox"/> Copies of encls returned:		SIGNATURE: _____			
Received By (Print Name & Sign)/Date/Time:					

*Rec'd - 5/29/15*  
*7:36 a.m.*  
*Cel JAVIER*



**KORANDO CORPORATION**  
**GENERAL CONTRACTOR**

P.O. BOX 20536  
GMF, GUAM 96921  
TEL: (671) 649-7880  
(671) 649-7881  
FAX: (671) 649-7882  
EMAIL: admin\_korando@taleguam.net

May 27, 2015

Department of Public Works  
542 N. Marine Drive Corps.  
Tamuning, Guam 96913  
Attn: Director- Glenn Leon Guerrero

Re: Bile/Pigua Bridge Project GU-NH-NBIS (007)

Dear Mr. Glenn Leon Guerrero,

Respectfully, we understand the concerns regarding the delay on the Bile-Pigua project. We would like to assure you that Korando Corporation is going to provide the best solution to recover the loss of time that has accumulated in the past few months. We understand there seems to be no accomplishment or physical construction movement for the Bridge project. Behind the scenes we are working on this. We are committed to the effort of bringing the project up to where we should be.

And, we call your attention to the following issues we are having with for the Bile-Pigua Bridge project.

1<sup>st</sup> - Building permit received on November 2014. Yes, a building permit was dated and received. However, individual agency compliance requirement that permits actual start of work was not completed until 02/26/2015. This was part of the set back on compliance requirements which provided a delay for actual work to start at the construction site. And, that the project document is fair to state that these agency compliance associated with permitting is not included in the 450 contract calendar days.

2<sup>nd</sup> - Recovery Schedule- (Alternate Phasing Issue) recovery schedule has been submitted for review and are awaiting approval to proceed with this phasing.

3<sup>rd</sup> - Resident Complaints- We have encountered complaints from a local resident that should Korando proceed with its construction, he will be pressing legal charges. This issue was submitted on RFI #9 to Stanley Consultants. Korando received a letter from DPW dated May 20, 2015 acknowledging and resolving the complaint issue.

4<sup>th</sup> - Alternate Phasing Plan RFI #11 Stanley Consultants response letter to Korando dated May 5, 2015. It was stated by Stanley Consultants that we must preserve and protect the existing structures as indicated in Section 107.02 of FP-03. Our main concern for the alternate phasing is the efficiency of the bridge in general and the safety of the public, in particular. Korando Corporation has researched from prior data back in 2008 from Geo-Engineering & Testing, Inc with regards to the structural integrity that the construction of a temporary single lane bridge be a temporary interim solution. And, to date, an updated research from J.M Aquino and Associates indicated that the current temporary bridge is not safe. And, the same findings recommend an alternate phasing plan be explored instead of the current phasing plan.

KORANDO CORPORATION

We hope you are able to consider that this is not a means of convenience for Korando Corporation but the efficiency of the existing bridge structures and welfare and safety to the public. Korando Corporation is handling the construction of the bridges as a main priority to the Government of Guam and its people. We welcome any suggestions or references that you are able to offer with the utmost respect.

Sincerely,



Byong Ho Kim  
President



J.M. AQUINO, PC

Consulting Engineers

278 Scout Marine Corps Drive, Suite 206 Hengi Plaza, Tamuning 96913  
P.O. Box 6052 Tamuning, Guam 96931

Tel 647-5124 Fax 647-5123  
e-mail: johnny.a@jmapc.net

**STRUCTURAL ASSESSMENT REPORT**  
**FOR EXISTING BILE & FIGUA STEEL BRIDGE**

MERIZO, GUAM

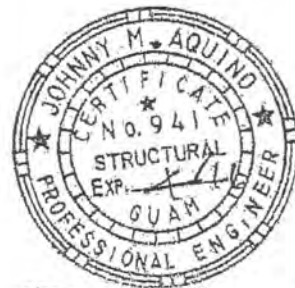

*[Handwritten signature]* 5-26-15

## ANALYSIS & DESIGN CRITERIA

### A. REFERENCES:

1. American Association of State Highways & Transportation Officials, AASHTO 2012
2. American Institute of Steel Construction, AISC 2005

### B. MATERIALS:

Structural Steel Shapes & Plates .....36 ksi (assumed)  
Deck plates (3/4" thick)

### C. LOADS:

#### CASE 1:

- a. HS20-44 Truck Load
- b. Lane Load  
P = 18 kips (*for Moment*)  
= 26 kips (*for Shear*)  
w = 0.64 kips/ft

#### CASE 2:

- a. Lowboy Trailer + Crane Counterweight  
Truck Tractor Weight = 15 kips  
Lowboy Trailer Weight = 17 kips  
Crane Counterweight = 74 kips  
Mobile Crane = 63 kips

Lowboy Trailer + Crane Counterweight = 91 Kips (govern design)

### 2. Seismic Load

Design Parameters :

Site Class = 'E'

$F_{pga}$  = 1.08 (*Site Factor @ Zero-Period on Acceleration Spectrum*)

$F_a$  = 0.90 (*Site Factor for Short-Period Range of Acceleration Spectrum*)

$F_v$  = 2.40 (*Site Factor for Long-Period Range of Acceleration Spectrum*)

$S_s$  = 1.50g (*Mapped Spectral Response Acceleration @ 0.20-sec. period*)

$S_1$  = 0.60g (*Mapped Spectral Response Acceleration @ 1.0-sec. period*)

PGA = 0.34g (*Peak Ground Acceleration*)

## EXECUTIVE SUMMARY

The following report presents the structural assessment of the superstructures (structural steel stringers and steel plates) of the two existing bridges; namely, Bile and Pigua Bridge. Both bridges are located next to each other along Route 4 Road in Merizo. We understand that existing bridge substructure are structurally sufficient to support the existing and temporary bridges.

Results of the analysis confirmed that the existing bridge superstructures are structurally inadequate to support the two design load Cases 1(HS20-44) and 2 (Lowboy Trailer + Crane Counterweight). AASHTO LRFD requirements are not met.

## DISCUSSION:

### CASE 1: (HS20-44 TRUCK LOAD AND LANE LOAD)

The design loads are the various combinations of HS20-44 Truck Load, Lane Load and Seismic Load. The dead load weight of 3/4" thick deck plates and I-beam stringers were also considered in the analysis. Stringer section properties, spacing, and actual dimensions of the existing bridge were measured for use in the evaluation. Load and Resistance Factor Design (LRFD) was used to determine the strength capacity of the superstructure bridge components. The design stresses were then compared with the AASHTO allowable stresses (moment and shear) to find out whether the structure is adequate or not.

### CASE 2: (LOWBOY TRAILER + CRANE COUNTERWEIGHT)

The design loads are the combination of Lowboy Trailer Weight + Crane Counterweight and Seismic Load. The various vertical design loads were provided to us by the Contractor.



CASE I :

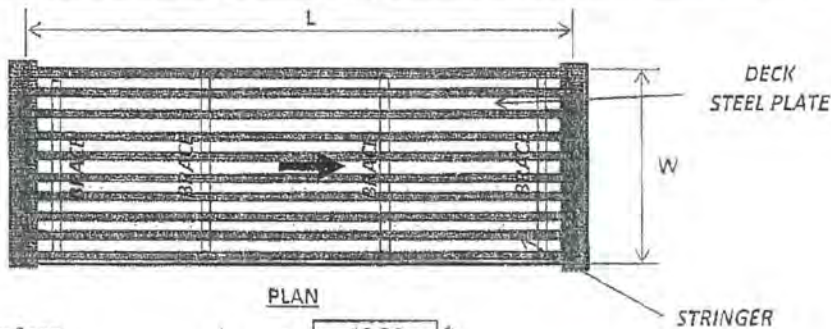

Bridge Span	L	=	19.00	ft
Bridge Width	W	=	12.00	ft
Live Load Type		=	HS20-44	

A. LOADINGS

LANE LOAD

Concentrated Load	=	18.00	kips
		26.00	kips
Uniform Load	=	0.64	kips/ft

AASHTO 3.6.1.2.4  
 (for Moment)  
 (for Shear)

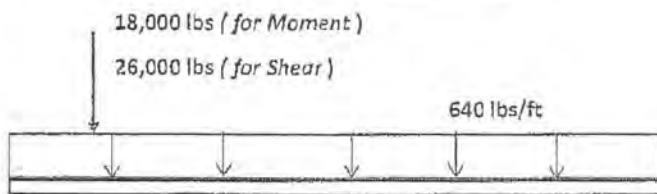

LOADING DIAGRAM

TRUCK LOAD

HS20-44	=	72.00	kips
---------	---	-------	------

AASHTO 3.6.1.2.2

(Total Weight of Vehicle)

Axle Width	=	6.00	ft
Axle Spacing	=	14.00	ft
v	=	14.00	ft

(Front Wheel to 1st Rear Wheel)  
 (1st Rear Wheel to 2nd Rear Wheel)

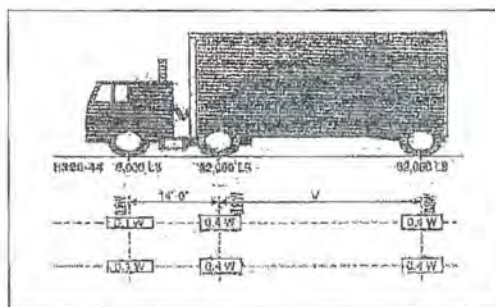

## B. DECK PLATE DESIGN

Deck Plate Properties:

Plate Thickness	$t$	=	0.75	in
Plate Width	$v$	=	20.00	in
Moment of Inertia	$I$	=	0.70	in <sup>4</sup>
Section Modulus	$S$	=	1.88	in <sup>3</sup>
Yield Strength	$F_y$	=	36.00	ksi

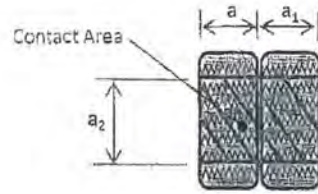

Truck Wheel

Wheel Contact Width	$a_1$	=	10.0	in
Wheel Contact Length	$a_2$	=	20.0	in

AASHTO 3.6.1.2.5

Dyn. Load Allowance	I.M.	=	0.33
---------------------	------	---	------

AASHTO 3.6.2

Deadload

Deck Plate Weight	$w_p$	=	0.05	kips/ft
-------------------	-------	---	------	---------

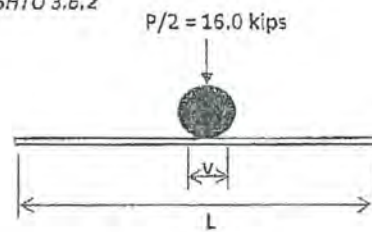

Liveload

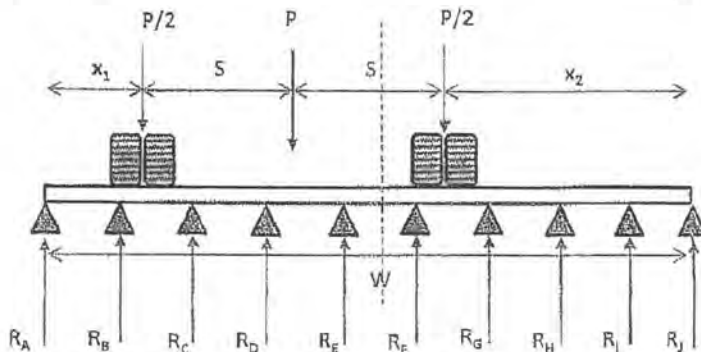

$P$	=	32.00	kips
$P/2$	=	16.00	kips

$W$	=	12.00	ft
$S$	=	3.00	ft
$x_1$	=	0.67	ft
$x_2$	=	5.33	ft

Reactions

$R_A$	=	6.393	kips	$R_F$	=	-0.180	kips	$R_{TOT}$	=	$R_A + R_B + \dots + R_J$
$R_B$	=	11.633	kips	$R_G$	=	16.048	kips		=	32.0
$R_C$	=	-2.563	kips	$R_H$	=	-0.013	kips			
$R_D$	=	0.000	kips	$R_I$	=	0.003	kips			
$R_E$	=	0.680	kips	$R_J$	=	-0.001	kips			

Deadload Moment	$M_{DL}$	=	0.01	kips-ft
-----------------	----------	---	------	---------

Liveload Moment	$M_{LL}$	=	4.26	kips-ft
-----------------	----------	---	------	---------

Factored Moments :

$$M_u = 1.25M_{DL} + 1.75(1+I.M.)(M_{LL}) = 9.93 \text{ kips-ft} \quad (\text{STRENGTH I, AASHTO 3.4.1})$$

Moment Capacity :

$$\phi M_n = \phi F_y Z_x = 7.59 \text{ kips-ft}$$

where :

$\phi$	=	0.90
$F_y$	=	36.00
$Z_x$	=	1.5 (Sx)
		2.81

$$M_u > \phi M_n \quad (\text{NOT OK!!!})$$

**C. STRINGER DESIGN**

Yield Strength	$F_y$	=	36.00	ksi
Mod. of Elasticity	$E$	=	29000	ksi

*Stringer Properties: Wide Flange*

Depth	$d$	=	6.00	in
Flange Width	$b_f$	=	6.00	in
Flange thickness	$t_f$	=	0.25	in
Web thickness	$t_w$	=	0.25	in
Area	$A$	=	4.38	in <sup>2</sup>
Moment of Inertia	$I_x$	=	65.36	in <sup>4</sup>
	$I_y$	=	265.01	in <sup>4</sup>
Radius of Gyration	$r_x$	=	3.87	in
	$r_y$	=	7.78	in

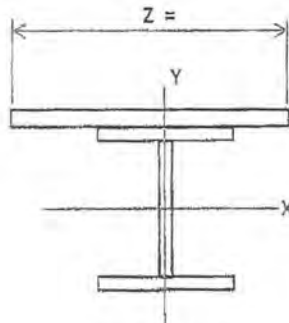

**WIDE FLANGE SECTION**

**LOADINGS**

**A. Deadload**

Deck Plate Weight	$W_1$	=	0.05	kips/ft/stringer
Stringer Weight	$W_2$	=	0.01	kips/ft/stringer
	$W_{TOT}$	=	0.08	kips/ft/stringer

**B. Liveload**

LANE LOAD:

AASHTO 3.6.1.2.4

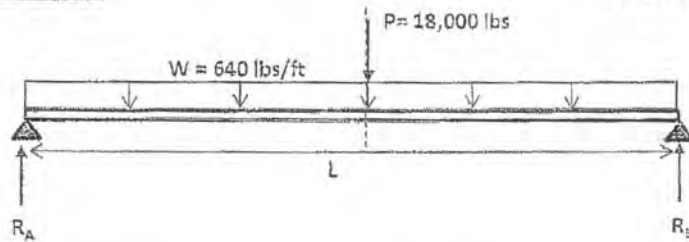

*Maximum Moment :*

Deadload Moment	$M_{DL}$	=	3.44	kips-ft
Liveload Moment	$M_{LL}$	=	114.38	kips-ft



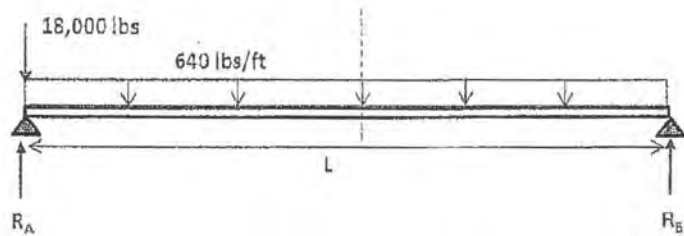

Maximum Shear :

Deadload Shear  $V_{DL} = 0.72$  kips  
 Liveload Shear  $V_{LL} = 24.08$  kips

TRUCK LOAD :

AASHTO 3.6.1.2.2

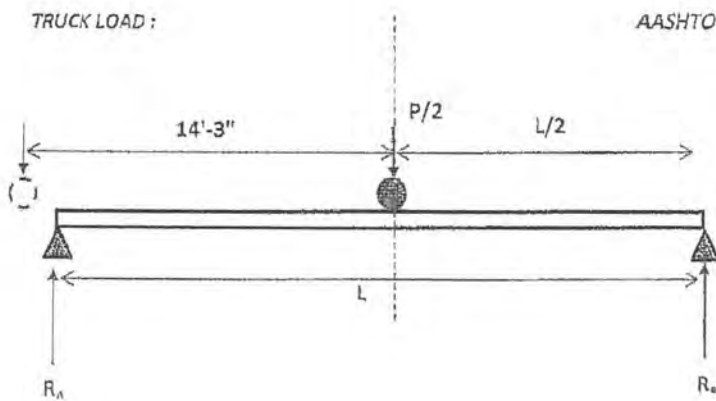

Reactions

$R_a = 8.00$  kips       $R_b = 8.00$  kips  
 $P/2 = 16.00$  kips

Maximum Moment:

Deadload Moment  $M_{DL} = 3.44$  kips-ft  
 Liveload Moment  $M_{LL} = 76.00$  kips-ft

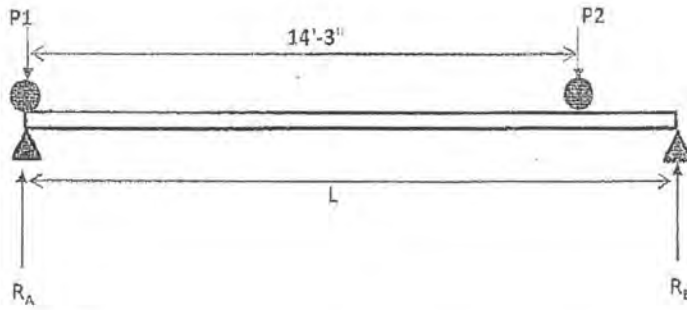

Reactions

$R_a = 20.00 \text{ kips}$        $R_b = 12.00 \text{ kips}$

Maximum Shear :

Deadload Shear       $V_{DL} = 0.72 \text{ kips}$   
 Liveload Shear       $V_{LL} = 20.00 \text{ kips}$

C. Seismic Load

AASHTO 3.10

Deck Weight	$W_d = 0.08 \text{ kip/ft}$
Stringer Weight	$W_s = 0.01 \text{ kip/ft}$
Total Dead Weight	$W_t = 0.10 \text{ kip/ft}$
Moment of Inertia	$I_x = 65.36 \text{ in}^4$
	$I_y = 265.01 \text{ in}^4$
Stringer Section Area	$A = 4.38 \text{ in}^2$
Mod. Of Elasticity	$E = 29000 \text{ ksi}$
Bridge Span	$L = 19.00 \text{ ft}$

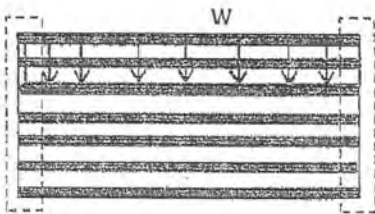

TRANSVERSE

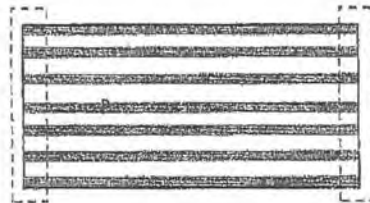

LONGITUDINAL

			TRANSVERSE	LONGITUDINAL	
Unit Deflection	$\delta$	=	$5WL^4 / 384EI$	$PL / AE$	
		=	0.0017	0.02156	ft/kip
Stiffness	$k = (1 / \delta)$	=	597.58	46.37	kip/ft
Static Displacement	$V_s = (PL / k)$	=	0.03	0.4097	ft
Single Mode Factors	$\alpha = (V_s L)$	=	0.60	7.7848	ft <sup>2</sup>
	$\beta = (\alpha Wt)$	=	0.06	0.75	ft - kip
	$\gamma = (\beta V_s)$	=	0.00185	0.30797	ft <sup>2</sup> - kip
	$T = (2\pi\gamma / P\beta\alpha)$	=	0.06	0.22	sec
Period of Oscillation	$T$	=			
Site Class	$S$	=	E		
	$F_{pga}$ (Site Class E)	=	1.08		
	$F_a$ (Site Class E)	=	0.90		
	$F_v$ (Site Class E)	=	2.40		
	$S_s$ (Guam)	=	1.50		
	$S_1$ (Guam)	=	0.60		
	PGA (Guam)	=	0.34		
	$T_M = T$	=	0.06	0.22	sec
	$A_s = F_{pga} \times PGA$	=	0.37		
	$S_{Ds} = F_a \times S_s$	=	1.35		
	$S_{D1} = F_v \times S_1$	=	1.44		
	$T_o = 0.2 \times S_1$	=	0.12		sec
	$T_s = S_{D1} / S_{Ds}$	=	1.07		sec
	$C_{SM} = A_s + (S_{Ds} / A_s) / (T_M / T_o)$	=	2.29	0.90	
	$W = Wt \times L$	=	1.83		kips
	$P_T \text{ \& } P_L = C_{SM} \times W$	=	4.20	1.66	kips

#### FACTORED MOMENTS

##### A. Strong Axis ( X - Axis )

$$M_{DL} = 3.44 \text{ kips-ft}$$

$$M_{LL} = \text{Truck + Lane Load} = 190.38 \text{ kips-ft}$$

##### B. Weak Axis ( Y - Axis )

$$M_{EQ} = P_T \times L / 4 = 19.95 \text{ kips-ft}$$

With Seismic :

$$M_{UX} = 1.25M_{DL} + 0.50(1+I.M.)(M_{LL}) \quad (\text{EXTREME EVENT I, AASHTO 3.4.1})$$

$$= 130.90 \text{ kips-ft}$$

$$M_{UY} = 1.0 M_{EQ} = 19.95 \text{ kips-ft}$$

No Seismic :

$$M_{UX} = 1.25M_{DL} + 1.75(1+I.M.)(M_{LL}) \quad (\text{STRENGTH I, AASHTO 3.4.1})$$

$$= 130.90 \text{ kips-ft}$$



**FLEXURE CHECK ( BIAXIAL ) :**

**Flexural Strength**

Check Length:

$$L_b = L/4 = \boxed{4.75} \text{ ft}$$

$$L_p = 1.76 r_y (E/F_y)^{0.50} = \boxed{32.40} \text{ ft}$$

Check Compactness :

$$\lambda_f = \frac{bf}{2tf} = \boxed{2.400}$$

$$\lambda_{pf} = 0.38 \left( \frac{E}{F_y} \right)^{0.5} = \boxed{10.785}$$

Since :

$$L_b < L_p$$

$$\lambda_f < \lambda_{pf}$$

Then :

$$\phi M_{nx} = \phi F_y Z_x = \boxed{45.08} \text{ kips-ft}$$

where :

$$\phi = \boxed{0.90}$$

$$Z_x = \boxed{16.69} \text{ in}^3$$

**Section Check**

With Seismic :

$$\frac{M_{ux}}{\phi M_{nx}} + \frac{M_{uy}}{\phi M_{ny}} \leq \boxed{1.0}$$

where:

$$Z_y = \boxed{52.59} \text{ in}^3$$

$$\phi M_{ny} = \phi F_y Z_y = \boxed{141.98} \text{ kip-ft}$$

$$\frac{130.90}{45.08} + \frac{19.95}{141.98} = \boxed{3.04} \text{ (NOT OK!!!)}$$

No Seismic :

$$M_{ux} > \phi M_{nx} \text{ (NOT OK!!!)}$$

**AXIAL & FLEXURE CHECK :**

$$kL/r = \boxed{29.295}$$

$$4.71 (E/F_y)^{0.5} = \boxed{133.681}$$

$$F_e = \frac{\pi^2 E}{(kL/r)^2} = \boxed{333.51} \text{ ksi}$$

$$kL/r < 4.71 (E/F_y)^{0.5}$$

$$F_e > 0.44 F_y$$

Therefore :

$$F_{cr} = [0.658^{(F_y/F_e)}] F_y = \boxed{34.410} \text{ ksi}$$

$$P_n = F_{cr} A_g = \boxed{150.543} \text{ kips}$$

$$\left( \frac{P_L}{2\phi P_n} \right) + \left( \frac{M_{ux}}{\phi M_{nx}} \right) \leq 1.0$$

$$\left( \frac{1.66}{270.98} \right) + \left( \frac{130.90}{45.08} \right) = 2.91 \quad (\text{NOT OK!!!})$$

SHEAR CHECK :

Factored Shear

$$V_{DL} = 0.72 \text{ kips}$$

$$V_{LL} = 20.00 \text{ kips}$$

$$V_{UX} = 1.25V_{DL} + 1.75(1+I.M.)(V_{LL}) \quad (\text{STRENGTH I\_AASHTO 3.4.1})$$

$$= 14.20 \text{ kips}$$

$$\lambda_w = \frac{h}{tw} = 22.00$$

$$\lambda_1 = 2.45 \left( \frac{E}{F_y} \right)^{0.5} = 69.537 > \lambda_w$$

$$\lambda_2 = 1.37 \left( \frac{kv E}{F_y} \right)^{0.5} = 194.419 > \lambda_w \quad kv = 5.00$$

$$\lambda_3 = \text{-----} = 260 > \lambda_w$$

Shear Strength

$$\phi V_n = \phi_v A_w 0.60 F_y C_v$$

where:

$$\phi = 0.90$$

$$C_v = 1.00$$

$$\phi V_n = 29.16 \text{ kips} > V_{UX} = 14.20 \text{ kips} \quad (\text{OK!!!})$$

CASE 2:

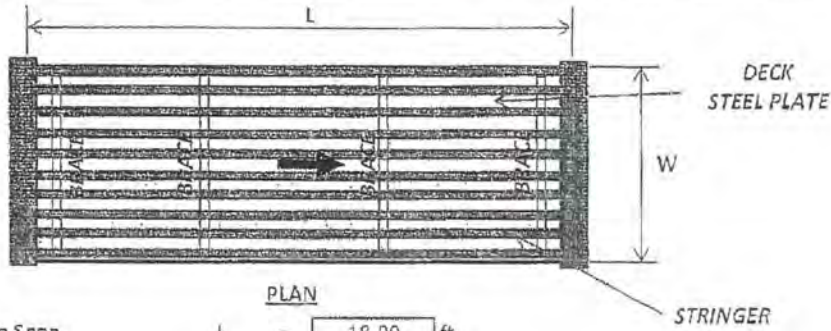

PLAN

Bridge Span	L	=	18.00	ft
Bridge Width	W	=	12.00	ft
Live Load Type		=	Special	

A. LOADINGS

Special Load	=	15.00	kips	As per Truck Specifications (Truck Weight)
	=	17.00	kips	(Lowboy Trailer Weight)
	=	74.00	kips	(Load Carried by Truck_Crane Counterweight)
$P_1$	=	15.00	kips	(Front Axle)
$P_2$	=	45.50	kips	(Rear Axle)
$P_3$	=	45.50	kips	(Rear Axle)
Axle Width	=	6.00	ft	
Wheelbase	v	=	14.00	ft

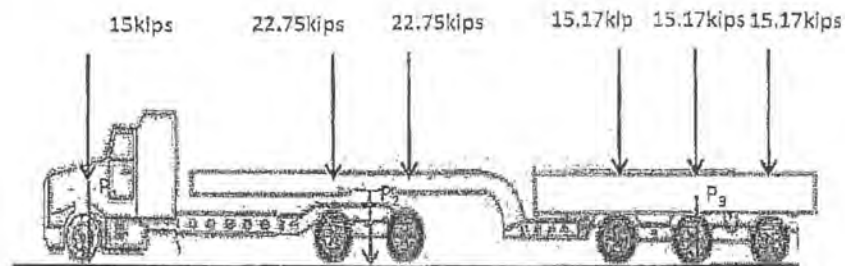



## B. DECK PLATE DESIGN

Deck Plate Properties:

Plate Thickness	t	=	0.75	in
Plate Width	v	=	20.00	in
Moment of Inertia	I	=	0.70	in <sup>4</sup>
Section Modulus	S	=	1.88	in <sup>3</sup>
Yield Strength	F <sub>y</sub>	=	36.00	ksi

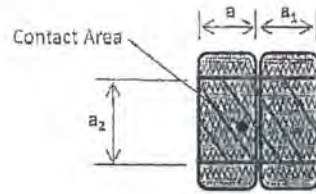

Truck Wheel

Wheel Contact Width	a <sub>1</sub>	=	10.0	in
Wheel Contact Length	a <sub>2</sub>	=	20.0	in

AASHTO 3.6.1.2.5

Dyn. Load Allowance	I.M.	=	0.33
---------------------	------	---	------

AASHTO 3.6.2

Deadload

Deck Plate Weight	w <sub>d</sub>	=	0.05	kips/ft
-------------------	----------------	---	------	---------

$$P_2/4 = 11.38 \text{ kips}$$

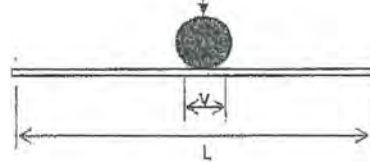

Liveload ( per Axle )

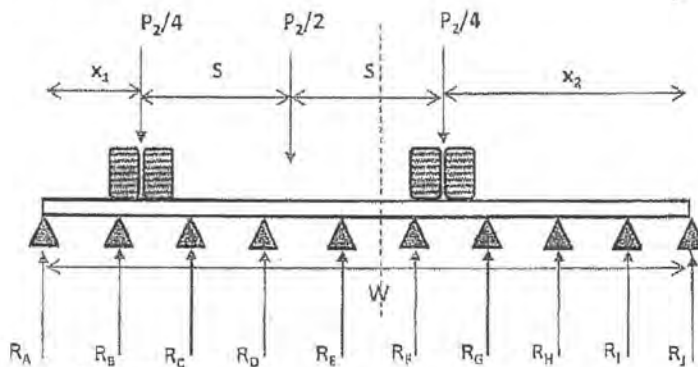

P <sub>1</sub>	=	45.50	kips
P <sub>2</sub> /4	=	11.38	kips

W	=	12.00	ft
S	=	3.00	ft
x <sub>1</sub>	=	0.67	ft
x <sub>2</sub>	=	5.33	ft

Reactions

R <sub>A</sub>	=	4.547	kips	R <sub>F</sub>	=	-0.128	kips	R <sub>TOT</sub>	=	R <sub>A</sub> + R <sub>B</sub> + ... + R <sub>J</sub>
R <sub>B</sub>	=	8.274	kips	R <sub>G</sub>	=	11.414	kips		=	22.8
R <sub>C</sub>	=	-1.823	kips	R <sub>H</sub>	=	-0.009	kips			
R <sub>D</sub>	=	0.000	kips	R <sub>I</sub>	=	0.002	kips			
R <sub>E</sub>	=	0.483	kips	R <sub>J</sub>	=	-0.001	kips			

Deadload Moment	M <sub>DL</sub>	=	0.01	kips-ft
-----------------	-----------------	---	------	---------

Liveload Moment	M <sub>LL</sub>	=	3.03	kips-ft
-----------------	-----------------	---	------	---------

Factored Moments :

$$M_U = 1.25M_{DL} + 1.75(1 + I.M.)(M_{LL}) = 7.07 \text{ kips-ft} \quad (\text{STRENGTH I, AASHTO 3.4.1})$$

Moment Capacity :

$$\phi M_n = \phi F_y Z_x = 7.59 \text{ kips-ft}$$

where :

$\phi$	=	0.90	
F <sub>y</sub>	=	36.00	ksi
Z <sub>x</sub>	=	1.5 (S <sub>x</sub> )	
	=	2.81	in <sup>3</sup>

$$M_u < \phi M_n \quad (\text{OK!!!})$$

**C. STRINGER DESIGN**

Yield Strength  $P_y = 36.00$  ksi  
 Mod of Elasticity  $E = 29000$  ksi

*Stringer Properties: Wide Flange*

Depth	$d = 6.00$	in
Flange Width	$b_f = 6.00$	in
Flange thickness	$t_f = 0.25$	in
Web thickness	$t_w = 0.25$	in
Area	$A = 4.38$	in <sup>2</sup>
Moment of Inertia	$I_x = 65.36$	in <sup>4</sup>
	$I_y = 265.01$	in <sup>4</sup>
Radius of Gyration	$r_x = 3.87$	in
	$r_y = 7.78$	in

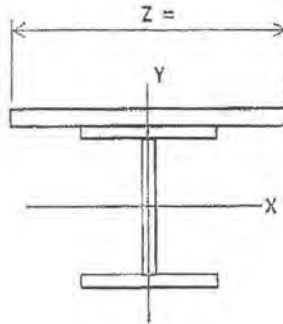

**LOADINGS**

**A. Deadload**

Deck Plate Weight	$w_1 = 0.06$	kips/ft/stringer
Stringer Weight	$w_2 = 0.01$	kips/ft/stringer
$w_{TOT}$	$= 0.08$	kips/ft/stringer

**B. Liveload**

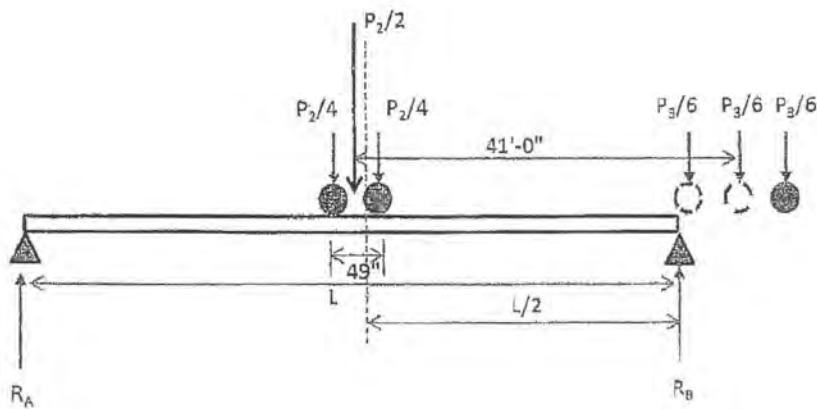

**Reactions**

$R_a = 12.67$	kips	$P_1 = 15.00$	kips
$R_b = 10.08$	kips	$P_2 = 45.50$	kips
		$P_3 = 45.50$	kips

**Maximum Moment:**

Deadload Moment	$M_{DL} = 3.08$	kips-ft
Liveload Moment	$M_{LL} = 75.20$	kips-ft

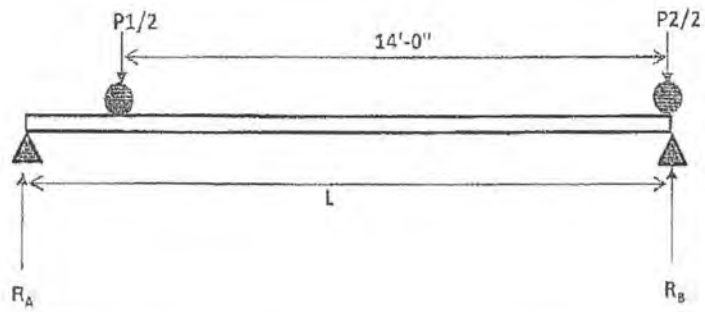

Reactions

$R_a = 5.83 \text{ kips}$        $R_b = 24.42 \text{ kips}$

Maximum Shear :

Deadload Shear       $V_{DL} = 0.69 \text{ kips}$   
 Liveload Shear       $V_{LL} = 24.42 \text{ kips}$

C. Seismic Load

AASHTO 3.10

Deck Weight	$W_d = 0.08 \text{ kip/ft}$
Stringer Weight	$W_s = 0.01 \text{ kip/ft}$
Total Dead Weight	$W_t = 0.10 \text{ kip/ft}$
Moment of Inertia	$I_x = 65.36 \text{ in}^4 \text{ (Strong Axis)}$
	$I_y = 265.01 \text{ in}^4 \text{ (Weak Axis)}$
Stringer Section Area	$A = 4.38 \text{ in}^2$
Mod. Of Elasticity	$E = 29000 \text{ ksi}$
Bridge Span	$L = 18.00 \text{ ft}$

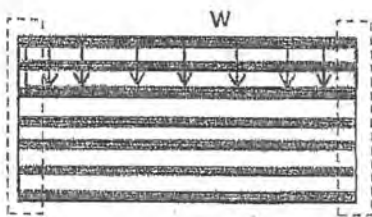

TRANSVERSE

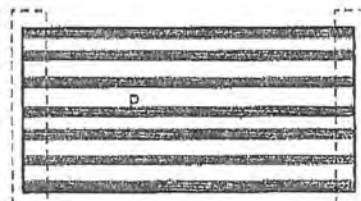

LONGITUDINAL



			TRANSVERSE	LONGITUDINAL	
Unit Deflection	$\delta$	=	$5WL^3 / 384EI$	$PL / AE$	
		=	0.0014	0.02043	ft/kip
Stiffness	$k = (1 / \delta)$	=	702.81	48.95	kip/ft
Static Displacement	$V_s = (PL / k)$	=	0.03	0.3677	ft
Single Mode Factors	$\alpha = (V_s L)$	=	0.46	6.6192	ft <sup>2</sup>
	$\beta = (\alpha Wt)$	=	0.04	0.64	ft - kip
	$\gamma = (\beta V_s)$	=	0.00114	0.23502	ft <sup>2</sup> - kip
Period of Oscillation	$T = (2\pi\gamma / P\gamma\alpha)$	=	0.06	0.21	sec
Site Class	S	=	E		
	$F_{pga}$ (Site Class E)	=	1.08		
	$F_a$ (Site Class E)	=	0.90		
	$F_v$ (Site Class E)	=	2.40		
	$S_s$ (Guam)	=	1.50		
	$S_1$ (Guam)	=	0.60		
	PGA (Guam)	=	0.34		
	$T_M = T$	=	0.06	0.21	sec
	$A_s = F_{pga} \times PGA$	=	0.37		
	$S_{DS} = F_a \times S_s$	=	1.35		
	$S_{D1} = F_v \times S_1$	=	1.44		
	$T_o = 0.2 \times S_1$	=	0.12		sec
	$T_s = S_{D1} / S_{DS}$	=	1.07		sec
	$C_{SM} = A_s + (S_{DS} / A_s) / (T_M / T_o)$	=	2.51	0.93	
	$W = Wt \times L$	=	1.74		klps
	$P_T \& P_L = C_{SM} \times W$	=	4.36	1.62	klps

#### FACTORED MOMENTS

##### A. Strong Axis (X - Axis)

$$M_{DL} = 3.08 \text{ klps-ft}$$

$$M_{LL} = \text{Truck + Crane Counterweight Load} = 75.20 \text{ klps-ft}$$

##### B. Weak Axis (Y - Axis)

$$M_{EQ} = P_T \times L / 4 = 19.62 \text{ klps-ft}$$

##### With Seismic :

$$M_{UX} = 1.25M_{DL} + 0.50(1+I.M.) (M_{LL}) \quad (\text{EXTREME EVENT I\_AASHTO 3.4.1})$$

$$= 53.86 \text{ klps-ft}$$

$$M_{UY} = 1.0 M_{EQ}$$

$$= 19.62 \text{ klps-ft}$$

##### No Seismic :

$$M_{UX} = 1.25M_{DL} + 1.75(1+I.M.) (M_{LL}) \quad (\text{STRENGTH I\_AASHTO 3.4.1})$$

$$= 53.86 \text{ klps-ft}$$

FLEXURE CHECK ( BIAXIAL ) :

Flexural Strength

Check Length:

$$L_b = \frac{L}{4} = \boxed{4.50} \text{ ft}$$

$$L_p = 1.76 r_y (E/F_y)^{0.30} = \boxed{32.40} \text{ ft}$$

Check Compactness:

$$\lambda_f = \frac{bf}{2tf} = \boxed{2.400}$$

$$\lambda_{pf} = 0.38 \left( \frac{E}{F_y} \right)^{0.5} = \boxed{10.785}$$

Since:

$$L_b < L_p$$

$$\lambda_f < \lambda_{pf}$$

Then:

$$\phi M_{nx} = \phi F_y Z_x = \boxed{45.08} \text{ kips-ft}$$

where:

$$\phi = \boxed{0.90}$$

$$Z_x = \boxed{16.69} \text{ in}^3$$

Section Check

With Seismic:

$$\frac{M_{ux}}{\phi M_{nx}} + \frac{M_{uy}}{\phi M_{ny}} \leq \boxed{1.0}$$

where:

$$Z_y = \boxed{52.59} \text{ in}^3$$

$$\phi M_{ny} = \phi F_y Z_y = \boxed{141.98} \text{ kip-ft}$$

$$\frac{53.86}{45.08} + \frac{19.62}{141.98} = \boxed{1.33} \text{ (NOT OK!!!)}$$

No Seismic:

$$M_{ux} > \phi M_{nx} \text{ (NOT OK!!!)}$$

AXIAL & FLEXURE CHECK :

$$kL/r = \boxed{27.753}$$

$$4.71 (E/F_y)^{0.5} = \boxed{133.681}$$

$$F_e = \frac{\pi^2 E}{(kL/r)^2} = \boxed{371.59} \text{ ksf}$$

$$kL/r < 4.71 (E/F_y)^{0.5}$$

$$F_e > 0.44 F_y$$

Therefore:

$$F_{cr} = [0.658^{(F_y/F_e)}] F_y = \boxed{34.569} \text{ ksf}$$

$$P_n = F_{cr} A_g = \boxed{151.241} \text{ kips}$$

$$\left( \frac{P_L}{2\phi P_n} \right) + \left( \frac{M_{ux}}{\phi M_{nx}} \right) \leq 1.0$$

$$\left( \frac{1.62}{272.23} \right) + \left( \frac{53.86}{45.08} \right) = 1.20 \quad (\text{NOT OK!!!})$$

**SHEAR CHECK :**

**Factored Shear**

$$V_{DL} = 0.69 \text{ kips}$$

$$V_{LL} = 24.42 \text{ kips}$$

$$V_{UX} = 1.25V_{DL} + 1.75(1+I.M.)(V_{LL}) \quad (\text{STRENGTH I\_AASHTO 3.4.1})$$

$$= 17.09 \text{ kips}$$

$$\lambda_w = \frac{h}{t_w} = 22.00$$

$$\lambda_1 = 2.45 \left( \frac{E}{F_y} \right)^{0.5} = 69.537 > \lambda_w$$

$$\lambda_2 = 1.37 \left( \frac{k_v E}{F_y} \right)^{0.5} = 194.419 > \lambda_w \quad k_v = 5.00$$

$$\lambda_3 = \text{-----} = 260 > \lambda_w$$

**Shear Strength**

$$\phi V_n = \phi_v A_w 0.60 F_y C_v$$

where:

$$\phi = 0.90$$

$$C_v = 1.00$$

$$\phi V_n = 29.16 \text{ kips} > V_{UX} = 17.09 \text{ kips} \quad (\text{OK!!!})$$





## WEEKLY STATUS REPORT

<b>Report No.:</b>	<b>For Week Ending: 07/18/15</b>	<b>Project No.: W11-007-BND</b>	
Edward Meno		Richard Senecal	
<b>Signature</b>	<b>Date:</b>	<b>CM Review</b>	<b>Date:</b>

**Job Name:** GWA System Wide District Meters

**Location:** Various locations around island.

**Weather:** Mostly cloudy with scattered showers for the week.

**General:**

**Pre-Cast Yard:**

- Begin preparations for the upcoming outage on 7/16/15 at Site 11, Meter #3 and #5. Transition connection fittings, flanged pipe, gate valves, tee, angle fittings for each meter was assembled, precut and inventoried for transport to site 11.
- Transfer piping, fittings, valves and assemblies to Site 11.

**Site #2:**

- Excavator mobilized, standing by for exploratory excavation.
- Install slit fence and adjust concrete barriers.
- Start exploratory excavation for new meter position.

**Site #11:**

- Pre outage schedule and procedure meeting with GWA, contractor/ subcontractor and CMStanley Consultants.
- Meters #1, #2 hydrostatic tests conducted and passed the second attempt.
- Meter #3 and #5, Preparations on site continued for the connection outage.
- Clearing around the existing pipes at all meters for the transition "TEE" connections.
- Pouring of the meter supports at all meters on Site 11.
- Meters #1 and #2 chlorine injected and flushed out and refilled for bacterial test. Passed
- Meter #3 and #5 Outage for transition and connection to GWA waterlines. Water outage Completed.

**Site #12:**

- No activity

**Site #13:**

- No activity

**Site #3:**

- Access and confirm site plan details to the present site topographical conditions and slope of embankment at proposed meter site. Confirm plan utility locations to actual on site.



# EXHIBIT D

# **EXHIBIT D**

Termination Letter dated July 10, 2015  
to Mr. Byong Ho Kim from Glenn Leon Guerrero  
Re: Bile/Pigua Bridge Replacement  
Project No. GU-NH-NBIS(007)





The Honorable  
Eddie Baza Calvo  
Governor

The Honorable  
Ray Tenorio  
Lieutenant Governor

COPY



public works  
DIPARTAMENTON CHE'CHO PUPPLEKO  
Glenn Leon Guerrero  
Director  
Felix C. Benavente  
Deputy Director

July 10, 2015

**VIA HAND DELIVERY AND CERTIFIED MAIL**

Mr. Byong Ho Kim  
President  
Korando Corporation  
P.O. Box 20538  
GMF, GU 96921

RECEIVED  
DATE: 7/10/15

*Korando Corporation*  
*Felix C. Benavente*

Re: **BILE/PIGUA BRIDGE REPLACEMENT**  
**Project No. GU-NH-NBIS(007)**  
Surety: Westchester Fire Insurance Company  
Bond No.: K07901689  
Amount of Bond: \$3,665,559.00

Mr. Kim:

It is the finding of the Government of Guam that Korando Corporation ("Korando") has breached its contractual obligations with respect to the Bile/Pigua Bridge Replacement Contract dated June 10, 2014, by performing those obligations negligently and in failing to timely prosecute the construction work. This includes, but is not limited to, evidence of the following:

1. **Section 108.1 – Commencement, Prosecution and Completion of Work** obligates contractor to "(a) commence work under this contract immediately after the issuance of the **Notice to Proceed**, prosecute the work diligently, ...
2. **Section 108.5 (e)** If the Contractor shall refuse or fail to prosecute the work or any part thereof with such diligence as will insure its completion within the period herein specified ...
3. **Section 108.5 (f)** If the Contractor shall refuse or fail to regard the laws, ordinances or instructions of the Contracting Officer or otherwise be guilty of substantial violations of any provision of the contract, then, in any such event, the Owner, upon receipt of certification from the Contracting Officer justifying that sufficient cause exists, may within 10 calendar days terminate the employment of that Contractor, ...
4. **Section 155.06 – Schedule Updates**, which provides that "Failure of the contractor to maintain the construction schedules and charts will be considered justification for withholding payments.

TN15-0999



*The Honorable*  
**Eddie Baza Calvo**  
*Governor*

*The Honorable*  
**Ray Tenorio**  
*Lieutenant Governor*



**Glenn Leon Guerrero**  
*Director*  
**Felix C. Benavente**  
*Deputy Director*

July 10, 2015

**VIA HAND DELIVERY AND CERTIFIED MAIL**

Mr. Byong Ho Kim  
 President  
 Korando Corporation  
 P.O. Box 20538  
 GMF, GU 96921

**Re: BILE/PIGUA BRIDGE REPLACEMENT**  
**Project No. GU-NH-NBIS(007)**  
 Surety: Westchester Fire Insurance Company  
 Bond No.: K07901689  
 Amount of Bond: \$3,665,559.00

Mr. Kim:

It is the finding of the Government of Guam that Korando Corporation ("Korando") has breached its contractual obligations with respect to the Bile/Pigua Bridge Replacement Contract dated June 10, 2014, by performing those obligations negligently and in failing to timely prosecute the construction work. This includes, but is not limited to, evidence of the following:

1. **Section 108.1 – Commencement, Prosecution and Completion of Work** obligates contractor to "(a) commence work under this contract immediately after the issuance of the **Notice to Proceed**, prosecute the work diligently, ...
2. **Section 108.5 (e)** If the Contractor shall refuse or fail to prosecute the work or any part thereof with such diligence as will insure its completion within the period herein specified ...
3. **Section 108.5 (f)** If the Contractor shall refuse or fail to regard the laws, ordinances or instructions of the Contracting Officer or otherwise be guilty of substantial violations of any provision of the contract, then, in any such event, the Owner, upon receipt of certification from the Contracting Officer justifying that sufficient cause exists, may within 10 calendar days terminate the employment of that Contractor, ...
4. **Section 155.06 – Schedule Updates**, which provides that "Failure of the contractor to maintain the construction schedules and charts will be considered justification for withholding payments.

7/15-0999

5. **Formal Contract Article 1 (a) Contract Time.**
6. **Instructions to Bidders Article 11. Time of Completion.**
7. **Notice to Bidders Article 5. Contract Time.**
8. **FP-03 Subsection 107.01 Laws to be observed.**
9. **FP-03 Subsection 155.01 / FAR Sections 52.236-15 Schedules for Construction Contracts.**
10. **FAR and 52.249-10 Default (Fixed-Price Construction).**
11. **Article I.3 of the Required Contract Provisions (RCP) Federal-Aid Construction Contract.**
12. **Instructions to Bidders Article 25 Termination of Work on Failure to Pay Agreed Wages.**

Over the past months Korando has been counseled on these deficiencies, in particular the failure to diligently pursue the work. Despite numerous opportunities to cure, Korando continued to fail or otherwise refuse to provide adequate work force necessary to perform the work on a project that has yet to see any meaningful progress such that it is no longer possible for you to complete the work within the required contract term of 450 days. The Government finds that Korando is in material default of the Contract for the Bile/Pigua Bridge Reconstruction Project, and that it is in the best interest of the Government and residents of Guam that the Contract be immediately terminated.

Therefore, effective July 10, 2015, and pursuant to its rights under the Contract and the laws of Guam, the Government does hereby TERMINATE the same, together with Korando's right to proceed with said Contract and the work there under. The Government is notifying the surety who issued Korando's Performance and Payment Bond of this termination.

Korando is hereby ordered to peacefully surrender and leave the Project site. In addition, Korando is further ordered to protect and preserve any property in its possession in which the Government has an interest, and to transfer title and deliver to the Government, who shall take possession of and shall utilize such materials, appliances, and plants as may be on the site of the work and which are necessary to its eventual completion. This includes any completed construction and any such information, and contract rights ("Construction Materials") as Korando has specifically produced or specifically acquired for the performance of the terminated part of the Contract. DPW inspectors shall be on the premises to ensure the thorough transfer of Construction Materials and the safe removal of all Korando personnel.



Any attempt to act or perform otherwise than as ordered herein shall be construed as being intentionally hostile, and may subject Korando to criminal prosecution.

Thank you for your cooperation.

DEPARTMENT OF PUBLIC WORKS,



Glenn Leon Guerrero

*copy*  
Cc: Attorney General of Guam  
Richelle Takumi, Territorial Representative, FHWA