



Jerrick Hernandez <jhernandez@guamopa.com>

Procurement Record - OPA-PA-24-002 (PART 2)

Pia A. Castro <pacastro@portofguam.com>

Thu, Aug 22, 2024 at 10:41 AM

To: jhernandez <jhernandez@guamopa.com>

Cc: eservice <eservice@rwtguam.com>, jdwalsh <jdwalsh@rwtguam.com>, jrazzano <jrazzano@rwtguam.com>

Good morning

Attached for your information is **Part 2** of documents pertaining to **Docket No. OPA-PA-24-002**.

Thank you,

Pia

**PIA A. CASTRO**

Procurement Admin. Officer

Port of Guam, Jose D. Leon Guerrero Commercial Port

1026 Cabras Hwy., Ste. 201, PITI, GU 96915

Tel: 1-671-477-5931 Ext: 253

From: "Pia A. Castro" <pacastro@portofguam.com>**To:** "jhernandez" <jhernandez@guamopa.com>**Cc:** "eservice" <eservice@rwtguam.com>, "jdwalsh" <jdwalsh@rwtguam.com>, "jrazzano" <jrazzano@rwtguam.com>**Sent:** Thursday, August 22, 2024 10:39:47 AM**Subject:** Procurement Record - OPA-PA-24-002 (PART 1)

Good morning Jerrick,

Attached for your information is **Part 1** of documents pertaining to **Docket No. OPA-PA-24-002**.

Thank you,

Pia

**PIA A. CASTRO**

Procurement Admin. Officer

Port of Guam, Jose D. Leon Guerrero Commercial Port

1026 Cabras Hwy., Ste. 201, PITI, GU 96915

Tel: 1-671-477-5931 Ext: 253

7 attachments

 **7f PAG to Morrigo re Decision on Protest July 31 2024.pdf**

1220K

 **8a OPA-PA-24-002 Notice of Proc Appeal.pdf**

3575K

 **8b Notification of Proc Appeal to Awarded Contractor.pdf**

256K

 **9 AG Form 1 Complete Record of Proc.pdf**

53K

 **10a Emails 1 of 3.pdf**

1305K

 **10b Emails 2 of 3.pdf**

























2854K

 **10c Emails 3 of 3.pdf**

1099K

























IFB PAG 013-024 Re-Bid 180' Telescopic Boom Lift

(EMAIL PARTS 1 AND 2)

-  1a Revised Ad
-  1b Ad Block April 23 2024 - Guam Daily Post
-  2a IFB-PAG-013-24 Re-Bid 180' Telescopic Boom Lift
-  2b IFB-PAG-013-24_Part33
-  3a Morrigo Bid Submittal
-  3b Federal Contracts Corp Submittal
-  4a Bid Opening Abstract
-  4b Bid Opening Telescopic Boom Lift
-  5a NOA to FCC - Morrigo signed
-  5b NOA - Federal Contracts Corp acknowledged
-  5c Notification of Award to AGO
-  6a PO 19901-OS - June 5 2024
-  6b FCC - GSA Contract info
-  7a Morrigo Protest & FOIA June 3 2024
-  7b PAG Response to Morrigo - June 5 2024
-  7c Morrigo Supplemental Protest June 20 2024
-  7d Courier to AGO - Morrigo Bid Protest
-  7e Transmittal to AG Notice of Protest
-  7f PAG to Morrigo re Decision on Protest July 31 2024
-  8a OPA-PA-24-002 Notice of Proc Appeal
-  8b Notification of Proc Appeal to Awarded Contractor
-  9 AG Form 1 Complete Record of Proc
-  10a Emails 1 of 3
-  10b Emails 2 of 3
-  10c Emails 3 of 3

ORIGINAL BID - IFB PAG 004-024 180' Telescopic Boom Lift

(Email Part 3) Record of Planning Documents:

-  1a Procurement Planning Docs
-  1b Procurement Planning Docs
-  1c Requisition 21658 ON
-  1d Request GSA Availability
-  1e Boom lift specification
-  1f Determinations Required by Law
-  2a Ad IFB PAG 004-24 Proof_Invoice
-  2b Ad Block - Guam Post Jan26 2024
-  3a IFB PAG 004-024 180 Telescopic Boom Lift
-  3b Amendment No. 1 IFB-PAG-004-24
-  4a Far East Equipment Questions
-  4b Moricco Questions IFB-PAG-004-24
-  4c Q&C Response IFB-PAG-004-24
-  5a Bid Opening - Feb16 2024
-  5b Morricco Submittal
-  6a Notice of Rejection of Bid
-  6b Letter_ Surface Solutions IFB PAG 004 24
-  7a Procurement Protest March 5 2024
-  7b Amended Protest
-  7c Notice of Cancellation to All Registered Bidders
-  7d Determination of Rejection and Cancellation
-  7e Notice of Cancellation to AGO Transmittal
-  8a Email Communication
-  8b Email Comm - Amend 1 & Q&C distribution

7f



PORT OF GUAM
ATURIDAT I PUETTON GUAHAN
Jose D. Leon Guerrero Commercial Port
1026 Cabras Highway, Suite 201, Piti, Guam 96915
Telephone: 671-477-5931/5 | Facsimile: 671-477-2689
Website: www.portofguam.com



Lourdes A. Leon Guerrero
Governor of Guam
Joshua F. Tenorio
Lieutenant Governor

TO: Joel Lesh, Executive VP/General Manager
VIA E-MAIL AND Joel.Lesh@MorricoEquipment.com
HAND DELIVERY: 197 Ypao Road, Tamuning, GU 96913
NAME: Morrigo Equipment
DATE: July 31, 2024

RE: Decision on Protest submitted by Morrigo Equipment on June 3, 2024, and its “Supplement to Protest” submitted on June 20, 2024, for Invitation for Bids IFB-PAG-013-24, re: Procurement of 180’ Telescopic Boom Lift.

DECISION ON PROTEST

Pursuant to 2 GAR, Div. 4 § 9101(g), the Port of Guam (“Port”) hereby issues its decision on the matters raised in a letter labeled “Bid Protest” (“Protest”) hand delivered by Morrigo Equipment (“Morrigo”) to the Port on June 3, 2024. Morrigo filed its Protest after receiving written notice that Federal Contracts Corporation (“FCC”) was determined to be the winning vendor for IFB-PAG-013-24, dated May 20, 2024. *Notice of Award for Invitation for Bid IFB-PAG-013-24 for 180’ Telescopic Boom Lift* (May 20, 2024). The Port hereby denies the Protest.

MORRICO PROTEST AND SUPPLEMENTAL PROTEST COMPLAINTS

1. The FCC is a non-responsive and/or non-responsible bidder because it did not submit “the bid security necessary for a responsive bid” and it “failed to execute and provide the Bid Bond form” therefore, the award issued to FCC “constituted a mistake....” *Morrigo Protest*, p. 1, Bid Protest, ¶ 2 (June 3, 2024); *Morrigo Supplemental Bid Protest*, p. 1, ¶ 2 (June 20, 2024).
2. The FCC is a non-responsive and/or non-responsible bidder because it “fails to have the necessary business and other licenses needed to make sales to the Port” and therefore, the award issued to FCC “constituted a mistake....” *Morrigo Protest*, p. 1, Bid Protest, ¶ 2 (June 3, 2024).
3. The FCC is a non-responsive and/or non-responsible bidder because its submitted bid form did not check the “Yes, offer as requested” check boxes on the bid form for several optional bid items listed on pp. 32-33 of the IFB solicitation document, and therefore, “an award cannot be made to FCC.” *Morrigo Supplemental Bid Protest*, p. 2, Relief Requested (June 20, 2024).
4. Morrigo’s Supplemental Protest complains that “[o]n June 5, 2024, PAG declined to comply with the [June 3, 2024] Sunshine Act Request, and instead invited Morrigo to proceed to PAG to review the records there. Our team eventually did review the records, and that review has necessitated this protest supplement.” *Morrigo Supplemental Bid Protest*, p. 1, ¶ 1 (June 20, 2024).

Decision on Protest

Date: July 31, 2024

Subject: Decision on Protest of June 3, 2024, and “Supplement to Protest” of June 20, 2024, submitted by Morrico Equipment for Invitation for Bids IFB-PAG-013-24, re: Procurement of 180’ Telescopic Boom Lift.

Page 2 of 21

MORRICO PROTEST REQUESTED REMEDIES

1. With respect to Morrico’s first complaint, Morrico requests that FCC’s winning submission be rejected, and the award to FCC rescinded, so that Morrico “should be made the awardee of the IFB.” *Morrigo Protest*, p. 1, Relief Requested (June 3, 2024); *Morrigo Supplemental Bid Protest*, p. 2, Relief Requested (June 20, 2024).
2. With respect to Morrico’s second complaint, Morrico requests that FCC’s winning submission be rejected, and the award to FCC rescinded, so that Morrico “should be made the awardee of the IFB.” *Morrigo Protest*, p. 1, Relief Requested (June 3, 2024).
3. With respect to Morrico’s third complaint, Morrico requests that FCC’s winning submission be rejected, and the award to FCC rescinded, so that Morrico “should be made the awardee of the IFB.” *Morrigo Supplemental Bid Protest*, p. 2, Relief Requested (June 20, 2024).
4. With respect to Morrico’s fourth complaint, Morrico makes no request for relief. Morrico requests no remedy under Guam’s Procurement Law, Guam’s Procurement Rules and Regulations, or the Sunshine Reform Act. *See* 5 GCA §§ 5451, 5452; 2 GAR, Div. 4 §§ 9104, 9105, and 9106; and 5 GCA §§ 10111, and 10112.

STATEMENT OF FINDINGS:

The Port makes the following findings:

I. *Substantive Content of First, Second, and Third Protest and Supplemental Protest Complaints:*

Morrigo complains that FCC was not required to submit a bid bond and a completed bid bond form as security to the government of Guam and/or the Port to secure its bid for this procurement, which resulted in a “*de facto* unfair pricing advantage ...” *Morrigo Supplemental Bid Protest*, p. 2, Relief Requested (June 20, 2024). Morrico further complains that FCC did not present Guam business licenses in its priced submission, rendering FCC non-responsive and/or non-responsible. Finally, on these bases, Morrico requests rejection of FCC’s price quote, rescission of the May 20, 2024 Notice of Award, and award of a contract to itself. *Id.*

In order to constitute a valid protest, the protest must raise complaints regarding the “method of source selection, solicitation or award of a contract, ...” 5 GCA § 5425(a). These objections in the Protest and Supplemental Protest do not raise complaints about the method of source selection used (*i.e.*, use of the Invitation for Bids process), nor do they raise complaints about the solicitation document that was issued or any of its terms or conditions. Morrico makes no complaint concerning the language or content of the IFB or any other part of the solicitation process. The

Decision on Protest

Date: July 31, 2024

Subject: Decision on Protest of June 3, 2024, and “Supplement to Protest” of June 20, 2024, submitted by Morrico Equipment for Invitation for Bids IFB-PAG-013-24, re: Procurement of 180’ Telescopic Boom Lift.

Page 3 of 21

Protest documents unambiguously state that Morrico is aggrieved by the written announcement of FCC as the lowest responsible, responsive vendor in response to IFB-PAG-013-24 (“IFB”), after notice of an award of a contract to FCC, which Morrico received on May 20, 2024. *Morrigo Protest*, p. 1, Section II; see 5 GCA Section 5211(g) (“Award. The contract shall be awarded with reasonable promptness by written notice...”); and *Notice of Award* (May 20, 2024). The factual bases of these complaints solely raise allegations of defects in FCC’s bid submission and the selection of FCC for award. Therefore, it is clear that Morrico protests the Port’s the award of the contract to FCC, and no other part of the procurement process for this IFB.

II. *Unfounded Claims of a “Stay” of Procurement:*

Morrigo attempts to “stay” the procurement process in this matter by stating “[w]e understand this to be a pre-award procurement protest of IFB-PAG-013-24,” in order to trigger the provisions of 5 GCA § 5425 and 2 GAR, Div. 4, § 9101(g), and thereby halt the procurement. *Morrigo Protest*, p. 1, Automatic Stay. Neither this statute nor this rule require a stay in this case. 2 GAR, Div. 4 § 9101(e) states: “[w]hen a protest has been filed within 14 days and before an award has been made, ... the head of a Purchasing Agency shall make no award of the contract prior to final resolution of such protest” *Id.* (emphases added). Likewise, 5 GCA § 5425(g) prevents the government from proceeding “with the award of the contract prior to final resolution of such protest” *Id.* (emphases added).

In order to stop the contract awarding process, a protestor must file its protest prior to the award. 2020 Guam 20, ¶ 148 (citing *Teleguam Holdings, LLC v. Guam*, 2015 Guam 13 ¶ 35 [hereinafter “*Teleguam Holdings I*”] and *Guam Imaging Consultants, Inc. v. Guam Mem’l Hosp. Auth.*, 2004 Guam 15 ¶ 24). A contract was already awarded in this matter on May 20, 2024, well before Morrico lodged its protest on June 3, 2024.

Without citation to fact or law, Morrico’s Protest and Supplemental Protest attempt to characterize its protest as “pre-award,” despite having received the clearly labeled “Notice of Award” for Invitation for Bid IFB-PAG-013-24. *Morrigo Protest*, p. 1, Automatic Stay. Morrico’s claim is unfounded in fact or law. “How a protest is framed by the aggrieved bidder—including whether they frame the protest as a challenge to the solicitation, the evaluation, or the award—does not dictate when the time period to file a protest begins to run.” *DFS v. GIAA*, 2020 Guam 20 ¶ 86 (footnote omitted).

The “Notice of Award” in this matter consists of the written notice issued to FCC as the winning vendor after the Port “evaluated the bids received” *Notice of Award*, IFB-PAG-013-24 (issued to Morrico and FCC). The Notice of Award sent to both Morrico and FCC clearly and unambiguously states that “the Port Authority of Guam is hereby announcing its award to the following bidder: Federal Contracts Corp.” *Notice of Award*, IFB-PAG-013-24 (emphasis added).

Decision on Protest

Date: July 31, 2024

Subject: Decision on Protest of June 3, 2024, and “Supplement to Protest” of June 20, 2024, submitted by Morrico Equipment for Invitation for Bids IFB-PAG-013-24, re: Procurement of 180’ Telescopic Boom Lift.

Page 4 of 21

This May 20, 2024 notice announcing the award was issued to both FCC and Morrico after evaluations were completed and FCC was found to be the lowest responsible and responsive vendor, in order to make the award to FCC known to all bidders and the public. 2 GAR, Div. 4 § 3109(q): “Publicizing Awards. Written notice of award shall be sent to the successful bidder. In procurement over \$25,000, each unsuccessful bidder shall be notified of the award. Notice of award shall be made available to the public.” *Id*; see also 5 GCA § 5211(g) ((Competitive Sealed Bidding, Award) “Award. *The contract shall be awarded with reasonable promptness by written notice to the lowest responsible bidder....*”) (emphases added). The contract was awarded, documented, and made known to everyone, including the successful vendor (FCC) and the unsuccessful vendor (Morrico), through this Notice of Award issued on May 20, 2024. Morrico waited until after this notice was issued and the bid status was provided to file its Protest. *Morrigo Protest*, p. 1, Section II.

Award in this matter was already made prior to the filing of the protest. Morrico’s protest documents were all filed after award. Accordingly, the provisions of 5 GCA § 5425 and 2 GAR, Div. 4 § 9101(e) allowing a protestor to prevent an agency from making “*award of the contract prior to final resolution of such protest*” could not be triggered, and Morrico’s Protest and Supplemental Protest have never operated to stay any portion of this procurement.

III. Unfounded Claims of “Declined” Sunshine Reform Act Request:

On June 3, 2024, Morrico filed its Protest, which included a records request labeled as a “Sunshine Act” request. In this request, Morrico stated: “Morrico requests ... that the Port provide to the company the complete procurement record kept for the IFB, as well as any record associated with IFB-PAG-004024(sic) and the decision to cancel that original bid process.” *Morrigo Protest*, p. 2, Sunshine Act Request (June 3, 2024).

Morrigo’s request does not specify any format or means of conveyance (electronic or otherwise) for any requested records. It simply says “provide to the company” any records. *Id*.

On June 5, 2024, the Port responded in writing to Morrico that the procurement record is always publicly available for inspection at all times during working hours, and that Guam’s Procurement Law requires public access to the record at the earliest possible time and does not require a formal written request; therefore, the record was already available for Morrico to review.

The Protest and Supplemental Protest documents filed by Morrico fail to allege any injury or violation and fail to request any cognizable remedy under Guam’s Procurement Law or Guam’s Procurement Rules and Regulations. Morrico does not allege that any person or party has violated the Sunshine Reform Act or any other relevant law, and requests no particular available relief.

Morrigo attempts to portray the Port as non-responsive, even though the Port actually responded in writing within two (2) days of Morrico’s Sunshine Reform Act request, and informed Morrico that the procurement record was available to Morrico at any time during working hours. The Port

Decision on Protest

Date: July 31, 2024

Subject: Decision on Protest of June 3, 2024, and “Supplement to Protest” of June 20, 2024, submitted by Morrico Equipment for Invitation for Bids IFB-PAG-013-24, re: Procurement of 180’ Telescopic Boom Lift.

Page 5 of 21

further informed Morrico that no formal, written record request was even needed to review the Procurement Record, because it is public at all times pursuant to Guam’s Procurement Law and Rules. Under these rules, a party may appear at an agency and request review of a procurement record without first filing a written request for records, unlike the Sunshine Reform Act.

There is no factual support for Morrico’s unfounded allegation that the Port “declined to comply” with any request to produce records under any law. The Procurement Record has been available to Morrico at all times during this procurement, even prior to award and prior to its request. Morrico could have reviewed this record at any time, and did so, after the Port provided its response. *Morrigo Supplemental Bid Protest*, p. 1, ¶ 1 (June 20, 2024).

CONCLUSIONS:

The Port hereby denies the Protest. The bases for denial are set forth under each of Morrico’s complaints as organized below:

I. FCC’s Bid Submission is Not Disqualified for Lack of Guam Bid Bond and Bid Bond Form:

Untimely: The complaints in Morrico’s Protest were untimely submitted. “Protests filed after the 14 day period shall not be considered.” 2 GAR § 9109(b)(1). All of the bid submissions were opened publicly on May 8, 2024, including FCC’s priced submission, containing its pricing, forms, and all alleged defective terms to which Morrico objects. All of these portions of FCC’s submission have been available to Morrico and the public since May 8, 2024. Guam’s Procurement Rules clearly state that:

Bids and modifications shall be opened publicly in the presence of one or more witnesses, at the time, date, and place designated in the Invitation for Bids. The name of each bidder, the bid price, and such other information as is deemed appropriate by the Procurement Officer, shall be read aloud or otherwise made available..... The opened bids shall be available for public inspection

2 GAR, Div. 4 § 3109(1)(2).

FCC’s bid submission was publicly opened, its price quote was announced, and the full contents of its offer, including all documents submitted, were available to Morrico on May 8, 2024.

Therefore, May 8, 2024 is the date that Morrico was on notice that FCC’s submission included all of the allegedly defective terms of which Morrico complains in the Protest(s). These documents and terms have not changed, and did not change upon the issuance of a Notice of Award. All of Morrico’s claims are based on allegations that FCC’s submission was “non-responsive” and that FCC is “non-responsible” based on items and documents that are alleged to be missing from FCC’s

Decision on Protest

Date: July 31, 2024

Subject: Decision on Protest of June 3, 2024, and “Supplement to Protest” of June 20, 2024, submitted by Morrico Equipment for Invitation for Bids IFB-PAG-013-24, re: Procurement of 180’ Telescopic Boom Lift.

Page 6 of 21

bid submission. All of the facts concerning FCC’s bid upon which Morrico bases its Protest and Supplemental Protest were public and actually known to Morrico as of May 8, 2024. Yet, Morrico did not complain of these facts until after the Notice of Award was issued on May 20, 2024, announcing FCC as the “lowest, responsible, and responsive bid offer” with whom a finalized contract would be entered. *Morrigo Protest*, p. 1, Section II.

Morrigo waited to file its Protest (and its request for records) until June 3, 2024, after a winning vendor was announced by written notice to all vendors who submitted a bid. *Notice of Award*, IFB-PAG-013-24. It further waited another 17 days to file its Supplemental Bid Protest on June 20, 2024. Both the Protest and the Supplemental Protest contain only allegations that FCC’s bid should be rejected as non-responsive and non-responsible due to the contents of its submission. There are no allegations concerning the IFB solicitation document or other aspects of the procurement process. The Protest(s) were submitted well beyond the 14-day time period of when Morrico first knew or should have known of the facts giving rise to its complaints. 5 GCA § 5425(a) and 2 GAR, Div. 4 § 9101(c)(1); *DFS Guam, L.P. v. The A.B. Won Pat International Airport Authority, Guam*, 2020 Guam 20, ¶ 95-96; *see also In the Appeal of ASC Trust Corporation*, OPA-PA-09-010 (finding that the fourteen-day clock begins when a party should first be aware of facts giving rise to the protest). Accordingly, Morrico’s complaints in its Protest and Supplemental Protest are untimely.

Morrigo is not entitled to any relief because its Protest(s) are not timely. It is not entitled to have any of its complaints considered on the merits. However, in order to establish a full record for posterity, the Port will further address the substance of Morrico’s arguments.

This Complaint Has No Merit: Morrico complains that FCC is a non-responsive and/or non-responsible bidder because it did not submit “the bid security necessary for a responsive bid” and it “failed to execute and provide the Bid Bond form” *Morrigo Protest*, p. 1, ¶2; *Morrigo Supplemental Protest*, p. 1, ¶ 2.

However, Morrico simply ignores the fact that, with respect to competitive solicitations by recipients using federal funds, federal law applies. 2 CFR § 200.101. More importantly, federal law controls. Whenever the government of Guam is conducting a procurement using federal funds, if Guam’s Procurement Law and federal procurement laws or requirements conflict, federal law overrides Guam law. 5 GCA § 5501 (“Federal Funds. Where a procurement involves the expenditure of federal assistance or contract funds, or other federal funds ... all persons within the government of Guam shall comply with such federal law and regulations which are applicable and which may be in conflict with or may not be reflected in this Chapter.”) and 5004(b) (“Nothing in this Chapter or in regulations promulgated hereunder shall prevent any governmental body ... from complying with the terms and conditions of any grant....”).

Decision on Protest

Date: July 31, 2024

Subject: Decision on Protest of June 3, 2024, and “Supplement to Protest” of June 20, 2024, submitted by Morrico Equipment for Invitation for Bids IFB-PAG-013-24, re: Procurement of 180’ Telescopic Boom Lift.

Page 7 of 21

Federal Law Controls this Procurement

This procurement is funded with federal funds from the U.S. Maritime Administration (MARAD) FY2022 American Marine Highway (AMH) Grant No.: 693JF72340007.

FCC is a contractor who has been awarded a contract by the Federal General Services Agency (Fed GSA), under GSA Contract #GS-03F-113DA, as a competitively selected vendor whose contract is publicly listed on the Multiple Award Schedule (MAS), also known as the Federal Supply Schedule, to provide supplies to qualifying governments and non-federal entities (NFE’s), pursuant to federal law.

The MAS is a long-term government-wide contract with commercial firms providing eligible buyers access to commercial products and services at volume discount pricing. FAR §§ 8.401(a) and 38.101(a). Eligible NFE’s that include state, tribal, and local governments, as well as some educational institutions, are permitted by law to procure goods and services from the Federal Supply Schedule/MAS. The government of Guam and its agencies (including the Port) are specifically authorized by federal law to use the Federal Supply Schedule/MAS. 48 U.S.C. § 1469e and 40 U.S.C. § 502(c)(2). “The Governments of the Commonwealth of Puerto Rico, Guam, American Samoa, the Commonwealth of the Northern Mariana Islands, and the United States Virgin Islands are authorized to make purchases through the General Services Administration.” 48 U.S.C. 1469e (Pub. L. 102–247, title III, §302, Feb. 24, 1992, 106 Stat. 38; Pub. L. 114–187, title IV, §406, June 30, 2016, 130 Stat. 592).

Under these laws, Fed GSA offers multiple efficient and effective procurement programs for state, tribal, and local governments to purchase products and services directly from the pre-vetted and competitively selected contractors listed in the Federal Supply Schedule, at a bulk discount. FAR §§ 8.402(c)(2), 38.101(e); GSAR §§ 538.270, .271, and .273.

These contractors: 1) have already been certified as responsible by Fed GSA; 2) have already entered into a Fixed Price with Economic Price Adjustment (EPA) Indefinite Delivery Indefinite Quantity (IDIQ) contract resulting from a competitive open solicitation; and 3) are already bound by the contractual terms of the MAS. *Ids*, FAR §§ 8.401(a), 8.404(d), and 52.216-1; GSA Contract #GS-03F-113DA; and Multiple Award Schedule Solicitation Document Solicitation Number: 47QSMD20R0001.

Because these contractors have already competed in an open competitive solicitation and were selected for award of an MAS contract:

Orders placed against a Multiple Award Schedule (MAS), using the procedures in this subpart, are considered to be issued using full and open competition (see 6.102(d)(3)). (i) Ordering offices need not seek further competition, synopses the requirement, make a separate determination of fair and reasonable pricing, or

Decision on Protest

Date: July 31, 2024

Subject: Decision on Protest of June 3, 2024, and “Supplement to Protest” of June 20, 2024, submitted by Morrico Equipment for Invitation for Bids IFB-PAG-013-24, re: Procurement of 180’ Telescopic Boom Lift.

Page 8 of 21

consider small business programs. (ii) GSA has already determined the prices of items under schedule contracts to be fair and reasonable.

FAR § 8.404(a)(1)(emphases added).

By law, eligible NFE’s satisfy the federal requirements for full and open competition when they purchase from a Fed GSA schedule, and the Fed GSA ordering procedures are followed. Federal Acquisition Regulations (FAR) § 6.100 (“This subpart prescribes the policy and procedures that are to be used to promote and provide for full and open competition.”); and FAR § 6.102 (“Use of competitive procedures. The competitive procedures available for use in fulfilling the requirement for full and open competition are as follows: ... (d)(3) Use of multiple award schedules issued under the procedures established by the Administrator of General Services consistent with the requirement of 41 U.S.C.152(3)(A) for the multiple award schedule program of the General Services Administration is a competitive procedure.”) (emphasis added).

Pursuant to 2 CFR 200, states are NFE’s when making procured purchases using federal funds. 2 CFR § 200.1, *Non-Federal Entity (NFE)*. If a state, which includes state and territorial agencies and instrumentalities, and includes the government of Guam and its agencies (*i.e.*, the Port), 2 CFR § 200.1 *state*, procures goods or services using the Federal Supply Schedule/MAS, the state must take steps to comply with its own procurement policies and rules, pursuant to 2 CFR § 200.317 through 2 CFR § 200.327, to the extent that those procurement rules and procedures do not conflict with federal mandates applicable to the funding source, 2 CFR 200, and any other applicable federal purchasing procedures. 2 CFR § 200.320 (“The non-Federal entity must have and use documented procurement procedures, consistent with the standards of this section and §§ 200.317, 200.318, and 200.319”). NFE’s may not change the terms and conditions of any MAS contract, except to add any required clauses that do not contravene the original terms. GSAR §§ 552.238-114(e), 538.7003(d); and 552.104(a).

Thus, when federal funds are involved, NFE’s follow both the contract requirements of the MAS at GSAR Part 552 and the contracting requirements at 2 CFR Part 200 and Appendix II, plus §§ 200.317 – 200.327, to include the socioeconomic affirmative steps, contractor oversight, cost and price analysis, never contracting with the enemy, and all other required contract provisions located in 2 CFR Part 200.

Both Guam law and federal law require that Guam’s local procurement processes must not conflict with federal requirements. 5 GCA §§ 5004(b) and 5501; 2 CFR §§ 200.318-320; and GSAR §§ 552.238-114(e), 538.7003(d). Thus, when procuring with federal funds, the government of Guam and the Port apply Guam’s Procurement Law and Regulations and procurement processes to the extent that those processes do not conflict with any of the other federal requirements imposed on the procurement by operation of 2 CFR 200, the MAS contract, and the federal funding source.

Decision on Protest

Date: July 31, 2024

Subject: Decision on Protest of June 3, 2024, and “Supplement to Protest” of June 20, 2024, submitted by Morrico Equipment for Invitation for Bids IFB-PAG-013-24, re: Procurement of 180’ Telescopic Boom Lift.

Page 9 of 21

Federal Law Prohibits Local Procurement Preferences and Both Guam and Federal Law Require Solicitation of Non-Local Vendors

2 CFR § 200.319(a) states: “[a]ll procurement transactions for the acquisition of property or services required under a Federal award must be conducted in a manner providing full and open competition consistent with the standards of this section and § 200.320.” *Id.*

2 CFR § 200.319(c) requires: “[t]he non-Federal entity must conduct procurements in a manner that *prohibits the use of statutorily or administratively imposed state, local, or tribal geographical preferences* in the evaluation of bids or proposals” *Id.* (emphasis added).

Under federal law, NFE’s are permitted to solicit from “pre-qualified lists” of vendors, but must “include enough qualified sources to ensure maximum open and free competition. Also, the non-Federal entity *must not preclude potential bidders from qualifying* during the solicitation period.” 2 CFR § 200.319(e) (emphasis added).

In order to comply with both of these requirements, the IFB contains the provision:

5. NO LOCAL PROCUREMENT PREFERENCE: There is no geographical preference for this IFB in compliance with 2 CFR § 200.319(c) and the terms and conditions of MARAD FY2022 American Marine Highway (AMH) Grant No.: 693JF72340007; however, no specification, term, condition, or qualification of this IFB shall exclude any Offeror from consideration on the basis of Guam-only experience, provided that the experience of such Offeror is otherwise responsive to the solicitation, in accordance with the requirements of 5 GCA § 5008.

IFB, General Terms and Conditions, p.22, ¶5.

When federal funds are involved, the government of Guam cannot artificially exclude any vendors from bidding based solely on the geographical location of the business. It cannot solicit bids or proposals only from locally-based vendors and it cannot unduly restrict competition. If there are vendors anywhere who are known to be interested in a solicitation, the government of Guam must allow the competition to be open to all such vendors. *Ids.*

The MAS is a published, publicly available, government-compiled list of vendors who are interested in providing specific supplies and services to qualified government entities, including the government of Guam. FAR §§ 8.401(a) and 38.101(a).

GSA schedule contracts require all schedule contractors to publish an ‘Authorized Federal Supply Schedule Pricelist’ (pricelist). The pricelist contains all supplies and services offered by a schedule contractor. In addition, each pricelist contains the

Decision on Protest

Date: July 31, 2024

Subject: Decision on Protest of June 3, 2024, and “Supplement to Protest” of June 20, 2024, submitted by Morrico Equipment for Invitation for Bids IFB-PAG-013-24, re: Procurement of 180’ Telescopic Boom Lift.

Page 10 of 21

pricing and the terms and conditions pertaining to each Special Item Number that is on schedule.

FAR § 8.402(b).

FCC is on this list, specifically offering the goods solicited in IFB-PAG-013-24 under GSA Contract #GS-03F-113DA, which is open until Jun 12, 2026. Therefore, the Port was required to include FCC in this open competition.

Guam’s Procurement Law contains provisions consistent with the requirement to solicit from all vendors, no matter their business location. “Publication of bids and requests for proposals shall not be manipulated so as to place potential bidders at unnecessary competitive disadvantage.” 5 GCA § 5010.

2 GAR, Div. 4, § 3109(f)(1): “Distribution. Invitations for Bids or Notices of the Availability of Invitation for Bids shall be mailed or otherwise furnished to a sufficient number of bidders for the purpose of securing competition.”

The purposes of Guam’s Procurement Law include stated policies:

(4) to ensure the fair and equitable treatment of all persons who deal with the procurement system of Guam; (5) to provide increased economy in Guam activities and to maximize to the fullest extent practicable the purchasing value of public funds of Guam; (6) to foster effective broad-based competition within the free enterprise system; ...

5 GCA § 5001(b)(4), (5), and (6).

The “free enterprise system” refers to an economy where the market determines the prices of goods and services rather than the government. *See* 22 USC § 2351, Encouragement of free enterprise and private participation (“The Congress of the United States recognizes the vital role of free enterprise in achieving rising levels of production and standards of living essential to economic progress and development.”). In order to maximize the purchasing value of the federal grant money that is funding this procurement under the free enterprise system, the solicitation must allow priced submissions from the full market of available vendors.

In accordance with these mandates, the IFB also contained specific notice that the pricing of contractors listed on the Federal Supply Schedules would be accepted in response to this solicitation:

48. FEDERAL GSA SCHEDULES: This IFB is federally funded under MARAD FY2022 American Marine Highway (AMH) Grant No.: 693JF72340007; The Port Authority of Guam is accepting Federal GSA pricing inclusive with shipping cost

Decision on Protest

Date: July 31, 2024

Subject: Decision on Protest of June 3, 2024, and “Supplement to Protest” of June 20, 2024, submitted by Morrico Equipment for Invitation for Bids IFB-PAG-013-24, re: Procurement of 180’ Telescopic Boom Lift.

Page 11 of 21

to Guam. If the bid pricing existing on the Federal GSA website from a qualified vendor for qualifying items on the date of the opening of the bids, plus the confirmed price of shipping costs to Guam, confirmed after the opening of the bids, is the lowest price, then the contract will be awarded to that vendor.

IFB, General Terms and Conditions, p.25, ¶48.

FCC is Already an Awarded Contractor

The heart of Morrico’s argument is the allegation that FCC “was provided with a *de facto* unfair pricing advantage that other offerors could not avail themselves of” because FCC “provided no bid security” *Morrigo Protest*, p. 1, Bid Protest, ¶ 2 (June 3, 2024);

Morrigo appears to have complaints about differential treatment. However, FCC has a different legal contracting status than Morrico. “*Contractor* means any person having a contract with a governmental body.” 5 GCA § 5030, *contractor*; and 2 GAR, Div. 4, § 1106(6). FCC is an already awarded contractor. Morrico is not. Accordingly, certain laws and terms don’t apply to FCC, and certain laws and terms don’t apply to Morrico.

FCC is an established, awarded MAS contractor with “established catalogue pricing.” 5 GCA § 5030; 2 GAR, Div. 4, § 1106(6) and (24); and FAR § 8.402(b).

MAS Contractors are already legally and contractually obligated to fill all accepted orders from authorized buyers that fall between the minimum and maximum order limits specified in each MAS contract, at the catalog price, pursuant to Federal Acquisition Regulations § 552.238-114, Use of Federal Supply Schedule Contracts by Eligible Non-Federal Entities (NFE’s).

By law, NFE’s may not impose any new terms and conditions that conflict with the primary MAS contract. FAR § 552.238-114(e). Once it is determined that the purchasing entity has imposed no such conflicting requirements, a new task order is issued incorporating any new terms and conditions, and a supplemental contract incorporating all of the terms and conditions of the MAS primary contract is generated. FAR § 552.238-114(d)(1) and (2). Thus, the MAS contract automatically continues in effect for any governmental entities placing orders under the existing primary MAS contract. *Id.*

MAS contractors have already been determined to be responsive and responsible to the nationwide continuous open solicitation. FAR §§ 8.401(a), 38.101(e), and 52.216-1; GSAR §§ 538.270, .271, and .273; and <https://www.highergov.com/idv/GS03F113DA/>. Because FCC has already been required to compete in the open market for its MAS contract, FCC is not simply a bidder, but a pre-vetted, responsible and responsive contractor whose pricing has already been pre-determined to be fair and reasonable. *Id.*

Decision on Protest

Date: July 31, 2024

Subject: Decision on Protest of June 3, 2024, and “Supplement to Protest” of June 20, 2024, submitted by Morrico Equipment for Invitation for Bids IFB-PAG-013-24, re: Procurement of 180’ Telescopic Boom Lift.

Page 12 of 21

Federal Law Prohibits Imposition of a Bid Bond on FCC by the Government of Guam

For MAS contractors, who have already entered into a contract with Fed GSA to supply goods and services, FAR § 28.103-1(c) applies, and expressly prohibits the government of Guam from imposing a bid bond for goods and services on these contractors. It states: “[n]o bond shall be required after the contract has been awarded if it was not specifically required in the contract, except as may be determined necessary for a contract modification.” *Id.*

By law, the government of Guam cannot impose any additional bid bonding requirements on FCC outside of the MAS contract, because it is already an awarded contractor. *Id.*; *see also* FAR §§ 28.103-1(a) and 28.101-1; GSA Contract #GS-03F-113DA; and Multiple Award Schedule Solicitation Document Solicitation Number: 47QSM20R0001.

Because this procurement was funded by federal funds, to the extent that any of the Guam IFB solicitation provisions conflict with federal law, as applied, the federal law controls. This includes any provision of the IFB solicitation document that purports to require FCC to submit a bid bond to the government of Guam.

Federal Law Does Not Prohibit Imposition of a Bid Bond on Morrico by the Government of Guam

Under Guam law, bid bonds are not automatically required for purchases of supplies. They are required when the Procurement Officer makes a finding that a bid bond is necessary to “enforce forfeiture of such bond or deposit if the successful bidder fails to enter into contract within the prescribed time.” 2 GAR, Div. 4 §§ 3109(c)(3)(emphasis added), and 3102(f); *see also* 5 GCA 5212(c).

The purpose of bid bonding and security is to protect the interests of the government by deterring bidders from withdrawing their bids or failing to deliver promised goods or services, because they will otherwise forfeit the bid security to the purchasing entity. This gives the purchasing entity some assurance that the selected bidder will sign the contract and deliver the contracted items or otherwise forfeit their bid bond/security.

FCC already has legal bid security for this IFB in the form of its MAS contract. FCC is already contractually guaranteed to perform and deliver the procured supplies under the contract, and no additional bid bond or bid security can be required from FCC. FAR §§ 28.103-1(a) and (c), 28.101-1; and GSA Contract #GS-03F-113DA.

In contrast, Morrico is not an awarded contractor. It is only a bidder. FAR § 28.001. Morrico does not have an existing, competitively selected IDIQ contract with any governmental entity to supply the items solicited in IFB-PAG-13-024. Morrico has not competed in the open market, and has not been pre-determined to be responsive and responsible. There is no guarantee in place that Morrico will perform the requirements of this IFB. FAR § 28.103-1(c) does not apply to Morrico.

Decision on Protest

Date: July 31, 2024

Subject: Decision on Protest of June 3, 2024, and "Supplement to Protest" of June 20, 2024, submitted by Morrico Equipment for Invitation for Bids IFB-PAG-013-24, re: Procurement of 180' Telescopic Boom Lift.

Page 13 of 21

Therefore, Morrico is required to submit a bid bond as bid security as requested in the IFB because Morrico is under no other contractual or legal obligation to provide the government of Guam with the goods or supplies offered in its bid.

II. FCC is Not Disqualified Based on Licensing:

Untimely: For the same reasons stated in the previous section of the Conclusions, this argument concerning defects in FCC's bid submission is untimely and is entitled to no consideration.

In order to protest, Morrico must be "aggrieved" by the alleged violations of law, and its grievance must be within the Port's authority to remedy under Guam's Procurement Law. 5 GCA § 5425(a).

Morrigo Fails to Request Appropriate Relief: Failure to ask for the appropriate remedy provided by law, failure to specifically set forth the causes of action, or any failure to strictly follow the mandates of the laws or rules conferring jurisdiction upon an adjudicative body deprives the adjudicative body of jurisdiction to hear the matter, and mandates dismissal of the action. *California v. Texas*, 141 S.Ct. 2104, 2115-2116, 210 L.Ed.2d 230 (June 17, 2021) (Plaintiffs were deprived of standing by failing to request the appropriate relief available under the law); and *see e.g., Iwachiw v. New York State Bd. of Elections*, 186 Misc.2d 577, 719 N.Y.S.2d 800 (N.Y.Sup., 2000)(dismissal appropriate where petition failed to state a cause of action based on vague, conclusory allegations, and failed to request the specific relief provided by statute).

Although not clearly stated, Morrico appears to allege that FCC is possibly violating some unidentified business or other licensing laws. It is unclear whether Morrico alleges that FCC is possibly violating Guam laws or the laws of another jurisdiction. Morrico does not set forth what specific "business or other licenses" it believes FCC is required to have.

The Port does not determine what licenses FCC or any other business is required to have or obtain to perform or conduct any business in any jurisdiction. In Guam, the License Board makes such determinations. 11 GCA § 70122.

The Guam Department of Revenue and Taxation ("DRT") is the public body authorized to make determinations of required licensure and to enforce Guam's Business License Law. *See* 11 GCA §§ 70103(j), 70104, and 70122. It is uncertain what "other" licensing laws Morrico is referencing in its Protest; however, if Morrico believes that FCC is in violation of any Guam business licensing requirements, it is required to seek the remedies and enforcement provided for violations of the Guam Business License Law and/or any other appropriate licensing laws from DRT. 11 GCA §§ 70129 and 70131. If Morrico has legitimate claims that FCC, as a business, is violating the provisions of Guam's Business License Law or any other license requirement, Morrico has an adequate remedy available at law, and must file its complaints and pursue its claims of violation with DRT and the License Board, which is the proper entity to determine whether FCC is required to have or maintain any licenses in Guam. 11 GCA §§ 70103(j), 70104, 70122, 70129, and 70131.

Decision on Protest

Date: July 31, 2024

Subject: Decision on Protest of June 3, 2024, and “Supplement to Protest” of June 20, 2024, submitted by Morrico Equipment for Invitation for Bids IFB-PAG-013-24, re: Procurement of 180’ Telescopic Boom Lift.

Page 14 of 21

Morrigo is Not Aggrieved: Morrigo is not aggrieved pursuant to 5 GCA § 5425(a) or 2 GAR, Div. 4 § 9101(a)(1)(a). A protestor must be “legally aggrieved” to have standing. *Teleguam Holdings LLC v. Guam and Pacific Data Systems, Inc.*, 2018 Guam 5 ¶ 14 (internal citation omitted). In order to demonstrate that a protestor is “legally aggrieved” and thereby has standing to pursue a protest, the protestor must adequately establish: (1) an injury in fact (i.e., a “concrete and particularized” invasion of a “legally protected interest”); (2) causation (i.e., a “fairly ... trace[able]” connection between the alleged injury in fact and the alleged conduct of the defending party); and (3) redressability (i.e., it is “likely” and not “merely ‘speculative’” that the plaintiff’s injury will be remedied by the relief plaintiff seeks in bringing suit). *Lujan v. Defenders of Wildlife*, 504 U.S. 555, 560–561 (1992); and *Linsangan v. Gov’t of Guam*, 2020 Guam 27 ¶ 15.

This complaint is vague and ambiguous. Morrigo does not clearly set forth any concrete wrongdoing, and does not state any particular law or laws of any jurisdiction which FCC is supposed to be violating, if any. If FCC is, in fact, failing to obtain appropriate licenses from any required jurisdiction, then FCC may be subject to penalties for such violations in that appropriate jurisdiction. However, such violations are committed against the governing bodies of those jurisdictions, the violations are not committed against Morrigo. Morrigo fails to demonstrate how the alleged failure of a competing business to obtain any unspecified licenses deprived Morrigo of its ability to participate in this procurement, or deprived Morrigo of any other rights that Morrigo may have to conduct its own business.

This Complaint Has No Merit: Morrigo claims that FCC’s alleged failure “to have necessary business and other licenses needed to make sales to the Port” renders FCC non-responsible and non-responsive to this solicitation. *Morrigo Protest*, p. 1, Bid Protest, ¶ 2. However, the IFB did not require vendors to submit any proof of any licensure with their bid submissions. Therefore, this complaint concerns only FCC’s responsibility, not its responsiveness to the IFB.

As already discussed, as an awardee of an MAS contract, FCC has already been determined to be responsible, FAR §§ 8.402(c)(2), 8.401(a), 8.404(d), 9.103(a), 38.101(e), and 52.216-1; GSAR §§ 538.270, .271, and .273; and GSA Contract #GS-03F-113DA, and FCC is specifically authorized to enter into contracts with the government of Guam for supplies and services. 48 U.S.C. § 1469e and 40 U.S.C. § 502(c)(2); and GSAR § 552.238-114.

This determination of responsibility required review and approval of “the performance and integrity information available in the Federal Awardee Performance and Integrity Information System (FAPIIS), (available at <https://www.cpars.gov>), including FAPIIS information from the *System for Award Management (SAM)* Exclusions and the Contractor Performance Assessment Reporting System (CPARS).” FAR § 9.104-6(a)(1).

The determination of responsibility does not mandate review of any licensing requirements under federal law or Guam law. FAR § 9.104-1; 2 GAR, Div. 4 § 3116(b)(2).

Decision on Protest

Date: July 31, 2024

Subject: Decision on Protest of June 3, 2024, and “Supplement to Protest” of June 20, 2024, submitted by Morrico Equipment for Invitation for Bids IFB-PAG-013-24, re: Procurement of 180’ Telescopic Boom Lift.

Page 15 of 21

Guam law requires only that “[b]efore awarding a contract, the Procurement Officer must be satisfied that the prospective contractor is responsible.” 2 GAR, Div. 4 § 3116(b)(2). Bidders or contractors are not required to provide proof of responsibility unless requested. 2 GAR, Div. 4 § 3116(b)(2)(B) and (b)(3).

Guam’s Procurement Law does not require a contractor to have any particular licensing and does not govern such concerns. The IFB provides that bidders must “compl[y] with Guam’s Licensing Law. Specific information on licenses may be obtained from the Director of Revenue and Taxation.” *IFB*, General Terms and Conditions, p.22, ¶ 4. The solicitation does not require FCC or any bidders to provide any proof or copies of any specific licensure with any bid submissions. FCC’s submission did not fail to comply with the requirements of the IFB.

A solicitation provision mandating that the contractor comply with all necessary licenses or permits needed to perform the work does not require that a bidder or offeror provide proof or documentation of compliance prior to award. *Mid-America Mgmt. Servs., Inc.*, B-244103, June 5, 1991, 91-1 CPD ¶ 537 at 1-2. The securing of licenses and permits is a performance requirement that may be satisfied during contract performance and does not affect the award decision. *HAP Constr., Inc.*, B-278515, Feb. 9, 1998, 98-1 CPD ¶ 48 at 2-3.

As applied to a requirement for licensing, if a solicitation does not obligate a bidder to provide a particular license before award, it is not a definitive responsibility criterion; rather, it is a contract performance requirement that does not affect a decision to award a contract. *Restec Contractors, Inc.*, B-245862, Feb. 6, 1992, 92-1 CPD ¶ 154 at 4; *see also Evergreen Int’l Airlines, Inc.*, B-244284, Aug. 15, 1991, 91-2 CPD ¶ 154 at 3*.

There are multiple ways to comply with business licensing laws in Guam without obtaining a Guam Business License, including the exemption granted pursuant to 11 GCA § 70126(a) for business that is conducted “for the sole and direct benefit of or under the direct supervision of the Government of Guam.” *Id.* Furthermore, certain businesses are not required to obtain a Guam Business License for certain acts, including: “(6) soliciting or procuring orders, whether by mail or through employees or agents or otherwise, where those orders require acceptance outside Guam before they become binding contracts; ... and (11) transacting business in interstate commerce.” 11 GCA § 70103(e)(6) and (11). FCC is transacting business in interstate commerce. FCC’s sale of a boom lift to the Port is for the sole and direct benefit of the Port. FCC’s MAS offerings are not available commercially in Guam, and can only be sold to federal entities and the government of Guam by orders placed through the Federal Supply Schedule. 48 U.S.C. 1469e; FAR Part 38; and GSAR § 552.238-114. Although the Port does not here make any formal determinations regarding licensure, it appears that FCC is not required to have a Guam Business License, and is complying with licensing laws.

The Port is satisfied that FCC is a responsible contractor.

Decision on Protest

Date: July 31, 2024

Subject: Decision on Protest of June 3, 2024, and "Supplement to Protest" of June 20, 2024, submitted by Morrico Equipment for Invitation for Bids IFB-PAG-013-24, re: Procurement of 180' Telescopic Boom Lift.

Page 16 of 21

III. FCC's Bid is Not Disqualified Based on Failure to Select Bid Options

Untimely: For the same reasons stated in the previous sections of the Conclusions, this argument concerning defects in FCC's bid submission is untimely and is entitled to no consideration.

This Complaint Has No Merit: The Port now addresses the remainder of Morrico's allegations. Morrico claims that:

- a) "FCC failed to execute and provide the required "Special Reminder to Prospective Bidders";
- b) FCC is "non-responsive in refusing to provide training as described and required on page 32 of the IFB";
- c) "FCC refused to offer and provide the warranty required by the IFB";
- d) "FCC refused to offer and provide technical assistance as sought on page 33 of the IFB;
- e) "FCC refused to offer and provide service as required on page 33 of the IFB;
- f) "FCC does not have a local authorized dealer as required on page 33 of the IFB; and
- g) "FCC refused to provide complete familiarization training as required on page 33 of the IFB."

Although Morrico claims that these items affect both FCC's responsibility and responsiveness, these factors do not implicate FCC's fitness to perform the contract; they only involve FCC's responsiveness to the IFB.

1) Execution of the Special Reminder to Prospective Bidders Form is Not Required

Morrigo makes multiple allegations that simply are not accurate. First among these, Morrico claims that execution of the Special Reminder to Prospective Bidders form is "required," and therefore FCC's bid submission should be rejected as non-responsive. This is incorrect. Failure to execute the reminder form "may be cause for disqualification and rejection of the bid." *IFB, Special Reminder to Prospective Bidders*, p. 1. "Shall is mandatory and *may* is permissive." 1 GCA § 715(h)(9). The IFB does not require rejection of FCC's bid for failure to execute or provide the Special Reminder form.

2) All Bid Items are Not Required To be Bid

Morrigo further claims that multiple alternate bidding items included in the IFB are mandatory, and not optional. These terms include training, warranty, technical assistance, service, and requiring the manufacturer to have a local dealer.

Morrigo confuses "specifications" with bid items. "Specification means any description of the physical or functional characteristics, or of the nature of a supply, service, or construction item. 5 GCA § 5260(emphases added); *see also* 2 GAR, Div. 4 § 4101(4). A bid item is a specific, distinct unit of supply, service, or construction for which individual specifications are created (also sometimes referred to as "line items"). *Id.*; § 4103(b)(1)(b) and (d); and FAR § 4.1003; "The purpose of a specification is to serve as a basis for obtaining a supply, service, or construction item ..." 2 GAR, Div. 4 § 4102(a)(1) (emphases added).

Decision on Protest

Date: July 31, 2024

Subject: Decision on Protest of June 3, 2024, and “Supplement to Protest” of June 20, 2024, submitted by Morrico Equipment for Invitation for Bids IFB-PAG-013-24, re: Procurement of 180’ Telescopic Boom Lift.

Page 17 of 21

Morrice apparently argues that training, warranty, technical assistance, service, and requiring the manufacturer to have a local dealer are all part of the characteristics of a boom lift. This is not accurate. These are separate bid items, as each constitutes a separate service that is not part of the physical or functional characteristics, or nature of the boom lift specifications. FAR § 4.1003(a)(1) and (2) “(1) A supply is separately identifiable if it has its own identification (*e.g.*, national stock number (NSN), item description, manufacturer’s part number). (2) Services are separately identifiable if they have no more than one statement of work or performance work statement.”). The boom lift is a supply item with its own purchase description, manufacturer’s number, and an established fixed delivery date; but the training, warranty, technical assistance, and other service items each have their own separate delivery requirements, period(s) of performance, locations of performance, and no associated manufacturer’s numbers, since they are not supply items. FAR § 4.1003(d).

Multiple and/or alternate bid items may be included in an IFB. 2 GAR, Div. 4 § 3102(d). Likewise, a solicitation may or may not require a bidder to bid on all bid items. “All or None Bids or Proposals. Only when provided by the solicitation may a bid or proposal limit acceptance to the entire bid or proposal offering. Otherwise, such bids or proposals shall be deemed to be nonresponsive.” 2 GAR, Div. 4 § 3115(f).

The Port specifically did not require the bidders to bid all bid items, and did not include a limitation of the Port’s acceptance of the bids to all bid items or none. The IFB shows that check box #7 in the General Terms and Conditions is not checked. It explicitly states: “‘ALL OR NONE’ BIDS: NOTE: By checking this item, the Government is requesting all of the bid items to be bided (*sic*) or none at all.” *IFB*, General Terms and Conditions, p. 22, ¶ 7. The Port did not require all bid items to be bid for this IFB. The Port is not limited to acceptance of an entire bid and all bid items or nothing.

In this IFB, the Port is specifically authorized to “award, cancel, or reject bids in whole or in part for any one or more items” if it is in the best interests of the government. *IFB*, General Terms and Conditions, p. 23, ¶ 22; and 2 GAR, Div. 4 § 3115(e)(2). The Government reserves the right to increase or decrease the quantity of the items for award and make additional awards for the same type items and the vendor agrees to such modifications and additional awards ... after original award.” *IFB*, General Terms and Conditions, p. 23, ¶ 22.

The Port may award on any part of the bid submissions and reject the remainder of any bid items it does not need. 2 GAR, Div. 4 §§ 3115(f). The Port may further make additional awards of the separate bid items after the original award of the accepted bid items. *Ids.* Individual awards may be made for the items or combinations of bid items that result in the best interests of serving the needs of the Port. The Port was not required to award on all of the different and optional bid items.

Decision on Protest

Date: July 31, 2024

Subject: Decision on Protest of June 3, 2024, and “Supplement to Protest” of June 20, 2024, submitted by Morrico Equipment for Invitation for Bids IFB-PAG-013-24, re: Procurement of 180’ Telescopic Boom Lift.

Page 18 of 21

The Port awarded a contract for the purchase of the boom lift, and was not required to award a contract for all of the listed bid items, including training, warranty, technical assistance, service, and requiring the manufacturer to have a local dealer¹.

IV. The Port Complied with Morrico’s Records Request

Morrigo submitted a “Sunshine Reform Act” request on June 3, 2024, and the Port responded to this request in writing on June 5, 2024. The Port then produced the entire procurement record for Morrico. Morrico’s claims of any non-compliance with any law are factually and legally inaccurate. Morrico has not set forth any violation of any law, nor has it requested any relief for any alleged failure to comply with any records request. 2 GAR, Div. 4 §§ 9104, 9105, 9106; and 5 GCA §§ 5451 and 5452.

Untimely: The facts concerning the Sunshine Reform Act request upon which Morrico bases this complaint were known to Morrico as of June 5, 2024, which is the date that Morrico states that the Port “declined to comply with the Sunshine Act request” *Morrigo Supplemental Protest*, p. 1, ¶ 1. In order to file a protest on this factual basis, Morrico would have been required to submit a protest concerning these facts on or before June 19, 2024. This particular complaint was first raised in the Supplemental Protest filed on June 20, 2024, and is untimely.

Morrigo is Not Aggrieved: Guam adopted its procurement statutes and regulations in 1983 from the 1979 Model Procurement Code promulgated by the American Bar Association. Accordingly, case law from other states interpreting similarly adopted versions of the ABA Model Procurement Code constitutes persuasive case law in Guam. *Gibbs v. Holmes*, 2001 Guam 11, ¶ 15.

The state of Indiana adopted a similar version of the ABA Model Procurement Code in 1981. In *City of Fort Wayne v. Pierce Mfg., Inc.*, 853 N.E.2d 508 (Ind. Ct. App. 2006), the Indiana Court of Appeals conducted an in-depth analysis of the meaning of the term “person aggrieved,” and concluded that an unsuccessful bidder did not have standing to maintain suit for alleged violations of procurement rules that did not affect the bidder’s ability to participate in the procurement process; therefore, it could not show that it suffered any injury to its pecuniary, property, or personal interests for such immaterial breaches of procedure. *Id.* at 517.

Even if taken as true, at best, Morrico’s statement describes non-compliance with a records request that occurred *after* it discovered that award of IFB-PAG-013-24 was made to another bidder. Morrico has not been prevented from participating in the procurement process by any alleged non-compliance with its records request, and is not “aggrieved.” A “conjectural or hypothetical” injury to “the process” will not satisfy the requirements necessary to establish standing. *Lujan v. Defenders of Wildlife*, 504 U.S. 555, 560–61 (1992). No facts alleged in this fourth complaint

¹ Requiring a third-party manufacturer, such as JLG, who is not a vendor or bidder, and is not a participant in the procurement, to maintain a local authorized dealer is not a valid or enforceable bid item.

Decision on Protest

Date: July 31, 2024

Subject: Decision on Protest of June 3, 2024, and "Supplement to Protest" of June 20, 2024, submitted by Morrico Equipment for Invitation for Bids IFB-PAG-013-24, re: Procurement of 180' Telescopic Boom Lift.

Page 19 of 21

regarding Morrico's Sunshine Reform Act request operated to penalize Morrico or prevent Morrico from participating in this solicitation or the IFB process. Morrico is not suffering, nor will suffer any injury to any personal, property, or pecuniary rights stemming from its records request. Whether the Port appropriately responded to the Sunshine Reform Act request is irrelevant to Morrico's participation in this IFB. Even if a court were to find in favor of Morrico on this claim, there is no detriment to Morrico. Morrico has entirely failed to assert "entitlement" to any relief under Guam's Procurement Law, or any other law.

Morrigo has suffered no injury, and is not aggrieved by any possible alleged violation of the Sunshine Reform Act or other laws governing records requests.

Morrigo Requests No Relief: In this fourth enumerated complaint, Morrico does not ask for any relief under any statute or rule. Morrico has not specifically alleged any violation of any law, and has failed to request any redress or remedy available for a procurement protest or otherwise. 2 GAR, Div. 4 §§ 9104, 9105, 9106; and 5 GCA §§ 5451 and 5452. Morrico merely characterizes the Port's timely response making the record available to Morrico as "declin[ing] to comply." *Morrigo Supplemental Protest*, p. 1, ¶ 1. Morrico entirely fails to request an available legal remedy for any possible suggested violation, stating only that "[o]ur team eventually did review the records, and that review has necessitated this protest supplement." *Morrigo Supplemental Protest*, p. 1, ¶ 1. Even if this "complaint" in the Protest were to be sustained, there is no request for an available remedy that can be granted, and therefore, no "injury ... that is likely to be redressed by a favorable decision." *Simon v. E. Kentucky Welfare Rights Org.*, 426 U.S. 26, 38 (1976).

This Complaint Alleges no Violation of Law: In order to sustain a protest, it must be determined that the solicitation or award "is in violation of law." 2 GAR, Div. § 9104(a)(1); and 5 GCA § 5450. Morrico's fourth enumerated complaint fails to allege any violations of the laws or rules governing procurements. Further, Morrico makes no claim that the Sunshine Reform Act was violated. Regarding this fourth complaint, Morrico makes no explicit claim that any law was violated. There is no remedy available where there has been no violation of law.

Even if Morrico were to allege specific violations of Guam's Sunshine Reform Act (which it has not), Morrico would be required to seek the remedies provided for violations of the Sunshine Reform Act (which it has not). *See* 5 GCA § 10108; and *M.S. v. Brown*, 902 F.3d 1076, 1082, 1083-1090 (9th Cir. 2018) (Even where a plaintiff requests relief that could redress a claimed injury, there is no redressability, as required for standing, if the requested relief is beyond the scope of available relief).

Morrigo fails to indicate any procurement provision or other law which has been violated, and fails to show any prejudice stemming from any such violation. Therefore, it must be denied.

This Complaint Has No Merit: The Port has no duty to deliver or send Morrico copies of any records under any law.

Decision on Protest

Date: July 31, 2024

Subject: Decision on Protest of June 3, 2024, and “Supplement to Protest” of June 20, 2024, submitted by Morrico Equipment for Invitation for Bids IFB-PAG-013-24, re: Procurement of 180’ Telescopic Boom Lift.

Page 20 of 21

5 GCA § 5251 states: “Public Record. The record required by § 5249 of this Chapter is a public record and, subject to rules promulgated by the Public Auditor, any person may inspect and copy any portion of the record.” *Id.* (emphases added).

Under Guam’s Procurement Law, a party has a right to access the procurement records current to the present stage of the procurement, which are public and not confidential, to inspect them and make copies of any portions of these records. 5 GCA § 5252. A party does not have the right to demand transmission of any records in an unspecified format to an unspecified location, especially without providing payment of any associated costs.

The Sunshine Reform Act (SRA) is also clear in this matter. 5 GCA § 10103 is entitled “Right of *Inspection of Public Documents.*” 5 GCA § 10103 (emphasis added). It states:

(a) Every person has the right to inspect and take a copy of any public document on Guam, except as otherwise expressly prohibited in law, and except as provided in § 10108 of this Chapter. (b) Public records are open to inspection at all times during the office hours of the agency and every person has a right to inspect any public record, . . .”

5 GCA § 10103(a)(emphases added).

Pursuant to the SRA, a party has a right to go to the office of any public agency to inspect and then explicitly identify the records of which it would like copies, in any reasonable form. The party must clearly identify the documents sought. A party does not have the right to make public employees guess at which records a party would like to take copies of, or deliver unspecified copies to an unidentified location (online or otherwise), without having the party inspect and clearly identify specific documents, and then pay any fees for reproduction of those documents in a specified available format. 5 GCA §§ 10103(c) (agencies “shall make the records promptly available to any person, upon payment of fees covering direct costs of duplication, or a statutory fee, if applicable.”); and 10104(b). 5 GCA § 10201 reiterates that a party only has a right to inspection prior to taking any copies in any specified form:

Inspection of Public Records; Certified Copies. Every person has a right to inspect any public writing on record in Guam and every public officer having the custody thereof is bound to permit such inspection, and to give on demand and on payment of the legal fees therefor a certified copy of such writing or record.

5 GCA § 10201 (emphases added).

Morrigo did not identify particular documents for copying or transmission, and never requested production of any records in any specified manner or format, electronic or not. Morrigo’s request did not even supply an email, physical address, or other means of transmission for any subject records, stating only “provide to the company the complete procurement record” *Morrigo*

Decision on Protest

Date: July 31, 2024

Subject: Decision on Protest of June 3, 2024, and "Supplement to Protest" of June 20, 2024, submitted by Morrico Equipment for Invitation for Bids IFB-PAG-013-24, re: Procurement of 180' Telescopic Boom Lift.

Page 21 of 21

Protest, p. 2, Sunshine Act Request. Despite this vague missive, the Port immediately responded to Morrico's request, and produced the entire procurement records for IFB-PAG-013-24 and IFB-PAG-004-24, so that Morrico could inspect these records and then identify and take copies of any documents it needed, in any readily available format. There is no legal or factual merit to Morrico's allegation that the Port "declined to comply with the Sunshine Act request," *Morrigo Supplemental Protest*, p. 1, ¶ 1, and this protest complaint is denied on this basis as well.

SUMMARY OF CONCLUSIONS:

Morrigo's Protest is untimely, as it was filed more than 14 days after Morrico knew or should have known of the complaints it has lodged regarding FCC's bid submission, which was public on May 8, 2024. Morrico's complaints in the Protest and Supplemental Protest are not entitled to any consideration. Further, the contract was already awarded, documented, and made known to everyone, including the successful vendor (FCC) and the unsuccessful vendor (Morrico) through the Notice of Award issued on May 20, 2024. Accordingly, the stay provisions were not triggered.

Morrigo's additional complaint of any "declined" records request is also legally and factually unfounded. Finally, even if the Port were to consider Morrico's untimely protest(s), there is no merit to any of Morrico's complaints regarding the selection of FCC as the lowest, responsible, responsive vendor. Morrico is not aggrieved. Morrico was not harmed or prejudiced in any way, nor prevented from competing or having its bid duly considered in a full and open competitive selection procedure.

Pursuant to 5 GCA § 5425(c) this decision is final and conclusive. Protestor is advised that it has the right to administrative and judicial review.



Rory J. Respicio, General Manager
Procurement Officer
Port Authority of Guam

8a

RAZZANO WALSH & TORRES, P.C.
 JOSEPH C. RAZZANO
 JOSHUA D. WALSH
 PAN AMERICAN BUILDING
 Suite 100, 139 Murray Blvd.
 Hagåtña, Guam 96910
 Telephone: (671) 989-3009
 Facsimile: (671) 989-8750
 Electronic Service: eservice@rwtguam.com

Counsel for Appellant Morrigo Equipment, LLC

PROCUREMENT APPEAL OF DENIAL OF PROCUREMENT PROTEST
THE OFFICE OF PUBLIC ACCOUNTABILITY

PART I.

In the Procurement Appeal of)	NOTICE OF PROCUREMENT
)	APPEAL
MORRICO EQUIPMENT, LLC,)	
)	
Appellant.)	Docket No. OPA-PA_____
_____)	

PART II: APPELLANT INFORMATION

Appellant's Name	Morrigo Equipment, LLC ("Morrigo")
Appellant's Mailing Address	197 Ypao Road, Tamuning, Guam, 96913
Appellant's Business Address	197 Ypao Road, Tamuning, Guam, 96913
Appellant Representative's Direct Email Address	joel.lesh@morrigoequipment.com
Appellant's Phone	671-649-1946

Appellant's Facsimile	671-649-1947
-----------------------	--------------

Appellant is represented by legal counsel in this appeal. For purposes of this appeal, please direct correspondence to Morrico Equipment, LLC ("Morrico") lead counsel, Joseph C. Razzano of Razzano Walsh & Torres, P.C.

Counsel's Mailing Address	139 Murray Blvd. Ste. 100, Hagåtña, Guam 9691
Counsel's Telephone	671-989-3009
Counsel's Facsimile	671-989-8750
Counsel's Direct Email Address	jrazzano@rwtguam.com

PART III: APPEAL INFORMATION

- A. Purchasing Agency: Port Authority of Guam ("PAG" or the "Port").
- B. Solicitation Number: Port Authority of Guam IFB# IFB-PAG-013-24.
- C. The Decision being appealed was provided to the Appellant on July 31, 2024. The Decision was made by the agency General Manager, Rory J. Respicio.
- D. This Appeal is made from the Decision on Protest to Morrico via email on July 31, 2024.
- E. The name of the only competing offeror known to Appellant is: Federal Contracts Corporation ("FCC").

///

///

PART IV: STATEMENT OF GROUNDS FOR APPEAL

A. THE GROUNDS FOR APPEAL

1. Relevant Procedural and Factual History

On January 26, 2024, the PAG issued IFB-PAG-004-24, seeking a 180' Telescopic Boom Lift. Morrico was the lowest priced responsive bidder for that tender, but when Morrico refused to unilaterally drop its quoted price, PAG cancelled the IFB. The Port then issued IFB-PAG-013-24 on April 23, 2024, seeking the exact same item. IFB p. 3, attached to this Notice of Appeal as **Exhibit A**.

On May 7, 2024, Morrico submitted its bid. On May 20, 2024, the Port informed Morrico that, despite being the only fully responsive bidder to the IFB, the Port instead intended to enter into a contract with Federal Contracts Corp ("FCC"). Notice of Award, Attached to this Notice of Appeal as **Exhibit B**. The Bid Abstract assembled by the Port's procurement team confirms that FCC failed to provide the bid security necessary for a responsive bid, and also failed to have the necessary business and other licenses needed to make sales to the Port. The Port's notice on May 20, 2024, of the FCC meant that the Port not only selected a non-responsive offeror to perform the work of the IFB, but also selected a party that could not responsibly perform under the laws of Guam the way that Morrico can. Morrico submitted its Bid Protest to the PAG on June 3, 2024. Bid Protest 1, attached to this Notice of Appeal as **Exhibit C**.

Morrico personnel were subsequently able to review procurement documents made available by PAG staff, and that review showed that not only did FCC both fail to

provide the bid security necessary for a responsive bid and fail to have the licenses necessary to do the work, but their bid submission was also non-responsive and did not comport with the IFB's plain requirements for multiple other reasons:

1. FCC failed to execute and provide the required Special Reminder to Prospective Bidders;

2. FCC failed execute and provide the Bid Bond form;

3. FCC was explicitly non-responsive in refusing to provide training as described and required on page 32 of the IFB;

4. FCC refused to offer and provide the warranty required by the IFB;

5. FCC refused to offer and provide technical assistance as sought on page 33 of the IFB;

6. FCC refused to offer and provide service as required on page 33 of the IFB;

7. FCC does not have a local authorized dealer as required on page 33 of the IFB; and

8. FCC refused to provide complete familiarization training as required on page 33 of the IFB.

These additional non-conforming issues compelled Morrigo to submit a second Bid Protest on these issues on June 20, 2024. Bid Protest 2, attached to this Notice of Appeal as Exhibit D. PAG Denied the Bid Protests on July 31, 2024. Decision on protest, attached as Exhibit E.

2. Timeliness of Protest and Appeal.

The Port's May 20, 2024, decision to select a non-responsive offeror constituted a mistake. GCA 5 §5425(a) requires that Protests must be made within 14 days of the issues leading to the protest being known by the Protester (Morricco in this case). Morricco learned more about the Port's error in selecting a non-responsive offeror on the same day it received the award notice — May 20, 2024. Morricco raised its protest to PAG on June 3, 2024, and raised newly discovered issues on June 20, 2024.

This Appeal comes within fifteen days after PAG issued its protest decision to Morricco on July 31, 2024, and is within the fifteen-day protest appeal period set by 5 GCA § 5425(e). Therefore, both Morricco's agency level protest and subsequent appeal to the OPA meet the timeliness standards required by applicable law and regulation.

3. Basis for Protest and Appeal: PAG has selected a non-responsive and non-responsible offeror.

The Port's selection on May 20, 2024, of the FCC bid meant that the Port not only selected a non-responsive offeror to perform the work of the IFB, but also selected a party that could not responsibly perform under the laws of Guam the way that Morricco can. The Port's apparent decision to select an offeror who provided no bid security also meant that FCC was provided with a *de facto* unfair pricing advantage that other offerors could not avail themselves of. PAG's decision to ignore other areas of FCC non-responsiveness constitutes a fundamental and material change the specifications that only benefitted FCC, as no other bidder was allowed to deviate from complying with the IFB.

B. RULING REQUESTED

Morrigo respectfully requests that the Office of Public Accountability issue an Order declaring the following:

- (1) That PAG's decision to make an award to FCC despite FCC's failure to adhere to the requirements of the IFB was arbitrary, capricious and an abuse of discretion;
- (2) That PAG's denial of Morrigo's protests was unreasonable, arbitrary, capricious and an abuse of discretion;
- (3) That the automatic stay of procurement arising under 5 G.C.A. §5425(g) be confirmed in place;
- (4) That Morrigo, as the lowest priced responsive and responsible bidder under the IFB, be named for award of the IFB; and
- (5) For such further relief that the OPA deems appropriate.

C. SUPPORTING EXHIBITS, EVIDENCE OR DOCUMENTS

Submitted with this appeal are the following supporting exhibits, evidence, and documents:

1. Invitation for Bid, April 23, 2024
2. Notice of Award, May 20, 2024
3. Bid Protest, June 3, 2024

PART V: DECLARATION RE: COURT ACTION

The undersigned does hereby confirm that to the best of his knowledge, no case or action concerning the IFB that is subject of this Appeal has been commenced in court. The undersigned party agrees to notify the Office of Public Accountability within 24 hours if court action commences regarding this Appeal or the underlying procurement action.

Respectfully submitted this 14th day of August 2024.

RAZZANO WALSH & TORRES, P.C.

By: 

JOSEPH C. RAZZANO
JOSHUA D. WALSH
*Attorneys for Appellant Morrico
Equipment LLC.*

VERIFICATION

I, Jesse Munoz, a duly authorized representative of Appellant Morrico, hereby declares under penalty of perjury under the laws of Guam that I have read the foregoing Notice of Appeal and that it is true and correct of my own knowledge, except as to those matters alleged upon information and belief and as to those matters, I believe them to be true.

Dated this 14th day of August 2024.

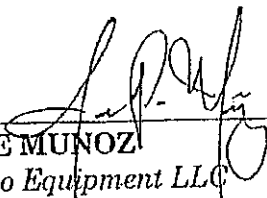

JESSE MUNOZ
Morrico Equipment LLC

EXHIBIT A



PORT OF GUAM
ATURIDAT / PUEYTON GUAHAN
Jose D. Leon Guerrero Commercial Port
 1026 Cabras Highway, Suite 201, Pld, Guam 96925
 Telephone: 671-477-5931/35 Facsimile: 671-477-2689/4445
 Website: www.portguam.com

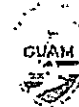

Lourdes A. Leon Guerrero
 Governor of Guam
 Joshua F. Tenorio
 Lieutenant Governor

Accountability * Impartiality * Competence * Openness * Value

INVITATION FOR BID NO.: IFB-PAG-013-24

DESCRIPTION:

Re-bid 180' Telescopic Boom Lift

SPECIAL REMINDER TO PROSPECTIVE BIDDERS

Bidders are reminded to read the Sealed Bid Solicitation and Instructions, and General Terms and Conditions attached to the IFB to ascertain that all of the following requirements checked below are submitted in the bid envelope. If hard copies are submitted, One (1) original, one (1) copy, and one (1) CD or USB containing electronic file copy (in PDF format) of the complete bid proposal shall be enclosed in a sealed package or envelope at the date and time for bid opening; or bid may be submitted electronically via e-mail before the deadline, see instructions below. No award will be made until bid security is confirmed.

[X] **BID GUARANTEE (15% of Bid Amount) May be in the form of;**
Reference #11 on the General Terms and Conditions

- a. Cashier's Check or Certified Check
- b. Letter of Credit
- c. Surety Bond – Valid only if accompanied by:
 - 1. Current Certificate of Authority issued by the Insurance Commissioner;
 - 2. Power of Attorney issued by the Surety to the Resident General Agent;
 - 3. Power of Attorney issued by two (2) major officers of the Surety to whoever is signing on their behalf.

[X] **BROCHURES/DESCRIPTIVE LITERATURE;**

[X] **AFFIDAVIT DISCLOSING OWNERSHIP and COMMISSION**

- a. Date of signature of the person authorized to sign the bid and the notary date must be the same.

[X] **OTHER REQUIREMENTS:**

Disclosure of Shareholder & Commission, Non-Collusion Declaration, D.O.L. Wage Determination Declaration, Restriction against Sexual Offenders Declaration, No Kickbacks or Gratuities Declaration and Ethical Standards Declaration, and Declaration re Contingent Fees, Conflict of Interest Form, SF-LLL Byrd Anti-Lobbying, and Current Business License at the time of the award.

This reminder must be signed and returned in the bid envelope together with the bid. Failure to comply with the above requirements may be cause for disqualification and rejection of the bid.

On this _____ day of _____, 2024, I, _____,

authorized representative of _____ acknowledge receipt of this special reminder to prospective bidders with the above referenced IFB.

 Bidder Representative's Signature

INVITATION FOR BID NO.: IFB-PAG-013-24

Re-bid 180' Telescopic Boom Lift

ACKNOWLEDGEMENT RECEIPT FORM

Please be advised that to be considered a prospective bidder you must fill out this Acknowledgement receipt form. Please submit by fax form to (671) 472-1439 or email to macabrera@portofguam.com, and pagprocurement@portofguam.com

Acknowledgement Receipt Form must be submitted no later than three (3) days upon receipt of IFB package.

Name _____
Signature _____
Date _____
Time _____
Contact Number _____
Fax Number _____
Contact Person regarding IFB _____
Title _____
E-Mail Address _____
Company/Firm _____
Address _____

Note: IFB recommends that prospective bidders register current contact information with IFB to ensure they receive any notices regarding any changes or update to the IFB. The procuring agency and IFB will not be liable for failure to provide notice to any party who did not register current contact information.

All questions and concerns in regards to this bid must be submitted to the PORT AUTHORITY OF GUAM via fax or email, addressed to the GENERAL MANAGER no later than Wednesday, May 1, 2024 by the close of business at 5:00pm. Your inquiry may be sent by fax to (671)472-1439, or emailed to rjrespicio@portofguam.com and copied to pagprocurement@portofguam.com, algsablan@portofguam.com, and macabrera@portofguam.com.

No Entitlement to Preparation Costs – the bidder expressly waives any right it may have against the government for any expenses incurred in connection with the preparation of its bid.

INVITATION FOR BID

ISSUING OFFICE:
PORT AUTHORITY OF GUAM
GOVERNMENT OF GUAM
1026 CABRAS HIGHWAY, SUITE 201,
PITI, GUAM 96915

Rory J. Respicio
RORY J. RESPICIO
GENERAL MANAGER

DATE ISSUED: 4/23/2024

BID INVITATION NO: IFB/PAG-013-24

BID FOR: Re-bid 180' Telescopic Boom Lift

SPECIFICATION: SEE BELOW

DESTINATION: PORT AUTHORITY OF GUAM

REQUIRED DELIVERY DATE: (460 days ARO) upon receipt of purchase order. Delivery schedule time and quantity will be coordinated between the successful bidder and the requesting department in accordance with the schedules contained in MARAD FY2022 American Marine Highway (AMH) Grant No. 693JF72340007, and in accordance with the expiration date of this grant, currently set to expire on May 1, 2026. This project is funded by the MARAD FY2022 American Marine Highway (AMH) Grant No.: 693JF72340007.

INSTRUCTION TO BIDDERS:

INDICATE WHETHER: INDIVIDUAL PARTNERSHIP CORPORATION

INCORPORATED IN: _____

This bid shall be submitted in duplicate with electronic copy (pdf format) and sealed to the issuing office above no later than (Time) 2:00 PM Date: WEDNESDAY, May 8, 2024 and shall be publicly opened. Alternatively, bids may be submitted via e-mail prior to the due date and time above; please refer to the instructions below. Any bid submitted after the time and date specified above shall be rejected. See attached General Terms and Conditions, and Sealed Bid Solicitation for details.

The undersigned offers and agrees to furnish within the time specified, the articles and services at the price stated opposite the respective items listed on the schedule provided, unless otherwise specified by the bidder. In consideration to the expense of the Government in opening, tabulating, and evaluating this and other bids, and other considerations, the undersigned agrees that this bid remain firm and irrevocable within 90 calendar days from the date opening to supply any or all the items which prices are quoted.

NAME AND ADDRESS OF BIDDER:

SIGNATURE AND TITLE OF PERSON
AUTHORIZED TO SIGN THIS BID:

AWARD: CONTRACT NO.: _____ AMOUNT: _____ DATE: _____

ITEM NO(S). AWARDED: _____

NAME AND ADDRESS OF CONTRACTOR:

CONTRACTING OFFICER:

RORY J. RESPICIO
General Manager

SIGNATURE AND TITLE OF PERSON
AUTHORIZED TO SIGN THIS CONTRACT:

Name: _____

Title: _____ Date: _____

SPECIAL PROVISIONS

Contract Period:

The term of this contract will continue until the expiration of the grant funds under MARAD FY2022 American Marine Highway (AMH) Grant No.: 693JF72340007 and may be extended if the period of performance for the grant funds is extended in accordance with the federal award terms and conditions. The current expiration date of the grant funds is May 1, 2026.

The initial purchase of one (1) Re-bid 180' Telescopic Boom Lift is funded by MARAD FY2022 American Marine Highway (AMH) Grant No. 693JF72340007

Contract incorporates all applicable provision of the Port Authority of Guam Federal Contract Supplement.

GOVERNMENT OF GUAM

THE PORT AUTHORITY OF GUAM
1026 Cabras Highway, Suite 201
Piti, Guam 96915

BID BOND

NO. _____

KNOW ALL MEN BY THESE PRESENTS that _____, as Principal hereinafter called the Principal, and (Bonding Company), _____ A duly admitted insurer under the laws of the Territory of Guam, as Surety, hereinafter called the Surety are Held firmly bound unto the Territory of Guam for the sum of _____ Dollars (\$ _____), for Payment of which sum will and truly to be made, the said Principal and the said Surety bind ourselves, our heirs, executors, administrators, successors and assigns, jointly and severally, firmly by these presents.

WHEREAS, the Principal has submitted a bid for (Identify project by number and brief description)

NOW, THEREFORE, if the Territory of Guam shall accept the bid of the Principal and the Principal shall enter into a Contract with the Territory of Guam in accordance with the terms of such bid, and give such bond or bonds as may be specified in bidding or Contract Documents with good and sufficient surety for the faithful performance of such Contract and for the prompt payment of labor and material furnished in the prosecution thereof, or in the event of the failure of the Principal to enter such Contract and give such bond or bonds, if the Principal shall pay to the Territory of Guam the difference not to exceed the penalty hereof between the amounts specified in said bid and such larger amount for which the Territory of Guam may in good faith contract with another party to perform work covered by said bid or an appropriate liquidated amount as specified in the Invitation for Bids then this obligation shall be null and void, otherwise to remain full force and effect.

Signed and sealed this _____ day of _____ 2024

(PRINCIPAL)

(SEAL)

(WITNESS)

(TITLE)

(MAJOR OFFICER OF SURETY)

(MAJOR OFFICER OF SURETY)

(TITLE)

(TITLE)

(RESIDENT GENERAL AGENT)

INSTRUCTION TO PROVIDERS:

NOTICE to all Insurance and Bonding Institutions:

The Bond requires the signatures of the Vendor, two (2) major Officers of the Surety and Resident General Agent, if the Surety is a foreign or alien surety.

When the form is submitted to THE PORT AUTHORITY OF GUAM, it should be accompanied with copies of
The following:

1. Current Certificate of Authority to do business on Guam issued by the Department of Revenue and Taxation.
2. Power of Attorney issued by the Surety to the Resident General Agent.
3. Power of Attorney issued by two (2) major officers of the Surety to whoever is signing on their behalf.

Bonds, submitted as Bid Guarantee, without signatures and supporting documents are invalid and Bids will be rejected.

DECLARATION RE: ETHICAL STANDARDS
(AG Form 005)

_____ [state name of declarant signing below], hereby declares that:

The declarant is _____ [state one of the following: *the Bidder/Offeror, a partner of the Bidder/Offeror, an officer of the Bidder/Offeror*] making the foregoing identified bid or proposal. To the best of declarant's knowledge, neither declarant nor any officers, representatives, agents, subcontractors or employees of offeror have knowingly influenced any government of Guam employee to breach any of the ethical standards set forth in 5 GCA Chapter 5, Article 11. Further, declarant promises that neither he or she, nor any officer, representative, agent, subcontractor, or employee of bidder/offeror will knowingly influence any government of Guam employee to breach any ethical standards set forth in 5 GCA Chapter 5, Article 11. These statements are made pursuant to 5GCA §§ 5626, 5628 through 5633; and 2 GAR Division 4 § 11103(b).

I hereby declare under penalty of perjury under the laws of Guam that the foregoing is true and correct.

Signature of one of the following:

Bidder/ Offeror, if the bidder/offeror is an individual; Partner, if the bidder/offeror is a partnership; Officer, if the bidder/offeror is a corporation.

DECLARATION RE: NO GRATUITIES or KICKBACKS
(AG Form 004)

_____ [state name of declarant signing below], hereby
declare that:

1. The name of the offering firm or individual is _____ [state name
of bidder/offeror company] Declarant is _____ [state one of the
following: the bidder/offeror, a partner of the bidder/offeror, an officer of the bidder/offeror] making the
foregoing identified bid or proposal.

2. To the best of declarant's knowledge, neither declarant, nor any of the bidder's/offeror's officers,
representatives, agents, subcontractors, or employees have violated, are violating the prohibition against
gratuities and kickbacks set forth in 2 GAR Division 4 § 11107(e). Further, affiant promises, on behalf of
bidder/offeror, not to violate the prohibition against gratuities and kickbacks as set forth in 2 GAR Division 4 §
11107(e).

3. To the best of declarant's knowledge, neither declarant, nor any of the bidders/offerors officers,
representatives, agents, subcontractors, or employees have offered, given or agreed to give, any government
of Guam employee or former government employee, any payment, gift, kickback, gratuity or offer of
employment in connection with the bidders/offerors bid or proposal.

4. I make these statements on behalf of myself as a representative of the bidder/offeror, and on behalf
of the bidder/offeror's officers, representatives, agents, subcontractors, and employees.

I hereby declare under penalty of perjury under the laws of Guam that the foregoing is true and correct.

Signature of one of the following:

Offeror, if the bidder/offeror is an individual;
Partner, if the bidder/offeror is a partnership;
Officer, if the bidder/offeror is a corporation.

SPECIAL PROVISIONS

RESTRICTION AGAINST SEX OFFENDERS EMPLOYED BY SERVICES PROVIDERS TO GOVERNMENT OF GUAM FROM WORKING ON GOVERNMENT PROPERTY

If a contract for services is awarded to the bidder or offeror, then the service provider must warranty that no person in its employment who has been convicted of a sex offense under the provisions of chapter 25 of Title 9 of Guam code Annotated or of an offense defined in Article 2 of chapter 28 of Title 9 of the Guam Code annotated, or who has been convicted in any other jurisdiction of an offense with the same elements as heretofore defined, or who is listed on the Sex Offender Registry, shall provide services on behalf of the service provider while on government of Guam property, with the exception of public highways. If any employee of a service provider is providing services on government property and is convicted subsequent to an award of a contract, then the service provider warrants that it will notify the Government of the conviction within twenty-four (24) hours of the conviction, and will immediately remove such convicted person from providing services on government property. If the service provider is found to be in violation of any of the provisions of this paragraph, then the government will give notice to the service provider to take corrective action. The service provider shall take corrective action within twenty-four (24) hours of notice from the Government, and the service provider shall notify the Government when action has been taken. If the service providers fail to take corrective steps within twenty-four (24) hours of notice from the Government, then the Government in its sole discretion may suspend temporarily and contract for services until corrective action has been taken.

Signature of Bidder

Proposer, if an individual;
Partner, if a partnership;
Officer, if a corporation.

Date

DECLARATION RE COMPLIANCE WITH U.S. D.O.L. WAGE DETERMINATION

Procurement No: IFB-PAG-013-24 Re-bid 180 FT. Telescopic Boom Lift

Name of Offeror Company: _____ hereby certifies
under penalty of perjury:

(1) That I am _____ (the offeror, a partner of the offeror, an officer of the offeror) making the bid or proposal in the foregoing identified procurement;

(2) That I have read and understand the provisions of 5 GCA § 5801 and § 5802 which read:

§ 5801. Wage Determination Established.

In such cases where the government of Guam enters into contractual arrangements with a sole proprietorship, a partnership or a corporation ("contractor") for the provision of a service to the government of Guam, and in such cases where the contractor employs a person(s) whose purpose, in whole or in part, is the direct delivery of service contracted by the government of Guam, then the contractor shall pay such employee(s) in accordance with the Wage Determination for Guam and the Northern Mariana Islands issued and promulgated by the U.S. Department of Labor for such labor as is employed in the direct delivery of contract deliverables to the government of Guam.

The Wage Determination most recently issued by the U.S. Department of Labor at the time a contract is awarded to a contractor by the government of Guam shall be used to determine wages, which shall be paid to employees pursuant to this Article. Should any contract contain a renewal clause, then at the time of renewal adjustments, there shall be made stipulations contained in that contract for applying the Wage Determination, as required by this Article, so that the Wage Determination promulgated by the U.S. Department of Labor on a date most recent to the renewal date shall apply.

§ 5802. Benefits.

In addition to the Wage Determination detailed in this Article, any contract to which this Article applies shall also contain provisions mandating health and similar benefits for employees covered by this Article, such benefits having a minimum value as detailed in the Wage Determination issued and promulgated by the U.S. Department of Labor, and shall contain provisions guaranteeing a minimum of ten (10) paid holidays per annum per employee.

(3) That the offeror is in full compliance with 5 GCA § 5801 and § 5802, as may be applicable to the procurement referenced herein;

(4) That I have attached the most recent wage determination applicable to Guam issued by the U.S. Department of Labor. [INSTRUCTIONS – Please attach]

Signature

Date

**"REGISTER OF WAGE DETERMINATIONS
UNDER THE SERVICE CONTRACT ACT**
By direction of the Secretary of Labor

Daniel W. Simms, Division of
Director Wage Determinations

U.S. DEPARTMENT OF LABOR
EMPLOYMENT STANDARDS ADMINISTRATION
WAGE AND HOUR DIVISION
WASHINGTON D.C. 20210
Wage Determination No.: 2015-5693
Revision No.: 19 | Date of Last Revision: 07/17/2023

Note: Contracts subject to the Service Contract Act are generally required to pay at least the applicable minimum wage rate required under Executive Order 14026, if the contract is entered into on or after January 30 2022 or the contract is renewed or extended (e.g., an option is exercised) on or after January 30 2022. The contractor must pay all covered workers at least \$16.20 per hour (or the applicable wage rate listed on this wage determination if it is higher) for all hours spent performing on the contract in 2023.

The applicable Executive Order minimum wage rate will be adjusted annually. Additional information on contractor requirements and worker protections under the Executive Orders is available at <https://www.dol.gov/agencies/whd/government-contracts>.

States: Guam Northern Marianas Wake Island
Area: Guam Statewide
Northern Marianas Statewide
Wake Island Statewide

Fringe Benefits Required Follow the Occupational Listing

OCCUPATION CODE - TITLE	FOOTNOTE RATE	OCCUPATION CODE - TITLE	FOOTNOTE RATE
-------------------------	---------------	-------------------------	---------------

01000 - Administrative Support And Clerical Occupations

01011 - Accounting Clerk I	14.27***
01012 - Accounting Clerk II	16.02***
01013 - Accounting Clerk III	17.93
01020 - Administrative Assistant	21.43
01035 - Court Reporter	17.40
01041 - Customer Service Representative I	12.75***
01042 - Customer Service Representative II	14.28***
01043 - Customer Service Representative III	15.62***
01051 - Data Entry Operator I	12.16***
01052 - Data Entry Operator II	13.27***
01060 - Dispatcher, Motor Vehicle	17.39
01070 - Document Preparation Clerk	13.85***
01090 - Duplicating Machine Operator	13.85***
01111 - General Clerk I	11.33***
01112 - General Clerk II	12.36***
01113 - General Clerk III	13.88***
01120 - Housing Referral Assistant	19.39
01141 - Messenger Courier	11.37***
01191 - Order Clerk I	12.57***
01192 - Order Clerk II	13.71***
01261 - Personnel Assistant (Employment) I	15.95***
01262 - Personnel Assistant (Employment) II	17.85
01263 - Personnel Assistant (Employment) III	19.89
01270 - Production Control Clerk	22.97
01290 - Rental Clerk	11.10***
01300 - Scheduler, Maintenance	15.55***
01311 - Secretary I	15.55***
01312 - Secretary II	17.40
01313 - Secretary III	19.39
01320 - Service Order Dispatcher	15.40***
01410 - Supply Technician	21.43
01420 - Survey Worker	16.96
01460 - Switchboard Operator/Receptionist	10.78***
01531 - Travel Clerk I	13.01***
01532 - Travel Clerk II	14.12***
01533 - Travel Clerk III	15.09***
01611 - Word Processor I	14.53***
01613 - Word Processor III	18.26
05000 - Automotive Service Occupations	
05005 - Automobile Body Repairer, Fiberglass	17.20
05010 - Automotive Electrician	16.16***
05040 - Automotive Glass Installer	15.13***
05070 - Automotive Worker	15.11***
05110 - Mobile Equipment Servicer	12.96***
05130 - Motor Equipment Metal Mechanic	17.20
05160 - Motor Equipment Metal Worker	15.11***
05190 - Motor Vehicle Mechanic	17.20
05220 - Motor Vehicle Mechanic Helper	11.87***
05250 - Motor Vehicle Upholstery Worker	14.06***
05280 - Motor Vehicle Wrecker	15.11***
05310 - Painter, Automotive	16.16***
05340 - Radiator Repair Specialist	15.11***
05370 - Tire Repairer	12.67***
05400 - Transmission Repair Specialist	17.20
07000 - Food Preparation And Service Occupations	
07010 - Baker	11.10***
07041 - Cook I	14.44***
07042 - Cook II	16.81
07070 - Dishwasher	9.69***
07130 - Food Service Worker	10.11***
07210 - Meat Cutter	13.34***
07260 - Water/Waitress	9.73***

09000 - Furniture Maintenance And Repair Occupations

09010 - Electrostatic Spray Painter	18.75
09040 - Furniture Handler	11.37***
09080 - Furniture Refinisher	18.75
09090 - Furniture Refinisher Helper	13.77***
09110 - Furniture Repairer, Mi	16.32
09130 - Upholsterer	18.75
11000 - General Services And Support Occupations	
11030 - Cleaner, Vehicles	9.69***
11060 - Elevator Operator	9.69***
11090 - Gardener	14.28***
11122 - Housekeeping Aide	10.13***
11150 - Janitor	10.13***
11210 - Laborer, Grounds Maintenance	10.79***
11240 - Maid or Houseman	9.67***
11260 - Pruner	9.65***
11270 - Tractor Operator	13.07***
11390 - Trail Maintenance Worker	10.79***
01612 - Word Processor II	16.31
11360 - Window Cleaner	11.32***
12000 - Health Occupations	
12010 - Ambulance Driver	18.96
12011 - Breath Alcohol Technician	18.96
12012 - Certified Occupational Therapist Assistant	26.02
12015 - Certified Physical Therapist Assistant	26.02
12020 - Dental Assistant	18.79
12025 - Dental Hygienist	39.73
12030 - EKG Technician	28.73
12035 - Electroneurodiagnostic Technologist	28.73
12040 - Emergency Medical Technician	18.96
12071 - Licensed Practical Nurse I	16.95
12072 - Licensed Practical Nurse II	18.96
12073 - Licensed Practical Nurse III	21.14
12100 - Medical Assistant	13.42***
12130 - Medical Laboratory Technician	18.82
12160 - Medical Record Clerk	14.97***
12190 - Medical Record Technician	17.77
12195 - Medical Transcriptionist	16.95
12210 - Nuclear Medicine Technologist	41.68
12221 - Nursing Assistant I	12.43***
12222 - Nursing Assistant II	13.97***
12223 - Nursing Assistant III	15.24***
12224 - Nursing Assistant IV	17.12
12235 - Optical Dispenser	18.96
12236 - Optical Technician	16.95
12250 - Pharmacy Technician	15.49***
12280 - Phlebotomist	16.95
12305 - Radiologic Technologist	28.73
12311 - Registered Nurse I	23.50
12312 - Registered Nurse II	28.73
12313 - Registered Nurse II, Specialist	28.73
12314 - Registered Nurse III	34.76
12315 - Registered Nurse III, Anesthetist	34.76
12316 - Registered Nurse IV	41.68
12317 - Scheduler (Drug and Alcohol Testing)	23.50
12320 - Substance Abuse Treatment Counselor	23.50
13000 - Information And Arts Occupations	
13011 - Exhibits Specialist I	21.42
13012 - Exhibits Specialist II	26.53
13013 - Exhibits Specialist III	32.45
13041 - Illustrator I	21.42
13042 - Illustrator II	26.53
13043 - Illustrator III	32.45

OCCUPATION CODE - TITLE	FOOTNOTE RATE	FOOTNOTE
13047 Librarian	29.38	
13050 - Library Aide/Clerk	17.05	
13054 - Library Information Technology Systems Administrator	26.53	
13058 Library Technician	18.11	
13061 - Media Specialist I	19.15	
13062 - Media Specialist II	21.42	
13063 - Media Specialist III	23.87	
13071 - Photographer I	19.15	
13072 - Photographer II	21.42	
13073 - Photographer III	26.53	
13074 - Photographer IV	32.45	
13075 - Photographer V	39.27	
13090 - Technical Order Library Clerk	21.42	
13110 - Video Teleconference Technician	19.15	
14000 - Information Technology Occupations		
14041 - Computer Operator I	15.71***	
14042 - Computer Operator II	17.22	
14043 - Computer Operator III	19.19	
14044 - Computer Operator IV	21.33	
14045 - Computer Operator V	23.62	
14071 - Computer Programmer I (see 1)	15.73***	
14072 - Computer Programmer II (see 1)	19.50	
14073 - Computer Programmer III (see 1)	23.84	
14074 - Computer Programmer IV (see 1)	24.23	
14101 - Computer Systems Analyst I (see 1)	24.23	
14102 - Computer Systems Analyst II (see 1)	24.23	
14103 - Computer Systems Analyst III (see 1)	24.23	
14150 - Peripheral Equipment Operator	15.71***	
14160 - Personal Computer Support Technician	21.33	
14170 - System Support Specialist	21.24	
15000 - Instructional Occupations		
15010 - Aircrew Training Devices Instructor (Non-Rated)	24.23	
15020 - Aircrew Training Devices Instructor (Rated)	29.32	
15030 - Air Crew Training Devices Instructor (Pilot)	34.91	
15050 - Computer Based Training Specialist / Instructor	24.23	
15060 - Educational Technologist	29.40	
15070 - Flight Instructor (Pilot)	34.91	
15080 - Graphic Artist	20.47	
15085 - Maintenance Test Pilot, Fixed, Jet/Prop	34.91	
15086 - Maintenance Test Pilot, Rotary Wing	34.91	
15088 - Non-Maintenance Test/Co-Pilot	34.91	
15090 - Technical Instructor	17.67	
15095 - Technical Instructor/Course Developer	23.78	
15110 - Test Proctor	15.70**	
15120 - Tutor	15.70**	
16000 - Laundry, Dry-Cleaning, Pressing And Related Occupations		
16010 - Assembler	10.83***	
16030 - Counter Attendant	10.83***	
16040 - Dry Cleaner	12.36***	
16070 - Finisher, Flatwork, Machine	10.83***	
16090 - Presser, Hand	10.83***	
16110 - Presser, Machine, Drycleaning	10.83***	
16130 - Presser, Machine, Shirts	10.83***	
16160 - Presser, Machine, Wearing Apparel, Laundry	12.88***	
16190 - Sewing Machine Operator	13.40***	
16220 - Taker	11.34***	
16250 - Washer, Machine	11.34***	
19000 - Machine Tool Operation And Repair Occupations		
19010 - Machine-Tool Operator (Tool Room)	19.46	
19040 - Tool And Die Maker	24.46	
21000 - Materials Handling And Packing Occupations		
21020 - Forklift Operator	15.36***	
21030 - Material Coordinator	22.97	
21040 - Material Expediter	22.97	
21050 - Material Handling Laborer	12.57***	
21071 - Order Filler	10.62***	
21080 - Production Line Worker (Food Processing)	15.36***	
21110 - Shipping Packer	17.12	
21130 - Shipping/Receiving Clerk	17.12	
21140 - Store Worker I	15.83***	
21150 - Stock Clerk	22.26	
21210 - Tools And Parts Attendant	15.36***	
21410 - Warehouse Specialist	15.36***	
23000 - Mechanics And Maintenance And Repair Occupations		
23010 - Aerospace Structural Welder	25.04	
23019 - Aircraft Logs And Records Technician	19.47	
23021 - Aircraft Mechanic I	23.84	
23022 - Aircraft Mechanic II	25.04	
23023 - Aircraft Mechanic III	26.30	
23040 - Aircraft Mechanic Helper	16.58	
23050 - Aircraft Painter	22.39	
23060 - Aircraft Servicer	19.47	
23070 - Aircraft Survival Flight Equipment Technician	22.39	
23080 - Aircraft Worker	21.03	
23091 - Aircrew Life Support Equipment (ALSE) Mechanic I	21.03	
23092 - Aircrew Life Support Equipment (ALSE) Mechanic II	23.84	

OCCUPATION CODE - TITLE FOOTNOTE RATE

OCCUPATION CODE - TITLE	FOOTNOTE RATE	RAT
23110 - Appliance Mechanic	19.46	
23120 - Bicycle Repairer	15.61***	
23125 - Cable Splicer	22.47	
23130 - Carpenter, Maintenance	17.58	
23140 - Carpet Layer	18.20	
23160 - Electrician, Maintenance	19.37	
23181 - Electronics Technician Maintenance I	18.20	
23182 - Electronics Technician Maintenance II	19.46	
23183 - Electronics Technician Maintenance III	20.72	
23260 - Fabric Worker	16.94	
23290 - Fire Alarm System Mechanic	16.77	
23310 - Fire Extinguisher Repairer	15.61***	
23311 - Fuel Distribution System Mechanic	20.72	
23312 - Fuel Distribution System Operator	15.61***	
23370 - General Maintenance Worker	19.24***	
23380 - Ground Support Equipment Mechanic	23.84	
23381 - Ground Support Equipment Servicer	19.47	
23382 - Ground Support Equipment Worker	21.03	
23391 - Gunsmith I	15.61***	
23392 - Gunsmith II	18.20	
23393 - Gunsmith III	20.72	
23410 - Heating, Ventilation And Air-Conditioning Mechanic	19.27	
23411 - Heating, Ventilation And Air Conditioning Mechanic (Research Facility)	20.50	
23430 - Heavy Equipment Mechanic	19.50	
23440 - Heavy Equipment Operator	18.10	
23460 - Instrument Mechanic	20.72	
23465 - Laboratory/Shelter Mechanic	19.46	
23470 - Laborer	12.57***	
23510 - Locksmith	19.46	
23530 - Machinery Maintenance Mechanic	23.13	
23550 - Machinist, Maintenance	20.72	
23580 - Maintenance Trades Helper	11.77***	
23591 - Metrology Technician I	20.72	
23592 - Metrology Technician II	22.03	
23593 - Metrology Technician III	23.33	
23640 - Millwright	20.72	
23710 - Office Appliance Repairer	18.46	
23760 - Painter, Maintenance	17.04	
23790 - Pipefitter, Maintenance	19.56	
23810 - Plumber, Maintenance	18.75	
23820 - Pneumatic Systems Mechanic	20.72	
23850 - Rigger	20.72	
23870 - Scale Mechanic	18.20	
23890 - Sheet-Metal Worker, Maintenance	19.55	
23910 - Small Engine Mechanic	18.20	
23931 - Telecommunications Mechanic I	19.96	
23932 - Telecommunications Mechanic II	21.24	
23950 - Telephone Lineman	20.62	
23960 - Welder, Combination, Maintenance	19.96	
23965 - Welder Driller	20.72	
23970 - Woodcraft Worker	21.13	
23980 - Woodworker	15.61***	
24000 - Personal Needs Occupations		
24550 - Case Manager	15.01***	
24570 - Child Care Attendant	10.09***	
24580 - Child Care Center Clerk	13.25***	
24610 - Chore Aide	14.06***	
24620 - Family Readiness And Support Services Coordinator	15.01***	
24630 - Homemaker	16.12***	
25000 - Plant And System Operations Occupations		
25010 - Boiler Tender	22.79	
25040 - Sewage Plant Operator	22.89	
25070 - Stationary Engineer	22.79	
25290 - Ventilation Equipment Tender	15.72***	
25210 - Water Treatment Plant Operator	22.89	
27000 - Protective Service Occupations		
27004 - Alarm Monitor	10.90***	
27007 - Baggage Inspector	9.63***	
27008 - Corrections Officer	14.59***	
27010 - Court Security Officer	14.59***	
27010 - Court Security Officer	10.90***	
27030 - Detection Dog Handler	14.59***	
27040 - Detention Officer	14.59***	
27070 - Firefighter	9.63***	
27101 - Guard I	10.90***	
27102 - Guard II	14.59***	
27131 - Police Officer I	16.21	
27132 - Police Officer II	16.21	
28000 - Recreation Occupations		
28041 - Carnival Equipment Operator	13.24***	
28042 - Carnival Equipment Repairer	14.45***	
28043 - Carnival Worker	9.78***	
28210 - Gate Attendant/Gate Tender	13.18***	

OCCUPATION CODE - TITLE FOOTNOTE RATE

28310 - Lifeguard	11.01***		99000 - Miscellaneous Occupations	16.14***
28350 - Park Attendant (Aide)	14.74***		99020 - Cabin Safety Specialist	10.01***
28510 - Recreation Aide/Health Facility Attendant	11.84***		99030 - Cashier	9.71***
28515 - Recreation Specialist	18.26		99050 - Desk Clerk	27.37
29000 - Stevedoring/Longshoremen Occupational Services			99095 - Embalmer	27.37
29010 - Stevedore And Bracer	26.02		99130 - Flight Follower	
29020 - Hatch Tender	26.02		99251 - Laboratory Animal Caretaker I	
29030 - Line Handler	26.02		24.31	
29041 - Stevedore I	24.21		99252 - Laboratory Animal Caretaker II	
29042 - Stevedore II	27.82		26.56	
30000 - Technical Occupations			99260 - Marketing Analyst	21.54
30010 - Air Traffic Control Specialist, Center (HFO) (see 2)	43.06		99310 - Mortician	27.37
30011 - Air Traffic Control Specialist, Station (HFO) (see 2)	29.69		99410 - Pest Controller	16.07***
30012 - Air Traffic Control Specialist, Terminal (HFO) (see 2)	32.70		99510 - Photofinishing Worker	
30021 - Archeological Technician I	18.17		14.38***	
30022 - Archeological Technician II	20.33		99710 - Recycling Laborer	
30023 - Archeological Technician III	25.19		17.32	
30030 - Cartographic Technician	25.19		99711 - Recycling Specialist	
30040 - Civil Engineering Technician	25.19		23.38	
30051 - Cryogenic Technician I	27.89		99730 - Refuse Collector	16.40
30052 - Cryogenic Technician II	30.80		99810 - Sales Clerk	10.63***
30061 - Drafter/CAD Operator I	18.17		99820 - School Crossing Guard	17.96
30062 - Drafter/CAD Operator II	20.33		99830 - Survey Party Chief	21.99
30063 - Drafter/CAD Operator III	22.56		99831 - Surveying Aide	13.65***
30064 - Drafter/CAD Operator IV	27.89		99832 - Surveying Technician	17.73
30081 - Engineering Technician I	16.19***		99840 - Vending Machine Attendant	24.31
30082 - Engineering Technician II	18.17		99041 - Vending Machine Repairer	30.96
30083 - Engineering Technician III	20.33			
30084 - Engineering Technician IV	25.19			
30085 - Engineering Technician V	30.80			
30086 - Engineering Technician VI	37.27			
30090 - Environmental Technician	25.19			
30095 - Evidence Control Specialist	22.66			
30210 - Laboratory Technician	27.89			
30221 - Latent Fingerprint Technician I	30.80			
30222 - Latent Fingerprint Technician II	25.19			
30740 - Mathematical Technician	19.54			
30361 - Paralegal/Legal Assistant I	24.21			
30362 - Paralegal/Legal Assistant II	29.61			
30363 - Paralegal/Legal Assistant III	35.83			
30364 - Paralegal/Legal Assistant IV	30.80			
30375 - Petroleum Supply Specialist	24.82			
30390 - Photo-Optics Technician	30.80			
30395 - Radiation Control Technician	25.19			
30461 - Technical Writer I	30.80			
30462 - Technical Writer II	37.27			
30463 - Technical Writer III	27.37			
30481 - Unexploded Ordnance (UXO) Technician I	33.11			
30492 - Unexploded Ordnance (UXO) Technician II	39.69			
30493 - Unexploded Ordnance (UXO) Technician III	27.37			
30494 - Unexploded (UXO) Safety Escort	27.37			
30495 - Unexploded (UXO) Sweep Personnel	27.89			
30501 - Weather Forecaster I	33.93			
30502 - Weather Forecaster II	(see 2) 22.66			
30620 - Weather Observer, Combined Upper Air Or Surface Programs	25.19			
30621 - Weather Observer, Senior (see 2)	35.11			
31000 - Transportation/Mobile Equipment Operation Occupations				
31010 - Airplane Pilot	8.97***			
31020 - Bus Aide	11.73***			
31030 - Bus Driver	10.26***			
31043 - Driver Courier	9.91***			
31260 - Parking and Lot Attendant	11.65***			
31290 - Shuttle Bus Driver	11.41***			
31310 - Taxi Driver	12.21***			
31361 - Truckdriver, Light	12.16***			
31362 - Truckdriver, Medium	16.11***			
31363 - Truckdriver, Heavy	16.11***			
31364 - Truckdriver, Tractor-Trailer				

***Workers in this classification may be entitled to a higher minimum wage under Executive Order 14026 (\$16.20 per hour). Please see the Note at the top of the wage determination for more information. Please also note that the minimum wage requirements of Executive Order 14026 are not currently being enforced as to contracts or contract-like instruments entered into with the federal government in connection with seasonal recreational services or seasonal recreational equipment rental for the general public on federal lands.

ALL OCCUPATIONS LISTED ABOVE RECEIVE THE FOLLOWING BENEFITS:

HEALTH & WELFARE: \$4.98 per hour, up to 40 hours per week, or \$199.20 per week or \$863.20 per month

HEALTH & WELFARE EO 13706: \$4.57 per hour, up to 40 hours per week, or \$182.80 per week, or \$797.33 per month*

*This rate is to be used only when compensating employees for performance on an SCA-covered contract also covered by EO 13706. Establishing Paid Sick Leave for Federal Contractors. A contractor may not receive credit toward its SCA obligations for any paid sick leave provided pursuant to EO 13706.

VACATION: 2 weeks paid vacation after 1 year of service with a contractor or successor; and 4 weeks after 3 years. Length of service includes the whole span of continuous service with the present contractor or successor, wherever employed, and with the predecessor contractors in the performance of similar work at the same Federal facility. (Reg. 29 CFR 4.173) HOLIDAYS: A minimum of eleven paid holidays per year: New Year's Day, Martin Luther King Jr.'s Birthday, Washington's Birthday, Memorial Day, Juneteenth National Independence Day, Independence Day, Labor Day, Columbus Day, Veterans' Day, Thanksgiving Day, and Christmas Day. [A contractor may substitute for any of the named holidays another day off with pay in accordance with a plan communicated to the employees involved.] (See 29 CFR 4.174)

THE OCCUPATIONS WHICH HAVE NUMBERED FOOTNOTES IN PARENTHESES RECEIVE THE FOLLOWING:

1) **COMPUTER EMPLOYEES:** This wage determination does not apply to any individual employed in a bona fide executive, administrative, or professional capacity, as defined in 29 C.F.R. Part 541, (See 43 C.F.R. 6701(3)). Because most Computer Systems Analysts and Computer Programmers who are paid at least \$27.63 per hour (or at least \$684 per week if paid on a salary or fee basis) likely qualify as exempt computer professionals under 29 U.S.C. 213(a)(1) and 29 U.S.C. 213(a)(17), this wage determination may not include wage rates for all occupations within those job families. In such instances, a conformance will be necessary if there are nonexempt employees in these job families working on the contract.

Job titles vary widely and change quickly in the computer industry, and are not determinative of whether an employee is an exempt computer professional. To be exempt, computer employees who satisfy the compensation requirements must also have a primary duty that consists of:

- (1) The application of systems analysis techniques and procedures, including consulting with users, to determine hardware, software or system functional specifications;
- (2) The design, development, documentation, analysis, creation, testing or modification of computer systems or programs, including prototypes, based on and related to user or system design specifications;
- (3) The design, documentation, testing, creation or modification of computer programs related to machine operating systems; or
- (4) A combination of the aforementioned duties, the performance of which requires the same level of skills. (29 C.F.R. 541.400)

Any computer employee who meets the applicable compensation requirements and the above duties test qualifies as an exempt computer professional under both section 13(a)(1) and section 13(a)(17) of the Fair Labor Standards Act. (Field Assistance Bulletin No. 2006-3 (Dec. 14, 2006)). Accordingly, this wage determination will not apply to any exempt computer employee, regardless of which of these two exemptions is utilized.

2) **AIR TRAFFIC CONTROLLERS AND WEATHER OBSERVERS - NIGHT PAY & SUNDAY PAY:** If you work at night as part of a regular tour of duty, you will earn a night differential and receive an additional 10% of basic pay for any hours worked between 6pm and 6am. If you are a full-time employed (40 hours a week) and Sunday is part of your regularly scheduled workweek, you are paid at your rate of basic pay plus a Sunday premium of 25% of your basic rate for each hour of Sunday work which is not overtime (i.e.: occasional work on Sunday outside the normal tour of duty is considered overtime work).

**** HAZARDOUS PAY DIFFERENTIAL ****

An 8 percent differential is applicable to employees employed in a position that represents a high degree of hazard when working with or in close proximity to ordnance, explosives, and incendiary materials. This includes work such as screening, blending, drying, mixing, and pressing of sensitive ordnance, explosives, and pyrotechnic compositions such as lead azide, black powder and photoflash powder. All dry-house activities involving propellants or explosives. Demilitarization, modification, renovation, demolition, and maintenance operations on sensitive ordnance, explosives and incendiary materials. All operations involving re-grading and cleaning of artillery ranges.

A 4 percent differential is applicable to employees employed in a position that represents a low degree of hazard when working with, or in close proximity to ordnance, for employees possibly adjacent to explosives and incendiary materials which involves potential injury such as laceration of hands, face, or arms of the employee engaged in the operation, irritation of the skin, minor burns and the like; minimal damage to immediate or adjacent work area or equipment being used. All operations involving, unloading, storage, and hauling of ordnance, explosive, and incendiary ordnance material other than small arms ammunition. These differentials are only applicable to work that has been specifically designated by the agency for ordnance, explosives, and incendiary material differential pay.

**** UNIFORM ALLOWANCE ****

If employees are required to wear uniforms in the performance of this contract (either by the terms of the Government contract, by the employer, by the state or local law, etc.), the cost of furnishing such uniforms and maintaining (by laundering or dry cleaning) such uniforms is an expense that may not be borne by an employee where such cost reduces the hourly rate below that required by the wage determination. The Department of Labor will accept payment in accordance with the following standards as compliance:

The contractor or subcontractor is required to furnish all employees with an adequate number of uniforms without cost or to reimburse employees for the actual cost of the uniforms. In addition, where uniform cleaning and maintenance is made the responsibility of the employee, all contractors and subcontractors subject to this wage determination shall (in the absence of a bona fide collective bargaining agreement providing for a different amount, or the furnishing of contrary affirmative proof as to the actual cost), reimburse all employees for such cleaning and maintenance at a rate of \$3.35 per week (or 5.67 cents per day). However, in those instances where the uniforms furnished are made of "wash and wear" materials, may be routinely washed and dried with other personal garments, and do not require any special treatment such as dry cleaning, daily washing, or commercial laundering in order to meet the cleanliness or appearance standards set by the terms of the Government contract, by the contractor, by law, or by the nature of the work, there is no requirement that employees be reimbursed for uniform maintenance costs.

**** SERVICE CONTRACT ACT DIRECTORY OF OCCUPATIONS ****

The duties of employees under job titles listed are those described in the "Service Contract Act Directory of Occupations", Fifth Edition (Revision 1), dated September 2015, unless otherwise indicated.

**** REQUEST FOR AUTHORIZATION OF ADDITIONAL CLASSIFICATION AND WAGE RATE, Standard Form 1444 (SF-1444) ****

Conformance Process: The contracting officer shall require that any class of service employee which is not listed herein and which is to be employed under the contract (i.e., the work to be performed is not performed by any classification listed in the wage determination), be classified by the contractor so as to provide a reasonable relationship (i.e., appropriate level of skill comparison) between such unlisted classifications and the classifications listed in the wage determination (See 29 CFR 4.6(b)(2)(iii)). Such conforming procedures shall be initiated by the contractor prior to the performance of contract work by such unlisted class(es) of employees (See 29 CFR 4.6(b)(2)(iii)). The Wage and Hour Division shall make a final determination of conformed classification, wage rate, and/or fringe benefits which shall be paid to all employees performing in the classification from the first day of work on which contract work is performed by them in the classification. Failure to pay such unlisted employees the compensation agreed upon by the interested parties and/or fully determined by the Wage and Hour Division retroactive to the date such class of employees commenced contract work shall be a violation of the Act and this contract. (See 29 CFR 4.6(b)(2)(vi)). When multiple wage determinations are included in a contract, a separate SF-1444 should be prepared for each wage determination to which a class(es) is to be confirmed.

The process for preparing a conformance request is as follows:

- 1) When preparing the bid, the contractor identifies the need for a conformed occupation(s) and computes a proposed rate(s)
- 2) After contract award, the contractor prepares a written report listing in order the proposed classification title(s), a federal grade equivalency (FGE) for each proposed classification(s), job description(s), and rationale for proposed wage rate(s), including information regarding the agreement or disagreement of the authorized representative of the employees involved, or where there is no authorized representative, the employees themselves. This report should be submitted to the contracting officer no later than 30 days after such unlisted class(es) of employees performs any contract work.
- 3) The contracting officer reviews the proposed action and promptly submits a report of the action, together with the agency's recommendations and pertinent information including the position of the contractor and the employees, to the U.S. Department of Labor, Wage and Hour Division, for review (See 29 CFR 4.6(b)(2)(iii)).
- 4) Within 30 days of receipt, the Wage and Hour Division approves, modifies, or disapproves the action via transmittal to the agency contracting officer, or notifies the contracting officer that additional time will be required to process the request.
- 5) The contracting officer transmits the Wage and Hour Division's decision to the contractor.

6) Each affected employee shall be furnished by the contractor with a written copy of such determination or it shall be posted as a part of the wage determination (See 29 CFR 4.6(b)(2)(iii)).

Information required by the Regulations must be submitted on SF-1444 or bond paper.

When preparing a conformance request, the "Service Contract Act Directory of Occupations" should be used to compare Job definitions to ensure that duties requested are not performed by a classification already listed in the wage determination. Remember, it is not the Job title, but the required tasks that determine whether a class is included in an established wage determination. Conformances may not be used to artificially split, combine, or subdivide classifications listed in the wage determination (See 29 CFR 4.152(c)(1))."

DECLARATION RE: NON-COLLUSION
(AG FORM 003)

_____ [state name of declarant signing below], declares that:

1. The name of the bidding/offering company or individual is [state name of company]
_____.

2. The Bid/Proposal for the solicitation identified above is genuine and not collusive or a sham. The bidder/offeree has not colluded, conspired, connived or agreed, directly or indirectly, with any other bidder/offeree or person, to put in a sham bid/proposal or to refrain from making an offer. The bidder/offeree has not in any manner, directly or indirectly, sought by an agreement or collusion, or communication or conference, with any person to fix the proposal price of bidder/offeree or of any other bidder/offeree, or to fix any overhead, profit or cost element of said proposal price, or of that of any other bidder/offeree, or to secure any advantage against the government of Guam or any other bidder/offeree, or to secure any advantage against the government of Guam or any person interested in the proposed contract. All statements in this affidavit and in the proposal are true to the best of the knowledge of the undersigned. This statement is made pursuant to 2 GAR Division 4 § 3126(b).

3. I make this statement on behalf of myself as a representative of the bidder/offeree, and on behalf of the bidder/offeree's officers, representatives, agents, subcontractors, and employees.

I hereby declare under penalty of perjury under the laws of Guam that the foregoing is true and correct.

Signature of one of the following:

Offeror, if the bidder/offeree is an individual;
Partner, if the bidder/offeree is a partnership;
Officer, if the bidder/offeree is a corporation.

**DECLARATION DISCLOSING OWNERSHIP, INFLUENCE, COMMISSIONS
AND CONFLICTS OF INTEREST**

(Required by 5 GCA § 5233 as amended by P.L. 36-13 (4/9/2021))

Preface. As a condition of submitting a Bid/Offer/Proposal or responding to any method of source selection under Guam's Procurement Law for the purpose of entering into a contract with the government of Guam, this Affidavit requires all Bidders/Offerors/Prospective Contractors to make disclosures of ownership, influence, commissions, gratuities, kickbacks, and conflicts of interest occurring during the 365 calendar days preceding the publication of this solicitation and until award of a contract. This includes the duty to disclose any changes to the facts disclosed herein throughout the solicitation process; and if the entity submitting this Affidavit is awarded a contract, the duty to disclose any changes to the facts disclosed herein continues throughout the life of the contract, including any extensions or renewals.

A. I, the undersigned, hereby declare that I am an authorized representative of the Bidder/Offeror/Prospective Contractor and that (please check and fill out all that apply):

The Bidder/Offeror/Prospective Contractor is an individual with a business license, and all decisions are by, and all profit is for, that same individual, with principal place of business street address being:

The Bidder/Offeror/Prospective Contractor is a business or artificial person (as defined in 1 GCA § 715 or 5 GCA §§ 5030(n) or 5233(b)), and is a sole proprietorship owned entirely (100%) by _____, with principal place of business street address being:

The Bidder/Offeror/Prospective Contractor is a business or artificial person (as defined in 1 GCA § 715 or 5 GCA §§ 5030(n) or 5233(b)), and is owned by the following multiple individuals. Note: owners of more than 10% are statutorily required to be listed below, but other owners of smaller percentage are encouraged to be listed as well.

Name of Owner	Principal Place of Business Street Address	% of Interest
_____	_____	_____
_____	_____	_____
_____	_____	_____

One or more of the more-than-10% owners listed above is a business or artificial person. Any more-than-25% owners of such a business or artificial person are listed below per 5 GCA § 5233. Note: any less-than-25% owners of such a business or artificial person is encouraged to also be listed below.

Name of >10% Owner Business or Artificial Person: _____

Names of owners of the >10% Owner Business or Artificial Person ("Second Tier Owner")	Owner's Principal Place of Business Street Address	% of Interest

Name of other >10% Owner Business or Artificial Person: _____

Names of owners of the >10% Owner Business or Artificial Person ("Second Tier Owner")	Owner's Principal Place of Business Street Address	% of Interest

B. If any Second Tier Owner identified above is an artificial person, the natural or artificial owners of such Second Tier Owner who have held more than 49% of the shares or interest in the Bidder/Offeror/Prospective Contractor (Third Tier Owners) are as follows (if none, please so state):

Second Tier Owner Name _____

Name of Third Tier Owner	Principal Place of Business Street Address	% of Interest

C. If the name of no natural person has been identified as an owner, or a Second or Third Tier Owner of the Bidder/Offeror/Prospective Contractor, please identify the name, position, address, and contact information of the natural person having the authority and responsibility for the Bid/Offer/Proposal/Prospective Contract, and the name of any natural person who has the authority and power to remove and replace the designated responsible person:

Name of Natural Person	Position	Street Address of Principal Place of Business	Phone Number, Email Address, and other Contact Information

D. Further, I say that the persons who have received or are entitled to receive a commission, gratuity, contingent fee or other compensation to solicit, secure, or assist in obtaining business related to the Bid/Offer/Proposal/Prospective Contract for which this Affidavit is submitted are as follows (if none, please so state):

Name	Principal Place of Business Street Address	Amount of Compensation

E. Further, I say that the persons who have directly or indirectly participated in this solicitation and who are also employees of the government of Guam or the government of the United States, if federal funds are to be used

in the payment of the contract related to the Bid/Offer/Proposal/Prospective Contract for which this Affidavit is submitted, are as follows (if none, please so state):

Name	Principal Place of Business Street Address
_____	_____
_____	_____

F. Regardless of any ownership interest, the following individuals have the power to control the performance of the contract or to control the Bidder/Offeror/Prospective Contractor, directly or indirectly:

Name	Principal Place of Business Street Address
_____	_____
_____	_____

G. Until award of the contract, and throughout the term of any contract awarded to the Bidder/Offeror/Prospective Contractor represented herein, I agree to promptly make any disclosures not made previously and update changes in ownership, identities of owners and other required information, interests, compensation or conflicts of the persons required to be disclosed. I understand that failure to comply with this requirement shall constitute a material breach of contract.

H. I hereby declare under penalty of perjury under the laws of Guam that the foregoing is true and correct.

Executed on: _____ (date)

Signature of one of the following:
Bidder/Offeror/Prospective Contractor, if a licensed individual
Owner of sole proprietorship Bidder/Offeror/Prospective
Contractor
Partner, if the Bidder/Offeror/Prospective Contractor is a
partnership
Officer, if the Bidder/Offeror/Prospective Contractor is a
corporation

**DECLARATION RE: CONTINGENT FEES
(AG Form 007)**

_____ [state name of declarant signing below], hereby declares that:

1. The name of the bidding/offering company or individual is [state name of company]

2. As a part of the bidding/offering company's bid or proposal, to the best of my knowledge, the offering company has not retained any person or agency on a percentage, commission, or other contingent arrangement to secure this contract. This statement is made pursuant to 2 GAR Division 4 § 11108(f).

3. As a part of the bidding/offering company's bid or proposal, to the best of my knowledge, the bidding/offering company has not retained a person to solicit or secure a contract with the government of Guam upon an agreement or understanding for a commission, percentage, brokerage, or contingent fee, except for retention of bona fide employees or bona fide established commercial selling agencies for the purpose of securing business. This statement is made pursuant to 2 GAR Division 4 § 11108(f).

4. I make these statements on behalf of myself as a representative of the bidder/offeree, and on behalf of the Bidder/Offerees officers, representatives, agents, subcontractors, and employees.

I hereby declare under penalty of perjury under the laws of Guam that the foregoing is true and correct.

Signature of one of the following:

Bidder/Offeree, if the bidder/offeree is an individual; Partner, if the bidder/offeree is a partnership; Officer, if the bidder/offeree is a corporation.

GOVERNMENT OF GUAM
GENERAL TERMS AND CONDITIONS

SEALED BID SOLICITATION AND AWARD

Only those Boxes checked below are applicable to this bid.

- [X] 1. **AUTHORITY:** This solicitation is issued subject to all the provision of the Guam Procurement Act (5GCA, Chapter 5) and the Guam Procurement Regulations (copies of both are available at the Office of the Compiler of laws, Department of Law, copies available for inspection at the PORT AUTHORITY OF GUAM). It requires all parties involved in the Preparation, negotiation, performance, or administration of contracts to act in good faith.
- [X] 2. **GENERAL INTENTION:** Unless otherwise specified, It is the declared and acknowledged intention and meaning of these General Terms and conditions for the bidder to provide the Government of Guam (Government) with specified services or with materials, supplies or equipment completely assembled and ready for use.
- [X] 3. **TAXES:** Bidders are cautioned that they are subject to Guam Income Taxes as well as all other taxes on Guam Transactions. Specific information on taxes may be obtained from the Director of Revenue and Taxation.
- WITHHOLDING ASSESSMENT FEE:** All procurements of professional services are subject to a withholding assessment fee for non-resident persons or companies without a valid Guam Business License, which is equal to four percent (4%) of the total dollar value of any contract awarded for all government of Guam contracts for any professional services provided by a non-resident person or company residing outside of Guam, as a cost of doing business with the government of Guam, in accordance with 11 GCA § 71114 (P.L. 31-166).
- [X] 4. **LICENSING:** Bidders are cautioned that the Government will not consider for award any offer submitted by a bidder who has not complied with the Guam Licensing Law. Specific information on licenses may be obtained from the Director of Revenue and Taxation.
- [X] 5. **NO LOCAL PROCUREMENT PREFERENCE:** There is no geographical preference for this IFB in compliance with 2 CFR § 200.319(c) and the terms and conditions of MARAD FY2022 American Marine Highway (AMH) Grant No.: 693JF72340067; however, no specification, term, condition, or qualification of this IFB shall exclude any Offeror from consideration on the basis of Guam-only experience provided that the experience of such Offeror is otherwise responsive to the solicitation, in accordance with the requirements of 5 GCA § 5008(e).
- [X] 6. **COMPLIANCE WITH SPECIFICATIONS AND OTHER SOLICITATION REQUIREMENTS:** Bidders shall comply with all specifications and other requirements of the Solicitation.
- [] 7. **"ALL OR NONE" BIDS:** NOTE: By checking this Item, the Government is requesting all of the bid items to be bid or none at all. The Government will not award on an itemized basis.
- [X] 8. **INDEPENDENT PRICE DETERMINATION:** The bidder, upon signing the Invitation for Bid, certifies that the prices in his bid were derived at without collusion, and acknowledge that collusion and anti-competitive practices are prohibited by law. Violations will be subject to the provision of Section 5651 of that of the Guam Procurement Act. Other existing civil, criminal or administrative remedies are not impaired and may be in addition to the remedies in Section 5651 of the Government code.
- [X] 9. **BIDDER'S PRICE:** The Government will consider not more than two (2) (Basic and Alternate) item prices and the bidder shall explain fully each price if supplies, materials, equipment, and/or specified services offered comply with specifications and the products origin. Where basic or alternate bid meets the minimum required specification, cost and other factors will be considered. Failure to explain this requirement will result in rejection of the bid.
- [X] 10. **BID ENVELOPE:** Envelope shall be sealed and marked with the bidder's name, Bid number, time, date and place of Bid Opening.
- [X] 11. **BID GUARANTEE REQUIREMENT:** Bidder is required to submit a Bid Guarantee Bond or standby Irrevocable Letter of Credit or Certified Check or Cashier's Check in the same bid envelope to be held by the Government pending award. The Bid Guarantee Bond, Letter of Credit, Certified Check or Cashier's Check must be issued by any local surety or banking institution licensed to do business on Guam and made payable to the Treasury of Guam in the amount of fifteen percent (15%) of his highest total bid offer. The Bid Bond must be submitted on Government Standard Form BB-1 (copy enclosed). Personal Checks will not be accepted as Bid Guarantee. If a successful Bidder (contractor) withdraws from the bid or fails to enter into contract within the prescribed time, such Bid guarantee will be forfeited to the Government of Guam. Bids will be disqualified if not accompanied by Bid Bond, Letter of Credit, Certified Check or Cashier's check. Bidder must include in his/her bid, valid copies of a Power of Attorney from the Surety and a Certificate of Authority from the Government of Guam to show proof that the surety company named on the bond instrument is authorized by the Government of Guam and qualified to do business on Guam. For detailed information on bonding matters, contact the Department of Revenue and Taxation. Failure to submit a valid Power of Attorney and Certificate of Authority on the surety is cause for rejection of bid. Pursuant to 5 GCA § 5212, all competitive sealed bidding for the procurement of supplies or services exceeding \$25,000.00 a 15% Bid Security of the total bid price must accompany the bid package. The bid bond, Letter of Credit, Certified Check or Cashier's Check will serve as Bid Security for this procurement. No award shall be given until bid security is confirmed.
- [X] 12. **PERFORMANCE GUARANTEE:** Bidders who are awarded a contract under this solicitation, guarantee that goods will be delivered or required services performed within the time specified. Failure to perform the contract in a satisfactory manner may be cause for suspension or debarment from doing business with the Government of Guam. In addition, the Government will hold the Vendor liable and will enforce the requirements as set forth in Section 40 of these General Terms and Conditions.
- [X] 13. **SURETY BONDS:** Bid and bid bonds coverage must be signed or countersigned in Guam by a foreign or alien surety's resident general agent. The surety must be an Insurance Company, authorized by the government of Guam and qualified to do business in Guam. Bids will be disqualified if the Surety Company does not have a valid Certificate of Authority from the Government of Guam to conduct business in Guam.
- [X] 14. **COMPETENCY OF BIDDERS:** Bids will be considered only from such bidders who, in the opinion of the Government, can show evidence of their ability, experience, equipment, and facilities to render satisfactory service.
- [X] 15. **DETERMINATION OF RESPONSIBILITY OF BIDDERS:** The GENERAL MANAGER reserves the right for securing from Bidders information to determine whether or not they are responsible and to inspect plant site, place of business; and supplies and services as necessary to determine their responsibility in accordance with Section 15 of these General Terms and Conditions.
(2 GAR, Div. 4 § 3116)

- [X] 16. **STANDARD FOR DETERMINATION OF LOWEST RESPONSIBLE BIDDER:**
In determining the lowest responsible offer, the GENERAL MANAGER shall be guided by the following:
- a) Price of items offered.
 - b) The ability, capacity, and skill of the Bidder to perform.
 - c) Whether the Bidder can perform promptly or within the specified time.
 - d) The quality of performance of the Bidder with regards to awards previously made to him.
 - e) The previous and existing compliance by the Bidder with laws and regulations relative to procurement.
 - f) The sufficiency of the financial resources and ability of the Bidder to perform.
 - g) The ability of the bidder to provide future maintenance and services for the subject of the award.
 - h) The compliance with all of the conditions to the Solicitation.
- [X] 17. **TIE BIDS:** If the bids are for the same unit price or total amount in the whole or in part, the GENERAL MANAGER will determine award based on 2 GAR, Div. 4, § 3109(a) (2) or to reject all such bids.
- [X] 18. **BRAND NAMES:** Any reference in the Solicitation to manufacturer's Brand Names and number is due to lack of a satisfactory specification of commodity description. Such preference is intended to be descriptive, but not restrictive and for the sole purpose of indicating prospective bidders a description of the article or services that will be satisfactory. Bids on comparable items will be considered provided the bidder clearly states in his bid the exact articles he is offering and how it differs from the original specification.
- [X] 19. **DESCRIPTIVE LITERATURE:** Descriptive literature(s) as specified in this solicitation must be furnished as a part of the bid and must be received at the date and time set for opening Bids. The literature furnished must clearly identify the item(s) in the Bid. The descriptive literature is required to establish, for the purpose of evaluation and award, details of the product(s) the bidder proposes to furnish including design, materials, components, performance characteristics, methods of manufacture, construction, assembly or other characteristics which are considered appropriate. Rejection of the Bid will be required if the descriptive literature(s) do not show that the product(s) offered conform(s) to the specifications and other requirements of this solicitation. Failure to furnish the descriptive literature(s) by the time specified in the Solicitation will require rejection of the bid.
- [] 20. **SAMPLES:** Sample(s) of item(s) as specified in this solicitation must be furnished as a part of the bid and must be received at the date and time set for opening Bids. The sample(s) should represent exactly what the bidder proposes to furnish and will be used to determine if the item(s) offered complies with the specifications. Rejection of the Bid will be required if the sample(s) do not show that the product(s) offered conform(s) to the specifications and other requirements of this solicitation. Failure to furnish the sample(s) by the time specified in the Solicitation will require rejection of the Bid.
- [] 21. **LABORATORY TEST:** Successful bidder is required to accompany delivery of his goods with a Laboratory Test Report indicating that the product he is furnishing the Government meets with the specifications. This report is on the bidder's account and must be from a certified Testing Association.
- [X] 22. **AWARD, CANCELLATION, & REJECTION:** Award shall be made to the lowest responsible and responsive bidder, whose bid is determined to be the most advantageous to the Government, taking into consideration the evaluation factors set forth in this solicitation. No other factors or criteria shall be used in the evaluation. The right is reserved as the interest of the Government may require to waive any minor irregularity in bid received. The GENERAL MANAGER shall have the authority to award, cancel, or reject bids, in whole or in part for any one or more items if he determines it is in the public interest. Award issued to the lowest responsible bidder within the specified time for the acceptance as indicated in the solicitation, results in a bidding contract without further action by either party. In case of an error in the extension of prices, unit price will govern. It is the policy of the Government to award contracts to qualified local bidders. The Government reserves the right to increase or decrease the quantity of the items for award and make additional awards for the same type items and the vendor agrees to such modifications and additional awards based on the bid prices for a period of thirty (30) days after original award. No award shall be made under this solicitation which shall require advance payment or irrevocable letter of credit from the government (2 GAR, Div.4 §1103).
- [] 23. **MARKING:** Each outside container shall be marked with the Purchase Order number, item number, brief item description and quantity. Letter marking shall not be less than 3/4" in height.
- [X] 24. **SCHEDULE FOR DELIVERY:** Successful bidder shall notify the PORT AUTHORITY OF GUAM, Telephone Nos. 477-5931, at least twenty-four (24) hours before delivery of any item under this solicitation.
- [] 25. **BILL OF SALE:** Successful supplier shall render Bills of Sale for each item delivered under this contract. Failure to comply with this requirement will result in rejection of delivery. The Bill of Sale must accompany the items delivered but will not be considered as an invoice for payment. Supplier shall bill the Government in accordance with billing instructions as indicated on the Purchase Order.
- [X] 26. **MANUFACTURER'S CERTIFICATE:** Successful bidder is required, upon delivery of any item under this contract, to furnish a certificate from the manufacturer indicating that the goods meet the specifications. Failure to comply with this request will result in rejection of delivery payment. Supplier shall bill the Government in accordance with billing instructions as indicated on the Purchase Order.
- [X] 27. **INSPECTION:** All supplies, materials, equipment, or services delivered under this contract shall be subject to the inspection and/or test conducted by the Government at destination. If in any case the supplies, materials, equipment, or services are found to be defective in material, workmanship, performance, or otherwise do not conform with the specifications, the Government shall have the right to reject the items or require that they be corrected. The number of days required for correction will be determined by the Government.
- [] 28. **MOTOR VEHICLE SAFETY REQUIREMENTS:** The Government will only consider Bids on motor vehicles which comply with the requirements of the National Traffic and Motor Vehicle safety Act of 1966 (Public Law 89-563) and Clean Air Act as amended (Public Law 88-206), that are applicable to Guam. Bidders shall state if the equipment offered comply with these aforementioned Federal Laws.
- [] 29. **SAFETY INSPECTION:** All motor vehicles delivered under this contract must pass the Government of Guam Vehicle Inspection before delivery at destination.
- [X] 30. **GUARANTEE:**
a) Guarantee of Vehicle Type of Equipment:

The successful bidder shall guarantee vehicular type of equipment offered against defective parts, workmanship, and performance, for a period of not less than one (1) year after date of receipt of equipment. Bidder shall also provide service to the equipment for at least one (1) year. Service to be provided shall include, but will not be limited to tune ups (change of spark plugs, contact points and condensers) and lubrication (change of engine and transmission oil). All parts and labor shall be at the expense of the bidder. All parts found defective and not caused by misuse, negligence or accident within the guarantee period shall be repaired, replaced, or adjusted within six (6) working days after notice from the Government and without cost to the Government. Vehicular type of equipment as used in this context shall include equipment used for transportation as differentiated from tractors, backhoes, etc.

b) Guarantee of Other Type of Equipment:

The successful bidder shall guarantee all other types of equipment offered, except those mentioned in 30a, above, against defective parts, workmanship, and performance for a period of not less than three (3) months after date of receipt of equipment. Bidder shall also provide service to the equipment for at least three (3) months. All parts found defective within that period shall be repaired or replaced by the Contractor without cost to the Government. Repairs, adjustments or replacements of defective parts shall be completed by the contractor within six (6) working days after notice from the Government.

(c) Compliance with this Section is a condition of this Bid.

- [X] 31. **REPRESENTATION REGARDING ETHICS IN PUBLIC PROCUREMENT:** The bidder or contractor represents that it has not knowingly influenced and promises that it will not knowingly influence a Government employee to breach any of the ethical standards and represents that it has not violated, is not violating, and promises that it will not violate the prohibition against gratuities and kickbacks set forth on Chapter 11 (Ethics in Public Contracting) of the Guam Procurement Act and in Chapter 11 of the Guam Procurement Regulations.
- [X] 32. **REPRESENTATION REGARDING CONTINGENT FEES:** The contractor represents that it has not retained a person to solicit or secure a Government contract upon an agreement or understanding for a commission, percentage, brokerage, or contingent fee, except for retention of bona fide employees or bona fide established commercial selling agencies for the purpose of securing business (GPR Section 11-207).
- [X] 33. **EQUAL EMPLOYMENT OPPORTUNITY:** Contractors shall not discriminate against any employee or applicant of employment because of race, color, religion, sex, or national origin. The contractor will take affirmative action to ensure that employees are treated equally during employment without regards to their race, color, religion, sex, or national origin.
- [X] 34. **COMPLIANCE WITH LAWS:** Bidders awarded a contract under this Solicitation shall comply with the applicable standard, provisions, and stipulations of all pertinent Federal and/or local laws, rules, and regulations relative to the performance of this contract and the furnishing of goods.
- [X] 35. **CHANGE ORDER:** Any order issued relative to awards made under this solicitation will be subject to and in accordance with the provisions of Section 6-101-03.1 of the Guam Procurement Regulations.
- [X] 36. **STOP WORK ORDER:** Any stop work order issued relative to awards made under this solicitation will be subject to and in accordance with the provisions of Section 6-101-04.1 of the Guam Procurement Regulations.
- [X] 37. **CANCELLATION OF INVITATION FOR BIDS OR REQUEST FOR PROPOSALS:** Any Invitation for Bid may be cancelled, or any or all bids or proposals may be rejected in whole or in part as may be specified in the solicitation, when it is in the best interests of the Territory in accordance with regulations promulgated by the Policy Office. The reasons therefor shall be made part of the contract file.
- [X] 38. **TIME FOR COMPLETION:** It is hereby understood and mutually agreed by and between the contractor and the Government that the time for delivery to final destination or the timely performance of certain services is an essential condition of this contract. If the contractor refuses or fails to perform any of the provisions of this contract within the time specified in the Purchase Order (from the date Purchase Order is acknowledged by vendor), then the contractor is in default. Defaults will be treated subject to and in accordance with the provisions of 2 GAR, Div. 4 § 6101(8)
- [X] 39. **JUSTIFICATION OF DELAY:** Bidders who are awarded contracts under this Solicitation, guarantee that the goods will be delivered to their destination or required services rendered within the time specified. If the bidder is not able to meet the specified delivery date, he is required to notify the GENERAL MANAGER of such delay. Notification shall be in writing and shall be received by the GENERAL MANAGER at least twenty-four (24) hours before the specified delivery date. Notification of delay shall include an explanation of the causes and reasons for the delay including statement(s) from supplier or shipping company causing the delay. The Government reserves the right to reject delay justification if, in the opinion of the GENERAL MANAGER, such justification is not adequate.
- [X] 40. **SERVICE-DISABLED VETERAN OWNED BUSINESS PREFERENCE:** Bidding is subject to the policy in favor of Service-Disabled Veteran Owned Business as defined in 5 GCA sections 5011 and 5012.
- [X] 41. **LIQUIDATED DAMAGES:** When the contractor is given notice of delay or nonperformance as specified in Paragraph 1 (Default) of the Termination for Default Clause of this contract and fails to cure in the time specified, the contractor shall be liable for damages for delay in the amount of one-fourth of one percent (1%) of outstanding order per calendar day from date set for cure until either the territory reasonable obtains similar supplies or services if the contractor is terminated for default, or until the contractor provides the supplies or services if the contractor is not terminated for default. To the extent that the contractor's delay or nonperformance is excused under Paragraph 40 [Excuse for Nonperformance or Delayed Performance] of the Termination for Default Clause of this contract, liquidated damages shall not be due the territory. The contractor remains liable for damages caused other than by delay. 2 GAR, Div. 4 §6101(d).
- [X] 42. **PHYSICAL LIABILITY:** If it becomes necessary for the Vendor, either as principal, agent or employee, to enter upon the premises or property of the Government of Guam in order to construct, erect, inspect, make delivery or remove property hereunder, the Vendor hereby covenants and agrees to take, use, provide and make all proper, necessary and sufficient precautions, safeguards and protections against the occurrence of any accidents, injuries or damages to any person or property during the progress of the work herein covered, and to be responsible for, and to indemnify and save harmless the Government of Guam from the payment of all sums of money by reason of all or any such accidents, injuries or damages that may occur upon or about such work, and fines, penalties and loss incurred for or by reasons of the violations of any territorial ordinance, regulations, or the laws of Guam or the United States, while the work is in progress. Contractor will carry insurance to indemnify the Government of Guam against any claim for loss, damage or injury to property or persons arising out of the performance of the Contractor or his employees and agents of the services covered by the contract and the use, misuse or failure of any equipment used by the contractor or his employees or agents, and shall provide certificates of such insurance to the Government of Guam when required.

[X] 43. **INSURANCE COVERAGE REQUIRED:** The amount of insurance required shall be determined by the Port's General Manager depending upon the type of activity conducted, or to be conducted by the owners or operators of vehicles entering the Port's facilities other service providers accessing on foot.

- A. Commercial General Liability Including Broad Form Property Damage and Contractual Liability \$1,000,000.00 combined single limit of liability
- B. Worker's Compensation - Statutory
- C. Automobile Liability - \$1,000,000.00 combined single limit of liability

Insurance Company: The insurance coverage(s) must be issued by those insurance companies who are licensed to do business on Guam, as determined by the Insurance Commissioner of the Department of Revenue and Taxation.

Additional Insurance Provision: All Commercial Insurance policies possessed by owners or operators of vehicles entering or using the Port's facilities and/or grounds must name the Port as an additional insured in their policies and specify that the Port shall be given at least thirty (30 days) prior written notice of any cancellation, material change or reduction in coverage.

Proof of Insurance: An Insurance Certificate must be issued listing all the vehicles, equipment, trucks covered under the insurance policy and filed with the Port Police Division. The insurance should include;

Name of the Insured (The Port must be shown as an Additional Insured on all Commercial Insurance policies)

- Policy Number
- Effective Date of Policy
- Limits of Insurance
- Description of Coverage Provided; and
- Name of Issuing Company

A certified copy of the Insurance Certificate must be carried in each vehicle, equipment and/or truck entering the Port facilities. This proof of insurance must be provided to the Port Police Division on an annual basis at least ten (10) days before the insurance policy expires.

Notice of Loss: In the event a Port tenant or user is involved in an accident within the Port's facilities or while on Routes 11A or 11B (Cabras Highway) and results in bodily injury or property damage, the Port Police Division must be immediately notified.

Workers' Compensation: All business entities entering or using the Port's facilities must also possess Workers' Compensation Insurance coverage as prescribed by Guam laws and copies of such Certificate of Insurance are to be filed with the Port Police Division. Each certification shall specify that the Port shall be given at least thirty (30) days prior written notice of any cancellation, material change or reduction in coverage.

Interchange Agreement: In lieu of fulfilling the maximum the maximum insurance requirements listed herein, the Port user must provide to the Port a current Interchange Agreement. The primary company must have fulfilled the maximum insurance requirements listed above. The Interchange Agreement must specifically state and name the Port user as additional insured and the duration of coverage. The Port must be notified thirty (30) days prior written notice of any cancellation, materials change or reduction in coverage.

[X] 44. Contract will be cancelled if funds not appropriated or insufficient, and that government will timely inform contractor. 2 GAR, Div.4 §3121(e) (1) (C) and 2 GAR, Div.4 § 3121(e)(1)(D).

[] 45. If cancelled, contractor will be reimbursed unamortized reasonably incurred non-recurring costs. 2 GAR, Div.4 § 3121(e) (1) (G).

[X] 46. **CONTACT FOR CONTRACT ADMINISTRATION:** If your firm receives a contract as a result of this Solicitation, please designate a person whom we may contact for prompt administration.

[X] 47. **WOMEN-OWNED BUSINESS PREFERENCE:** Bidding is subject to the policy in favor of Women-Owned Businesses pursuant to "The Support for Women-Owned Business Act" enacted by Public Law No. 36-26 and codified in 5 GCA section 5013.

[X] 48. **FEDERAL GSA SCHEDULES:** This IFB is federally funded under MARAD FY2022 American Marine Highway (AMH) Grant No.: 6931F72340007. The Port Authority of Guam is accepting Federal GSA pricing inclusive with shipping cost to Guam. If the bid pricing existing on the Federal GSA website from a qualified vendor for qualifying items on the date of opening of the bids, plus the confirmed price of shipping costs to Guam, confirmed after the opening of the bids, is the lowest price, then the contract will be awarded to that vendor.

[X] 49. **SIGNATURES**

This Agreement may be signed by the parties electronically, and in any number of counterparts, each of which shall be deemed an original, but all of which together shall constitute one and the same instrument. Delivery of an executed counterpart by one party to the other may be made by electronic transmission.

Name: _____ Title: _____

Address: _____ Telephone: _____

GOVERNMENT OF GUAM

SEALED BID SOLICITATION INSTRUCTIONS

1. **BID FORMS:** Each bidder shall be provided with one (1) sets of Solicitation forms. Additional copies may be provided upon request. Bidders requesting additional copies of said forms will be charged per page in accordance with 5 GCA § 10203 of the Government Code of Guam. All payments for this purpose shall be by cash, certified check or money order and shall be made payable to the PORT AUTHORITY OF GUAM (EO 86-24).

2. **PREPARATIONS OF BIDS:**
 - 2.0 Bidders are required to examine the drawings, specifications, schedule, and all instructions. Failure to do so will be at bidder's risk.

 - 2.1 Each bidder shall furnish the information required by the Solicitation. The bidder shall sign the Solicitation and print or type his name on the Schedule. Erasures or other changes must be Initialed by the person signing the bid. Bids signed by an agent are to be accompanied by evidence of this authority unless such evidence has been previously furnished to the issuing office.

 - 2.2 Unit price for each unit offered shall be shown and such price shall include packing unless otherwise specified. A total shall be entered in the amount column of the Schedule for each item offered. In case of discrepancies between a unit price and extended price, the unit price will be presumed to be correct.

 - 2.3 Bids for supplies or services other than those specified will not be considered. Time, if stated as a number of days, means calendar days and will include Saturdays, Sundays, and holidays beginning the day after the issuance of a Notice to Proceed. Time stated ending on a Saturday, Sunday or Government of Guam legal holiday will end at the close of the next business day.

 - 2.4 No Entitlement To Preparation Costs – the bidder expressly waives any right it may have against the government for any expenses incurred in connection with the preparation of its bid.

3. **EXPLANATION TO BIDDERS:** Any explanation desired by a bidder regarding the meaning or interpretation of the Solicitation, drawings, specifications, etc., must be submitted in writing and with sufficient time allowed for a written reply to reach all bidders before the submission of their bids. Oral explanations or instructions given before the award of the contract will not be binding. Any information given to a prospective bidder concerning a Solicitation will be furnished to all prospective bidders in writing as an amendment to the Solicitation if such information would be prejudicial to informed bidders.

4. **ACKNOWLEDGEMENT OF AMENDMENTS TO SOLICITATIONS:** Receipt of an amendment to a Solicitation by a bidder must be acknowledged by signing an acknowledgement of receipt of the amendment. Such acknowledgement must be received prior to the hour and date specified for receipt of bids.

5. **BID SUBMISSIONS:**
 - a) All Bids and bid documents must be submitted in writing. Bids and modifications thereof shall be enclosed in sealed envelopes if submitting in hardcopy, and addressed to the office specified in the Solicitation. Sealed hard copy bids shall be submitted in a sealed envelope to include one (1) fully executed original and one (1) copy. The outer envelope shall be marked in bold letters, Re-bid for 180' Telescopic Boom Lift (IFB-PAG-013-24). The bidder shall show the hour and date specified in the Solicitation for receipt, the Solicitation number, and the name and address of the bidder or authorized representative on the face of the envelope if submitting in hard copy.

 - b) E-mail submissions of written bids will be accepted. PAG will accept timely electronic submission of Bids by e-mail to the single Point of Contact, Mark A. Cabrera, at ifb.pag.013.24@gmail.com before the time and date for the opening of bids. Bids electronically submitted to any other person through any other method of electronic transmission will not be accepted. If submitting a Bid by e-mail, the subject line of the e-mail transmission shall contain the Bidder's name and the name of the Bidder's authorized representative, along with the following caption: Re-bid for 180' Telescopic Boom Lifts (IFB-PAG-013-24). Bids may be modified or withdrawn by written notice, provided such notice is

- is received prior to the hour and date specified for receipt, pursuant to the Guam Procurement Rules & Regulations.
- c) Bids and Bid Documents may be signed by the Bidder electronically, and in any number of counterparts, each of which shall be deemed an original, but all of which together shall be submitted with the Bid and shall constitute the Bid. Failure to submit the required forms in the number or format required may be cause for rejection of Bids due to non-responsiveness.
 - d) Samples of items, when required, must be submitted within the time specified, unless otherwise specified by the Government, at no expense to the Government. If not destroyed by testing, samples will be returned at bidder's request and expense, unless otherwise specified by the Solicitation.
 - e) Samples or descriptive literature should not be submitted unless it is required on this solicitation. Regardless of any attempt by a bidder to condition the bid, unsolicited samples or descriptive literature will not be examined or tested at the bidder's risk, and will not be deemed to vary any of the provisions of this Solicitation.
6. **FAILURE TO SUBMIT BID:** If no bid is to be submitted, do not return the solicitation unless otherwise specified. A letter or postcard shall be sent to the Issuing office advising whether future Solicitations for the type of supplies or services covered by this Solicitation are desired.
7. **LATE BID, LATE WITHDRAWALS, AND LATE MODIFICATIONS:**
- a) Definition: Any bid received after the time and date set for receipt of bids is late. Any withdrawal or modification of a bid received after the time and date set for opening of bids at the place designated for opening is late (Guam Procurement Regulations 2 GAR, Div.4 §3109(k)).
 - b) Treatment: No late bid, late modification, or late withdrawal will be considered unless received before contract award, and the bid, modification, or withdrawal would have been timely but for the action or inaction of territorial personnel directly serving the procurement activity.
8. **DISCOUNTS:**
- a) Notwithstanding the fact that prompt payment discounts may be offered, such offer will not be considered in evaluating bids for award unless otherwise specified in the Solicitation. However, offered discounts will be taken if payment is made within the discount period, even though not considered in the evaluation of bids.
 - b) In connection with any discount offered, time will be computed from date of delivery and acceptance of the supplies to the destination as indicated in the purchase order or contract. Payment is deemed to be made for the purpose of earning the discount on the date of mailing of the Government check.
9. **GOVERNMENT FURNISHED PROPERTY:** No material, labor or facilities will be furnished by the Government unless otherwise provided for in the Solicitation.
10. **SELLER' INVOICES:** Invoices shall be prepared and submitted in quadruplicate (one copy shall be marked "original") unless otherwise specified. Invoices shall be "certified true and correct" and shall contain the following information: Contract and order number (if any), item numbers, description of supplies or services, sizes, quantities, unit prices, and extended total. Bill of lading number and weight of shipment will be shown for shipments made on Government bills of lading.
11. **RECEIPT, OPENING AND RECORDING OF BIDS:** Bids and modifications shall be publicly opened in the presence of one or more witnesses, at the time, date, and place designated in the Invitation for Bids. The name of each bidder, the bid price, and such other information as is deemed appropriate by the Procurement Officer, shall be read aloud and recorded, or otherwise made available. The names and addresses of required witnesses shall be recorded at the opening. The opened bids shall be available for public inspection except to the extent the bidder designates trade secrets or other proprietary data to be confidential as set forth in accordance with Section 12, below. Material so designated shall accompany the bid and shall be readily separable from the bid in order to facilitate public inspection of the non-confidential portion of the bid. Prices, makes and models or catalogue numbers of the items offered, deliveries, and terms of payment shall be publicly available at the time of bid opening regardless of any designation to the contrary (Guam Procurement Regulations 2 GAR, Div.4 §3109(k)).

12. **CONFIDENTIAL DATA:** If a bidder considers any information submitted in its bid to be confidential, the bidder must identify in writing to the Government those portions which it considers confidential, and must request in writing that those portions be kept confidential. Only trade secrets and proprietary data will be considered confidential. If there is a request for confidentiality, the Government will render a decision on the request as soon as practicable after bids are opened. The Government will advise any bidder requesting confidentiality, of the Government's decision in writing. If the Government does not agree with a bidder's request, then the Government will inform the bidder that it may lodge a protest regarding any part of the Government's decision by following the procedure for protests outlined in Chapter 9 of the Guam Procurement Regulations.
13. **PROHIBITION AGAINST GRATUITIES AND KICKBACKS:** With respect to this procurement and any other contract that bidder may have or wish to enter into with the Government, the bidder represents that he/she has not violated, is not violating, and promises that he will not violate the prohibition against gratuities and kickbacks set forth in the Guam Procurement Regulations.
14. **STATEMENT OF QUALIFICATIONS:** The ability capacity and skill of the Bidders to perform; Whether the bidder can perform promptly or within the specified time; The quality of performance of the Bidder with regards to awards previously made to him; The sufficiency of the financial resources and ability of the bidders to perform; and the compliance with all of the conditions to the solicitation.
15. **WAGE AND BENEFIT COMPLIANCE-CONTRACTORS PROVIDING SERVICES**
- a) Contractor with regard to all person its employs whose purpose in whole or in part is the direct delivery of services contracted for with the Government of Guam in this procurement, shall pay such employees in accordance with the Wage Determination for Guam and the Northern Marianas Islands issued and promulgated by the U.S. Department of Labor for such labor as is employed in the direct deliverance of deliverables to the government of Guam. 5 GCA § 5801 Contractor shall be responsible for flowing down this obligation to its subcontractors.
 - b) The Wage Determination most recently issued by the U.S. Department of Labor at the time this Agreement was awarded to Contractor shall be used to determine wages and benefits which shall be paid to employees pursuant to this clause. 5 GCA § 5801
 - c) Should any contract contain a renewal clause, then at the time of renewal adjustments there shall be stipulations contained in that contract for applying the Wage Determination, so that the Wage Determination promulgated by the U.S Department of Labor on a date most recent to the renewal date shall apply. 5 GCA § 5801
 - d) In addition to the Wage Determination detailed above, health and similar benefits for employees having a minimum value as detailed in the Wage Determination issued and promulgated by the U.S. Department of Labor shall apply. Contractor shall pay a minimum of ten (10) paid holidays per annum per employee. 5 GCA § 5802
 - e) Any violation of Contractor or its subcontractor's obligations of this section shall be investigated by the Guam Department of Labor and may include a monetary penalty assessment by the Guam Department of Labor of no less than One Hundred Dollars (\$100.00) per day, and no more than One Thousand Dollars (\$1,000.00) per day, until such time as a violation has been corrected, as well as the payment of all back wages and benefits due. 5 GCA § 5803
 - f) In addition to any and all other breach of contract actions the Government of Guam may have under this procurement, in the event there is a violation in the process set forth in subsection (e) above, Contractor may be placed on probationary status by the GENERAL MANAGER of the General Service Agency, or its successor, for a period of one (1) year.

During the probationary status, a Contractor shall not be awarded any contract by any instrumentality of the Government of Guam. A Contractor who has been placed on probationary status, or has been assessed a monetary penalty pursuant to 5 G.C.A. Article 13 Title 5 may appeal such penalty or probationary status to the Superior Court of Guam. 5 GCA § 5804
 - g) Contractor along with all proposed Offerors and submitter under this procurement were required to submit a Declaration of Compliance with Wage Determination laws as part of this procurement

with a copy of the most recent Wage Determination for Guam and the Northern Marianas Islands issued and promulgated by the U.S. Department of Labor. 5 GCA §5805

- h) The applicable USDOL Wage Determination Rate Revision (as defined by subsections (b) and (c)) is to this Agreement. Contractor agrees to provide upon written request by the Government of Guam written certification of its compliance with its obligations as part of each invoice, along with the names of any employees, their positions, and detailed wage and benefits paid in keeping with this section. Additionally, upon request by Government of Guam the Contractor shall submit source documents as to those individuals provide direct services in part or whole under this Agreement and its payments to them of such wages and benefits.

16. **ETHICAL STANDARDS:** With respect to this procurement and any other contract that the Contractor may have, or wish to enter into, with any government of Guam agency, the Contractor represents that it has not knowingly influenced, and promises that it will not knowingly influence, any government employee to breach any of the ethical standards set forth in the Guam Procurement Law and in any of the Guam Procurement Regulations.

17. **PROHIBITION AGAINST CONTINGENT FEES:** The Contractor represents that he has not retained any person or agency upon an agreement or understanding for a percentage, commission, brokerage, or other contingent arrangement, except for retention of bona fide employees or bona fide established commercial selling agencies, to solicit or secure this Agreement or any other contract with the government of Guam or its agencies.

18. **CONTRACTOR'S WARRANTY AS TO EMPLOYEES AND SEX OFFENSES.** *Reference 5 GCA 5253 (b)*
Contractor warrants that no person providing services on behalf of the Contractor has been convicted of a sex offense under the provisions of Chapter 25 of Title 9 of GCA or an offense as defined in Article 2 of Chapter 28, Title 9 GCA, or an offense in another jurisdiction with, at a minimum, the same elements as such offenses, or who is listed on the Sex Offender Registry.

Contractor warrants that if any person providing services on behalf of Contractor is convicted of a sex offense under the provisions of Chapter 25 of Title 9 GCA, or an offense as defined in Article 2 of Chapter 28, Title 9 GCA, or an offense in another jurisdiction with, at a minimum, the same elements as such offenses, or who is listed on the Sex Offender Registry, that such person will be immediately removed from working at said agency and that the administrator of said agency be informed of such within twenty-four (24) hours of such conviction. Any contractor found in violation of this section, after notice from the Government of Guam, after notice from the contracting authority of such violation, shall within twenty-four (24) hours, take corrective action and shall report such action to the contracting authority. Failure to take corrective action with the stipulated period may result in the temporary suspension of the contract at the discretion of the Government of Guam.

19. **POLICY IN FAVOR OF SERVICE-DISABLED VETERAN OWNED BUSINESSES** P.L. 31-115 (September 20, 2011) 5 GCA § 5011 and § 5012 In the procurement of any supply or service, (except for professional services), if such supply or service is offered by a Service-Disabled Veteran Owned Business "SDVOB", as defined in 5 GCA § 5012, that is at least fifty one percent (51%) owned by service-disabled veteran(s), and if the supply or service is available within the period that is required for the procurement, and the price for the supply or service does not exceed one hundred five percent (105%) of the lowest bidder price, a preference shall be given to that SDVOB by the Government of Guam, and the supply or service shall be purchased from said SDVOB. This shall be in addition to any other procurement benefit the SDVOB may qualify for under Guam law. A business concern is a qualified SDVOB if: (a) the business concern is licensed to do business on Guam; (b) the business concern maintains its headquarters on Guam; (c) the business concern is at least fifty-one (51%) owned by a service-disabled veteran(s) who served in the active U.S. military service, was discharged or released under honorable conditions and whose disability is service-connected as demonstrated by a DD214, and certified by an award letter from the U.S. Department of Veterans Affairs; the DD214 and Disability award letter from U.S. Department of Veterans Affairs are submitted to the Government of Guam procuring agency for every service offered; and the service disabled veteran(s) owner(s) of the business concern has filed individual tax returns on Guam for a period of at least three (3) consecutive years.

20. **Policy In Favor of Women-Owned Businesses.** (a) Notwithstanding any other provision of law, if any entity of the government of Guam or any entity expending governmental funds intends to procure any

supply or service which is offered by a business concern that is at least fifty-one percent (51%) owned by women, that entity shall procure such supply or service from that business concern if the supply or service is available within the period required by the procuring entity and the price for the supply or service does not exceed one hundred five percent (105%) of the lowest price bidder, and shall be in addition to any other procurement benefit the women-owned business may qualify for under Guam law. The procuring entity shall determine the lowest price to the entity in the case of more than one (1) women-owned business, or a women-owned business and a service-disabled veteran owned business, who are competing for the same government contract. (b) Qualifications of a Women-Owned Business. A business concern is qualified under Subsection (a) of this Section if: (1) the business concern is licensed to do business on Guam; (2) the business concern maintains its headquarters on Guam; (3) the business concern is at least fifty-one percent (51%) owned by women, who manage day-to-day operations and make long-term decisions; (4) the business concern is certified as a Women-Owned Small Business (WOSB) or an Economically Disadvantaged Women-Owned Small Business (EDWOSB) by the U.S. Small Business Administration; and (5) the owner(s) of the business concern has (have) filed individual tax returns on Guam for a period of at least three (3) consecutive years.

ITEM NO.	DESCRIPTION	QUANTITY	UNIT	UNIT PRICE	EXTENSION
1.1	Telescopic Boom Lift, 180' Reach Full time 4WD	1	EA.	\$ _____	\$ _____

GENERALS: These specifications have been written, to describe minimum equipment and performance requirements to be supplied by the equipment manufacture bidding. Reasonable test may be conducted upon delivery before acceptance.

The successful bidder shall furnish all necessary and desirable information and instructions for the proper operation of the equipment.

The government reserves the right to accept and/or reject any and all bids, to waive any defects, irregularities, or specification discrepancies and to award the bid as council deems to be in the best interest of the government.

DISCREPANCIES

LISTED: Should any bidder have deviations from these specifications in his bid and cannot meet every requirement of the specifications, he shall submit a letter and attach it to the bid, explaining the deviations, failure to do so will cause the bid to be rejected as being non-responsive.

DELIVER: The successful bidder shall deliver one (1) 180' Boom Lift each be new fully assembled and ready for operation to the Port Authority of Guam within 120 days.

SPECIFICATIONS:

BIDDING AND OR REMARKS:

Engine:	74 hp minimum, Diesel Engine Engine shutoff protection system (Low Oil Pressure, High Engine Temperature High Transmission Temperature)	_____
Fuel Type:	Diesel (Ultra Low Sulfur) Tier IV	_____
Fuel Tank:	The fuel tank furnished shall be Min. 50 gallon	_____
Platform reach:	180ft & 10ft jib	_____
Platform Dimensions:	36 x 96 with railing & side entry	_____
Platform Capacity:	Unrestricted - 500 lbs	_____
	Restricted - 750 lbs	_____
Platform Rotation:	160 degrees	_____
Swing:	360 degrees continuous	_____
Steering:	Selectable Steering (ground level or platform)	_____
Axles:	Extendable front and rear	_____
Gauges:	Air, Fuel, Hour, Volt, Temp, and Oil	_____
Lights:	2 Headlights in facing forward with protective guard, 2 Headlights facing rear with protective guard, 2 work lights on platform	_____
Tires:	Protector Lug Foam Filled tires	_____
Manlift Accessories:	Platform to be plumbed with air lines for use of pneumatic Tools	_____
	Hostile Weather/Environment Kit	_____
	AC plug/outlet in platform	_____

Accessories: Standard manufacture accessories to include
 Horn - Electric
 Amber strobe light, key switch "on position" activated.
 Mounted 5 lbs. fire extinguisher on platform
 1 set "Shop Type" repair manuals and complete
 illustrated parts manual.
 Diagnostic and Troubleshooting software
 Owner/Operator manual for each equipment
 Maintenance and Service manual for each equipment
 Warranty booklet for each equipment
 Recommended spare parts list
 All fluids to the fullest level
 Fuel tank to be loaded with 10 gallons of diesel.
 Electronic Backup alarm
 Engine shut-off protection system (Low Oil Pressure,
 High Engine Temperature and High Transmission
 Temperatures),
 Reflective Conspicuity Tape
 Electronic rust prevention system

Receiving Date: (Acceptance Date) will be Three (3) days after delivery Date, provided the Equipment is Delivered Completely Assembled and meets all specifications, terms and conditions of the bid requirements.

Special Provision: If parts catalog and maintenance repair comes in CD-ROM or Microfiche, bidder must supply to requesting agency. Bidder must still provide hard (book) copy to the requesting agency.

Applicable Federal Laws And Regulations: Buy American Act - 41 U.S.C § 8301-8305
 Build America Buy America Act Certificate must be provide by the manufacture.

Training: Provide 2 sessions on pre inspection, post inspection and safe operational procedures for all operators, leaders, supervisors and dispatchers within Maintenance division.

Warranty: Manufacturers Standard Warranty, 1 year limited warranty. Service of one (1) year/ 2,000 hours, all parts, labor and oil disposal shall be included at "No Cost to the Government".

- Yes, offer as requested. _____
- No, Offer the following: _____

The manufacturer Warranty and Boucher shall be specified on items covered and provided in the bid packet. (Bid submission received without written warranty and Boucher as specified will be rejected).

- Yes, offer as requested. _____
- No, Offer the following: _____

The successful bidder shall provide technical assistance and warranty administration without any cost to "The Port Authority of Guam"

- [] Yes, offer as requested.
[] No, Offer the following:

The successful bidder shall provide service, such as to determine deficiency, repair or adjustment of the equipment on government premises or transfer the equipment to the shop where the repair should be done, at anytime within the warranty period and at "No cost to the Government".

- [] Yes, offer as requested.
[] No, Offer the following:

The manufacture shall have a local authorized dealer who can provide factory trained service technician(s). Bidder shall provide certification of factory trained technician(s) for the above equipments be purchased during commissioning.

- [] Yes, offer as requested.
[] No, Offer the following:

Provide Complete Familiarization Training to Port Representatives on maintenance of Mechanical, Electrical and Hydraulic systems on units by manufacturer. All costs Associated with training (airfare, lodging and transportation) are to be included At no cost to the Government of Guam.

- [] Yes, offer as requested.
[] No, Offer the following:

This project is funded under ther Fiscal Year 2022 America's Marine Highway (AMH) Program Grant No.: 693JF72340007

Certification requirements for procurement of steel, iron, construction materials, or manufactured products. If steel, iron, construction materials, or manufactured products (as defined in § 70914(a) of the Build America, Buy America Act, Pub. L. No. 117-58, div. G, tit. IX, subtit. A, 135 Stat. 429, 1298 (2021) and Office of Management and Budget (OMB) Memorandum M-22-11, "Initial Implementation Guidance on Application of Buy America Preference in Federal Financial Assistance Programs for Infrastructure," as implemented by MARAD through Term B.5 of the exhibits to the agreement) are being procured, the same or equivalent certificate as set forth below shall be completed and submitted by each bidder or offeror in accordance with the requirement contained in section 2.1 of the agreement.

Certificate of Compliance with Buy America Requirements
The bidder or offeror hereby certifies that it will comply with the requirements of § 70914(a) of the Build America, Buy America Act, Pub. L. No. 117-58, div. G, tit. IX, subtit. A, 135 Stat. 429, 1298 (2021), as implemented by MARAD in Term B.5 of the exhibits to the grant agreement.

Date
Signature
Company
Name
Title

Certificate of Non-Compliance with Buy America Requirements
The bidder or offeror hereby certifies that it cannot comply with the requirements of § 70914(a) of the Build America, Buy America Act, Pub. L. No. 117-58, div. G, tit. IX, subtit. A, 135 Stat. 429, as implemented by MARAD in Term B.5 of the exhibits to the grant agreement, but it may qualify for an exception to the requirement pursuant to § 70914(b) of the Build America, Buy America Act and Term B.5.

Date
Signature
Company
Name
Title

Notes: Bidder shall identify on their bids, any deviations from the specifications or requirements in the remarks column and state the item being offered for evaluation processing. Failure to comply may result in the rejection of the bid.

A certificate of origin is required on the sale of equipment.

Equipment must be delivered to the Port Authority of Guam for inspection

Bidding on: Telescopic Boom Lift 180' reach, Full time 4WD

MANUFACTURER: _____

MAKE: _____

MODEL: _____

YEAR: _____

PLACE OF ORIGIN: _____

DATE OF DELIVERY: _____

These specifications have been developed by Port Authority of Guam's, Raymond B. Santos- Transportation Superintendent, Joaquin P. Pangelinan- Equipment Service Support Manager, reviewed by Glenn B. Nelson- Operations Manager, Dominic G. Muna- DGMO, Pacifico Martir- DGMA, and approved by Rory J. Respicio- General Manager

1850SJ
TELESCOPIC FORK LIFT TRUCK

1800LITRE

JLG

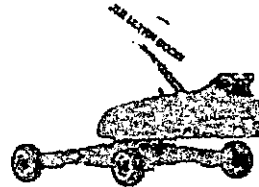

KEY SPECS

Platform Height
185-4174 / 5636-m

Drive Speed
23.00 / 41.10-h

Horizontal Outreach
20-71 / 23.25-m

Platform Capacity
1500kg / 3300kg - Overload
1000kg / 2200kg - Overload

KEY FEATURES

- Ergonomic work area of a wide range platform height of 185-4174 m, telescopic outreach of 20-71 m, and a 1500kg platform capacity.
- Forward/reverse 16 speed hydrostatic transmission, 40 km/h top speed, 20 km/h reverse, 10 km/h forward.
- 1500kg platform capacity, 1000kg overload.
- 1500kg platform capacity, 1000kg overload.

ACCESSORIES & OPTIONS

- 1500kg platform capacity
- 1000kg overload
- 1500kg platform capacity
- 1000kg overload
- 1500kg platform capacity
- 1000kg overload
- 1500kg platform capacity
- 1000kg overload
- 1500kg platform capacity
- 1000kg overload
- 1500kg platform capacity
- 1000kg overload
- 1500kg platform capacity
- 1000kg overload
- 1500kg platform capacity
- 1000kg overload

STANDARD SPECIFICATIONS

Performance	Standard
Platform Height	185-4174 / 5636-m
Horizontal Outreach	20-71 / 23.25-m
Platform Capacity	1500kg / 3300kg - Overload 1000kg / 2200kg - Overload
Drive Speed	23.00 / 41.10-h
Engine	1500cc / 1500cc
Hydraulic System	1500cc / 1500cc
Transmission	16 speed hydrostatic
Top Speed	40 km/h
Reverse Speed	20 km/h
Forward Speed	10 km/h
Platform Capacity	1500kg / 3300kg - Overload 1000kg / 2200kg - Overload

STANDARD FEATURES

- 1500kg platform capacity
- 1000kg overload
- 1500kg platform capacity
- 1000kg overload
- 1500kg platform capacity
- 1000kg overload
- 1500kg platform capacity
- 1000kg overload
- 1500kg platform capacity
- 1000kg overload
- 1500kg platform capacity
- 1000kg overload
- 1500kg platform capacity
- 1000kg overload
- 1500kg platform capacity
- 1000kg overload

DIMENSIONS

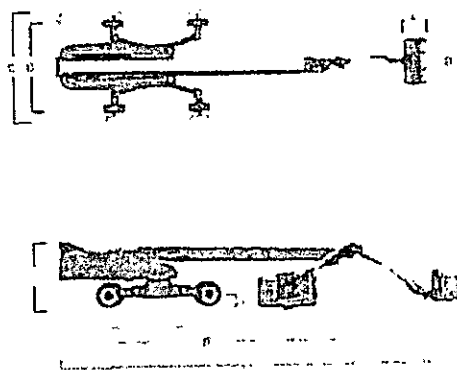

- A. Platform Height
- B. Platform Length
- C. Maximum Platform Capacity
- D. Platform Width
- E. Telescopic Boom
- F. Maximum Reach
- G. Maximum Height
- H. Maximum Length
- I. Wheelbase
- J. Track Distance

REACH DIAGRAM

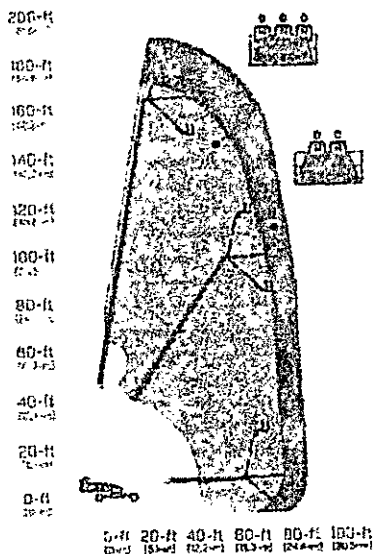

The JLG 185 warranty is a limited warranty that covers the cost of parts and labor for the first 185 hours of operation. This warranty is valid only for the first 185 hours of operation. After 185 hours, the warranty is no longer valid. The JLG 185 warranty is a limited warranty that covers the cost of parts and labor for the first 185 hours of operation. This warranty is valid only for the first 185 hours of operation. After 185 hours, the warranty is no longer valid.



JLG INDUSTRIES, INC.
 One Tree Hill Drive, JLG
 JLG 185
 An Oshkosh Corporation Company

PORT AUTHORITY OF GUAM FEDERAL CONTRACT SUPPLEMENT

All boxes marked below are terms and conditions applicable to the Agreement entered by the Port Authority of Guam ("PAG") and Contractor, which is funded in whole or in part by federal award funds, as supplemented with these federally required terms. To the extent that any of the contractual terms, provisions, or conditions of the Agreement are inconsistent with the applicable terms, provisions, or conditions of this Federal Contract Supplement, the applicable terms of this Federal Contract Supplement shall govern.

DOMESTIC PRODUCTS PREFERENCE

As appropriate and to the extent consistent with law, there is a preference for the purchase, acquisition, or use of goods, products, or materials produced in the United States (including but not limited to iron, aluminum, steel, cement, and other manufactured products). The requirements of this section must be included in all subcontracts, including all purchase orders for work or products under this subaward. For purposes of this section: "Produced in the United States" means, for iron and steel products, that all manufacturing processes, from the initial melting stage through the application of coatings, occurred in the United States.

PROHIBITION ON CERTAIN TELECOMMUNICATIONS AND VIDEO SURVEILLANCE SERVICES AND EQUIPMENT

For the purpose of public safety, security of government facilities, physical security surveillance of critical infrastructure, and other national security purposes, Contractor and all subcontractors are prohibited from procuring, obtaining, or purchasing: 1) equipment, services, or systems that uses covered telecommunications equipment or services as a substantial or essential component of any system, or as critical technology as part of any system. As described in Public Law 115-232, section 889, covered telecommunications equipment is telecommunications equipment produced by Huawei Technologies Company or ZTE Corporation (or any subsidiary or affiliate of such entities); 2) video surveillance and telecommunications equipment produced by Hytera Communications Corporation, Hangzhou Hikvision Digital Technology Company, or Dahua Technology Company (or any subsidiary or affiliate of such entities); 3) telecommunications or video surveillance services provided by such entities or using such equipment; and 4) telecommunications or video surveillance equipment or services produced or provided by an entity that the Secretary of Defense, in consultation with the Director of the National Intelligence or the Director of the Federal Bureau of Investigation, reasonably believes to be an entity owned or controlled by, or otherwise connected to, the government of a covered foreign country.

PROCUREMENT OF RECOVERED MATERIALS

Contractor and all subcontractors must comply with section 6002 of the Solid Waste Disposal Act, as amended by the Resource Conservation and Recovery Act. The requirements of Section 6002 include procuring only items designated in guidelines of the Environmental Protection Agency (EPA) at 40 CFR part 247 that contain the highest percentage of recovered materials practicable, consistent with maintaining a satisfactory level of competition, where the purchase price of the item exceeds \$10,000 or the value of the quantity acquired during the preceding fiscal year exceeded \$10,000; procuring solid waste management services in a manner that maximizes energy and resource recovery; and establishing an affirmative procurement program for procurement of recovered materials identified in the EPA guidelines.

UNALLOWABLE COSTS

Contractor agrees to comply with all applicable laws, regulations, policies, and guidance (including specific cost limits, prior approval and reporting requirements, where applicable) governing the use of federal funds. Costs that are expressly unallowable under federal funding laws, or costs which specifically become designated as unallowable as a result of a written decision furnished by a contracting officer pursuant to contract dispute procedures, or costs which are mutually agreed to be unallowable, including mutually agreed to be unallowable directly associated costs, shall be identified and excluded from any invoice, billing, claim, or proposal applicable to a federally funded contract. A directly associated cost is any cost which is generated solely as a result of incurring another cost, and which would not have been incurred had the other cost not been incurred. When an unallowable cost is incurred, its directly associated costs are also unallowable. Contractor agrees to pay any penalties associated with any unallowable costs.

NO OBLIGATION BY THE FEDERAL GOVERNMENT

PAG and Contractor acknowledge and agree that, notwithstanding any concurrence by the Federal Government in or approval of the solicitation or award of the underlying Agreement, absent the express written consent by the Federal Government, the Federal Government is not a party to this contract and shall not be subject to any obligations or liabilities to PAG. Contractor, or any other party (whether or not a party to the contract) pertaining to any matter resulting from the underlying contract. Contractor agrees to include the above clause in each subcontract financed in whole or in part with Federal funds under this Agreement. It is further agreed that the clause shall not be modified, except to identify the subcontractor who will be subject to its provisions.

FEDERAL LOBBYING

The Contractor certifies, to the best of his or her knowledge and belief, that:

A. No Federal appropriated funds have been paid or will be paid, by or on behalf of the undersigned, to any person for influencing or attempting to influence an officer or employee of an agency, a Member of Congress, an officer or employee of Congress, or an employee of a Member of Congress in connection with the awarding of this Agreement, the making of any Federal grant, the making of any Federal loan, the entering into of any cooperative agreement, and the extension, continuation, renewal, amendment, or modification of this Agreement or any Federal grant, loan, or cooperative agreement.

B. If any funds other than Federal appropriated funds have been paid or will be paid to any person for making lobbying contacts to an officer or employee of any agency, a Member of Congress, an officer or employee of Congress, or an employee of a Member of Congress in connection with this Agreement, or any Federal grant, loan, or cooperative agreement, the undersigned shall complete and submit Standard Form--LLL, "Disclosure Form to Report Lobbying," in accordance with its instructions [as amended by "Government wide Guidance for New Restrictions on Lobbying," 61 Fed. Reg. 1413 (1/19/96). Note: Language in paragraph (2) herein has been modified in accordance with Section 10 of the Lobbying Disclosure Act of 1995 (P.L. 104-65, to be codified at 2 U.S.C. 1601, et seq.)]

C. The Contractor shall require that the language of this certification be included in the award documents for all subawards at all tiers (including subcontracts, subgrants, and contracts under grants, loans, and cooperative agreements) and that all subcontractors shall certify and disclose accordingly.

D. This certification is a material representation of fact upon which reliance was placed when this transaction was made or entered into. Submission of this certification is a prerequisite for making or entering into this Agreement. The Contractor certifies or affirms the truthfulness and accuracy of each statement of this certification and disclosure. In addition, the Contractor understands and agrees that the provisions of 31 U.S.C. A 3801, et seq., apply to this certification and disclosure.

ALL PUBLISHED ITEMS AND DELIVERABLES MUST INCLUDE NAME OF FEDERAL AWARDING AGENCY AND AWARD NUMBER

Contractor agrees to include the Program logo and the logos of the Federal Awarding Agency, the PAG, and the government of Guam on any materials developed for publication. Contractor further agrees to ensure statements, press releases, public service announcements, media interviews, requests for proposals, bid solicitations, and other documents or activities carried out in whole or part with program funds shall clearly state: (1) the dollar amount of federal funds for the project; (2) the Federal Award Number; and (3) the involvement of the Federal Awarding Agency, the PAG, and the government of Guam.

DEBARMENT (GUAM AND FEDERAL)

A. **Guam Debarment and Suspension.** Contractor warrants that it will comply with the provisions of 5 GCA Chapter 5 Articles 9 and 11, subject to debarment or suspension, and that it will not employ any subcontractors who have been federally debarred or debarred by the Government of Guam.

B. **Federal Debarment and Suspension (Executive Orders 12549 and 12689).** A contract award (see 2 CFR 180.220) must not be made to parties listed on the government-wide exclusions in the System for Award Management (SAM), in accordance with the OMB guidelines at 2 CFR 180 that implement Executive Orders 12549 (3 CFR part 1986 Comp., p. 189) and 12689 (3 CFR part 1989 Comp., p. 235), "Debarment and

Suspension." SAM Exclusions contains the names of parties debarred, suspended, or otherwise excluded by agencies, as well as parties declared ineligible under statutory or regulatory authority other than Executive Order 12549. As required by Executive Order 12549, Debarment and Suspension, and implemented at 34 CFR Part 85, for prospective participants in primary covered transactions, as defined at 34 CFR Part 85, Sections 85.105 and 85.110. The Contractor certifies that it and its principals: 1) Are not presently debarred, suspended, proposed for debarment, declared ineligible, or voluntarily excluded from covered transactions by any federal department or agency; 2) Have not within a three-year period preceding this application been convicted of or had a civil judgment rendered against them for commission of fraud or a criminal offense in connection with obtaining, attempting to obtain, or performing a public (federal, state, or local) transaction or contract under a public transaction; violation of federal or state antitrust statutes or commission of embezzlement, theft, forgery, bribery, falsification or destruction of records, making false statements, or receiving stolen property; 3) Are not presently indicted for or otherwise criminally or civilly charged by a governmental entity (federal, state, or local) with commission of any of the offenses enumerated above; and 4) Have not within a three-year period preceding this application had one or more public transactions (federal, state, or local) terminated for cause or default. Contractor further warrants that it is not a party listed on the government wide exclusions in the System for Award Management (SAM), and will comply with the provisions of Subpart C of 2 CFR Part 1326, "Nonprocurement Debarment and Suspension," (published in the Federal Register on December 21, 2006, 71 FR 76573) which generally prohibits entities that have been debarred, suspended, or voluntarily excluded from participating in nonprocurement transactions either through primary or lower tier covered transactions, and which sets forth the responsibilities of recipients of federal financial assistance regarding transactions with other persons, including subrecipients and contractors. Contractor will provide a Certification Regarding Debarment, Suspension, Ineligibility, and Voluntary Exclusion, Lower Tier Covered Transaction (Sub-Recipient), which is a material representation of fact. Submission of this certification is a pre-requisite for entering into this Agreement, imposed by Executive Order 12549, 28 CFR Part 67, Section 67.510.

ACCESS TO RECORDS, INSPECTION, AND AUDIT REVIEW

A. **Access to Records.** The Contractor, including its subcontractors, if any, shall maintain all books, documents, papers, accounting records and other evidence pertaining to costs incurred and to make such materials available at their respective office at all reasonable times during the contract period and for three (3) years from the date of final payment under this Formal Agreement, for inspection by the PAG. Each subcontract by the Contractor pursuant to this Agreement shall include a provision containing the conditions of this Section.

B. **Right to Audit.** Contractor shall establish and maintain a reasonable accounting system that enables the PAG to readily identify Contractor's assets, expenses, costs of goods, and use of funds. The PAG and its authorized representatives shall have the right to audit, to examine, and to make copies of or extracts from all financial and related records (in whatever form they may be kept, whether written, electronic, or other) relating to or pertaining to this Agreement kept by or under the control of the Contractor, including, but not limited to those kept by the Contractor, its employees, agents, assigns, successors, and subcontractors. Such records shall include, but not be limited to, accounting records, written policies and procedures; subcontract files (including proposals of successful and unsuccessful bidders, bid recaps, etc.); all paid vouchers including those for out-of-pocket expenses; other reimbursement supported by invoices; ledgers; cancelled checks; deposit slips; bank statements; journals; original estimates; estimating work sheets; contract amendments and change order files; backcharge logs and supporting documentation; insurance documents; payroll documents; timesheets; memoranda; and correspondence. Contractor shall, at all times during the term of this Agreement and for a period of ten years after the completion of this Agreement, maintain such records, together with such supporting or underlying documents and materials. The Contractor shall at any time requested by the PAG, whether during or after completion of this Agreement, and at Contractor's own expense make such records available for inspection and audit (including copies and extracts of records as required) by the PAG. Such records shall be made available to the PAG during normal business hours at the Contractor's office or place of business and [subject to a three-day written notice/without prior notice]. In the event that no such location is available, then the financial records, together with the supporting or underlying documents and records, shall be made available for audit at a time and location that is convenient for the PAG. Contractor shall ensure the PAG has these rights with Contractor's employees, agents, assigns, successors, and subcontractors, and the obligations of these rights shall be explicitly included in any subcontracts or agreements formed between the Contractor and any subcontractors to the extent that those subcontracts or agreements relate to fulfillment of the Contractor's obligations to the PAG. Costs of any audits conducted under the authority of this right to audit and not addressed elsewhere will be borne by the PAG unless certain exemption criteria are met. If the audit identifies overpricing or overcharges (of any nature) by the Contractor to the PAG in excess of one-half of one percent (.5%) of the total contract billings, the Contractor shall reimburse the PAG for the total costs of the audit. If the audit discovers substantive findings related to fraud, misrepresentation, or non-performance, the PAG may recoup the costs of the audit work from the Contractor. Any adjustments and/or payments that must be made as a result of any such audit or inspection of the Contractor's invoices and/or records shall be made within a reasonable amount of time (not to exceed 90 days) from presentation of the PAG's findings to Contractor.

C. **Right to Enter and Inspect.** the PAG may, at any time, without notice, enter and inspect a Contractor's or subcontractor's facilities, place(s) of business, or any place(s) of performance of this Agreement. the PAG may enter and inspect any plans, supplies, services, equipment, work and records at these locations which are related to the performance of this Agreement, and may conduct any testing deemed necessary to determine whether the Contractor's or subcontractor's compliance or conformity to the solicitation or contract requirements. Guam may enter and audit the cost or pricing data, books, and records of the Contractor or any subcontractor, and/or investigate in connection with an action to debar or suspend a person from consideration for award of contracts pursuant to §9102 (Authority to Debar or Suspend) of the Guam Procurement Rules and Regulations.

FEDERAL REQUIREMENTS

Contractor agrees to comply with all applicable federal law, regulations, and executive orders, all standards, orders, requirements set forth under the federal award that is funding this Agreement, and all policies, procedures, and directives issued by the Federal Awarding Agency.

MODIFICATION

This Agreement may only be amended, modified, or extended in accordance with the applicable federal law, the terms and conditions of the federal award that is funding this Agreement, and the policies and procedures of the Federal Awarding Agency. Deviations from budget, project scope, objective, and/or time of performance require notification to the Federal Awarding Agency, and may require prior approval of the Federal Awarding Agency.

FALSE CLAIMS AND WHISTLEBLOWERS

Contractor acknowledges that 31 U.S.C. Chap. 38 (Administrative Remedies for False Claims and Statements) and Title 5 GCA Chapter 37, the False Claims and Whistleblower Act applies to this Agreement and to all Contractor's actions pertaining to this Agreement. The False Claims and Whistleblower Act was passed as Public Law 34-116, Chapter III, Section 20 (lapsed into law August 24, 2018) and codified at Title 5 GCA Chapter 37.

IMPLEMENTATION OF CLEAN AIR ACT AND FEDERAL WATER POLLUTION CONTROL ACT
(APPLICABLE TO ALL CONTRACTS AND SUBCONTRACTS EXCEEDING \$150,000)

Contractor agrees to comply with all applicable standards, orders, or requirements issued under Section 306 of the Clean Air Act (42 USC, 1857H), Section 508 of the Clean Water Act (33 USC, 1368), Executive Order 11378, and Environmental Protection Agency regulations (40 C.F.R., Part 15), which prohibit the use under nonexempt federal contracts, grants, or loans of facilities included on the EPA list of Violating Facilities. Contractor shall report violations to the PAG and to the USEPA Assistant Administrator for Enforcement (ENO329).

By executing this contract, and any subcontracts, as appropriate, the Contractor and any subcontractors will be deemed to have stipulated as follows:

A. That any person who is or will be utilized in the performance of this contract is not prohibited from receiving an award due to a violation of Section 508 of the Clean Water Act or Section 306 of the Clean Air Act.

B. That the Contractor agrees to include or cause to be included the requirements of paragraph (A) of this Section in every subcontract, and further agrees to take such action as the contracting agency may direct as a means of enforcing such requirements.

EQUAL EMPLOYMENT OPPORTUNITY COMPLIANCE
(APPLICABLE TO ALL CONSTRUCTION CONTRACTS AND SUBCONTRACTS)

The Contractor and all subcontractors must comply with the following policies: Executive Order 11246, 41 CFR 60, 29 CFR 1625-1627, Title 23 USC Section 140, the Rehabilitation Act of 1973, as amended (29 USC 794), Title VI of the Civil Rights Act of 1964, as amended, and related regulations including 49 CFR Parts 21, 26 and 27; and 23 CFR Parts 200, 230, and 633.

The Contractor and all subcontractors must also comply with: the requirements of the Equal Opportunity Clause in 41 CFR 60-1.4(b) and, for all construction contracts exceeding \$10,000, the Standard Federal Equal Employment Opportunity Construction Contract Specifications in 41 CFR 60-4.3.

A. Equal Employment Opportunity: Equal employment opportunity (EEO) requirements not to discriminate and to take affirmative action to assure equal opportunity as set forth under laws, executive orders, rules, regulations (28 CFR 35, 29 CFR 1630, 29 CFR 1625-1627, 41 CFR 60 and 49 CFR 27) and orders of the Secretary of Labor as modified by the provisions prescribed herein, and imposed pursuant to 23 U.S.C. 140 shall constitute the EEO and specific affirmative action standards for the Contractor's project activities under this contract. The provisions of the Americans with Disabilities Act of 1990 (42 U.S.C. 12101 et seq.) set forth under 28 CFR 35 and 29 CFR 1630 are incorporated by reference in this contract. In the execution of this contract, the Contractor agrees to comply with the following minimum specific requirement activities of EEO:

1) The Contractor will work with the PAG and the Federal Government to ensure that it has made every good faith effort to provide equal opportunity with respect to all of its terms and conditions of employment and in their review of activities under the contract.

2) The Contractor will accept as its operating policy the following statement:

"It is the policy of this Company to assure that applicants are employed, and that employees are treated during employment, without regard to their race, religion, sex, color, national origin, age or disability. Such action shall include: employment, upgrading, demotion, or transfer; recruitment or recruitment advertising; layoff or termination; rates of pay or other forms of compensation; and selection for training, including apprenticeship, pre-apprenticeship, and/or on-the-job training."

B. EEO Officer: The Contractor will designate and make known to the contracting officers an EEO Officer who will have the responsibility for and must be capable of effectively administering and promoting an active EEO program and who must be assigned adequate authority and responsibility to do so.

C. Dissemination of Policy: All members of the Contractor's staff who are authorized to hire, supervise, promote, and discharge employees, or who recommend such action, or who are substantially involved in such action, will be made fully cognizant of, and will implement, the Contractor's EEO policy and contractual responsibilities to provide EEO in each grade and classification of employment. To ensure that the above agreement will be met, the following actions will be taken as a minimum:

1) Periodic meetings of supervisory and personnel office employees will be conducted before the start of work and then not less often than once every six months, at which time the Contractor's EEO policy and its implementation will be reviewed and explained. The meetings will be conducted by the EEO Officer.

2) All new supervisory or personnel office employees will be given a thorough indoctrination by the EEO Officer, covering all major aspects of the Contractor's EEO obligations within thirty days following their reporting for duty with the Contractor.

3) All personnel who are engaged in direct recruitment for the project will be instructed by the EEO Officer in the Contractor's procedures for locating and hiring minorities and women.

4) Notices and posters setting forth the Contractor's EEO policy will be placed in areas readily accessible to employees, applicants for employment and potential employees.

5) The Contractor's EEO policy and the procedures to implement such policy will be brought to the attention of employees by means of meetings, employee handbooks, or other appropriate means.

D. Recruitment: When advertising for employees, the Contractor will include in all advertisements for employees the notation: "An Equal Opportunity Employer." All such advertisements will be placed in publications having a large circulation among minorities and women in the area from which the project work force would normally be derived.

1) The Contractor will, unless precluded by a valid bargaining agreement, conduct systematic and direct recruitment through public and private employee referral sources likely to yield qualified minorities and women. To meet this requirement, the Contractor will identify sources of potential minority group employees, and establish with such identified sources procedures whereby minority and women applicants may be referred to the Contractor for employment consideration.

2) In the event the Contractor has a valid bargaining agreement providing for exclusive hiring hall referrals, the Contractor is expected to observe the provisions of that agreement to the extent that the system meets the Contractor's compliance with EEO contract provisions. Where implementation of such an agreement has the effect of discriminating against minorities or women, or obligates the Contractor to do the same, such implementation violates Federal nondiscrimination provisions.

3) The Contractor will encourage its present employees to refer minorities and women as applicants for employment. Information and procedures with regard to referring such applicants will be discussed with employees.

E. Personnel Actions: Wages, working conditions, and employee benefits shall be established and administered, and personnel actions of every type, including hiring, upgrading, promotion, transfer, demotion, layoff, and termination, shall be taken without regard to race, color, religion, sex, national origin, age or disability. The following procedures shall be followed:

- 1) The Contractor will conduct periodic inspections of project sites to insure that working conditions and employee facilities do not indicate discriminatory treatment of project site personnel.
- 2) The Contractor will periodically evaluate the spread of wages paid within each classification to determine any evidence of discriminatory wage practices.
- 3) The Contractor will periodically review selected personnel actions in depth to determine whether there is evidence of discrimination. Where evidence is found, the Contractor will promptly take corrective action. If the review indicates that the discrimination may extend beyond the actions reviewed, such corrective action shall include all affected persons.
- 4) The Contractor will promptly investigate all complaints of alleged discrimination made to the Contractor in connection with its obligations under this Agreement, will attempt to resolve such complaints, and will take appropriate corrective action within a reasonable time. If the investigation indicates that the discrimination may affect persons other than the complainant, such corrective action shall include such other persons. Upon completion of each investigation, the Contractor will inform every complainant of all of their avenues of appeal.

F. Training and Promotion:

- 1) The Contractor will assist in locating, qualifying, and increasing the skills of minorities and women who are applicants for employment or current employees. Such efforts should be aimed at developing full journey level status employees in the type of trade or job classification involved.
- 2) Consistent with the Contractor's work force requirements and as permissible under Federal and State regulations, the Contractor shall make full use of training programs, i.e., apprenticeship, and on-the-job training programs for the geographical area of contract performance. In the event a special provision for training is provided under this Agreement, this subparagraph will be superseded as indicated in the special provision. the PAG may reserve training positions for persons who receive welfare assistance in accordance with 23 U.S.C. 140(a).
- 3) The Contractor will advise employees and applicants for employment of available training programs and entrance requirements for each.
- 4) The Contractor will periodically review the training and promotion potential of employees who are minorities and women and will encourage eligible employees to apply for such training and promotion.

G. Unions: If the Contractor relies in whole or in part upon unions as a source of employees, the Contractor will use good faith efforts to obtain the cooperation of such unions to increase opportunities for minorities and women. Actions by the Contractor, either directly or through a contractor's association acting as agent, will include the procedures set forth below:

- 1) The Contractor will use good faith efforts to develop, in cooperation with the unions, joint training programs aimed toward qualifying more minorities and women for membership in the unions and increasing the skills of minorities and women so that they may qualify for higher paying employment.
- 2) The Contractor will use good faith efforts to incorporate an EEO clause into each union agreement to the end that such union will be contractually bound to refer applicants without regard to their race, color, religion, sex, national origin, age or disability.
- 3) The Contractor is to obtain information as to the referral practices and policies of the labor union except that to the extent such information is within the exclusive possession of the labor union and such labor union refuses to furnish such information to the Contractor, the Contractor shall so certify to the PAG and shall set forth what efforts have been made to obtain such information.
- 4) In the event the union is unable to provide the Contractor with a reasonable flow of referrals within the time limit set forth in the collective bargaining agreement, the Contractor will, through independent recruitment efforts, fill the employment vacancies without regard to race, color, religion, sex, national origin, age or disability; making full efforts to obtain qualified and/or qualifiable minorities and women. The failure of a union to provide sufficient referrals (even though it is obligated to provide exclusive referrals under the terms of a collective bargaining agreement) does not relieve the Contractor from the requirements of this paragraph. In the event the union referral practice prevents the Contractor from meeting the obligations pursuant to Executive Order 11246, as amended, and these special provisions, the Contractor shall immediately notify the PAG.

H. Reasonable Accommodation for Applicants/Employees with Disabilities: The Contractor must be familiar with the requirements for and comply with the Americans with Disabilities Act and all rules and regulations established thereunder. Employers must provide reasonable accommodation in all employment activities unless to do so would cause an undue hardship.

I. Selection of Subcontractors, Procurement of Materials and Leasing of Equipment: The Contractor shall not discriminate on the grounds of race, color, religion, sex, national origin, age or disability in the selection and retention of subcontractors, including procurement of materials and leases of equipment. The Contractor shall take all necessary and reasonable steps to ensure nondiscrimination in the administration of this Agreement.

1) The Contractor shall notify all potential subcontractors and suppliers and lessors of their EEO obligations under this Agreement.

2) The Contractor will use good faith efforts to ensure subcontractor compliance with their EEO obligations.

J. Records and Reports: The Contractor shall keep such records as necessary to document compliance with the EEO requirements. Such records shall be retained for a period of three years following the date of the final payment to the Contractor for all the Work under this Agreement and shall be available at reasonable times and places for inspection by authorized representatives of the PAG.

1) The records kept by the Contractor shall document the following:

- (a) The number and work hours of minority and non-minority group members and women employed in each work classification on the project;
- (b) The progress and efforts being made in cooperation with unions, when applicable, to increase employment opportunities for minorities and women; and
- (c) The progress and efforts being made in locating, hiring, training, qualifying, and upgrading minorities and women;

2) The Contractor and any subcontractors will submit an annual report to the PAG each July for the duration of the Project, indicating the number of minority, women, and non-minority group employees currently engaged in each work classification required by the Work under this Agreement. The staffing data should represent the project work force on board in all or any part of the last payroll period preceding the end of July. If on-the-job training is being required by special provision, the Contractor will be required to collect and report training data. The employment data should reflect the work force on board during all or any part of the last payroll period preceding the end of July.

NONSEGREGATED FACILITIES
(APPLICABLE TO ALL CONSTRUCTION CONTRACTS AND SUBCONTRACTS)

The Contractor must ensure that facilities provided for employees are provided in such a manner that segregation on the basis of race, color, religion, sex, or national origin cannot result. The Contractor may neither require such segregated use by written or oral policies nor tolerate such use by employee custom. The Contractor's obligation extends further to ensure that its employees are not assigned to perform their services at any location, under the Contractor's control, where the facilities are segregated. The term "facilities" includes waiting rooms, work areas, restaurants and other eating areas, time clocks, restrooms, washrooms, locker rooms, and other storage or dressing areas, parking lots, drinking fountains, recreation or entertainment areas, transportation, and housing provided for employees. The Contractor shall provide separate or single-user restrooms and necessary dressing or sleeping areas to assure privacy between sexes.

DAVIS-BACON ACT COMPLIANCE
(APPLICABLE TO ALL CONSTRUCTION CONTRACTS AND SUBCONTRACTS EXCEEDING \$2,000)

A. **Minimum wages**

1) All laborers and mechanics employed or working upon the site of the work, will be paid unconditionally and not less often than once a week, and without subsequent deduction or rebate on any account (except such payroll deductions as are permitted by regulations issued by the Secretary of Labor under the Copeland Act (29 CFR part 3)), the full amount of wages and bona fide fringe benefits (or cash equivalents thereof) due at time of payment computed at rates not less than those contained in the wage determination of the Secretary of Labor which is attached hereto and made a part hereof, regardless of any contractual relationship which may be alleged to exist between the Contractor and such laborers and mechanics.

Contributions made or costs reasonably anticipated for bona fide fringe benefits under section 1(b)(2) of the Davis-Bacon Act on behalf of laborers or mechanics are considered wages paid to such laborers or mechanics, subject to the provisions of paragraph 1.d. of this section; also, regular contributions made or costs incurred for more than a weekly period (but not less often than quarterly) under plans, funds, or programs which cover the

particular weekly period, are deemed to be constructively made or incurred during such weekly period. Such laborers and mechanics shall be paid the appropriate wage rate and fringe benefits on the wage determination for the classification of work actually performed, without regard to skill, except as provided in 29 CFR 5.5(a)(4). Laborers or mechanics performing work in more than one classification may be compensated at the rate specified for each classification for the time actually worked therein: Provided, That the employer's payroll records accurately set forth the time spent in each classification in which work is performed. The wage determination (including any additional classification and wage rates conformed under paragraph 1.b. of this section) and the Davis-Bacon poster (WH-1321) shall be posted at all times by the Contractor and its subcontractors at the site of the work in a prominent and accessible place where it can be easily seen by the workers.

2) The contracting officer shall require that any class of laborers or mechanics, including helpers, which is not listed in the wage determination and which is to be employed under the contract shall be classified in conformance with the wage determination. The contracting officer shall approve an additional classification and wage rate and fringe benefits therefore only when the following criteria have been met:

- (i) The work to be performed by the classification requested is not performed by a classification in the wage determination; and
- (ii) The classification is utilized in the area by the construction industry; and
- (iii) The proposed wage rate, including any bona fide fringe benefits, bears a reasonable relationship to the wage rates contained in the wage determination.

3) If the Contractor and the laborers and mechanics to be employed in the classification (if known), or their representatives, and the contracting officer agree on the classification and wage rate (including the amount designated for fringe benefits where appropriate), a report of the action taken shall be sent by the contracting officer to the Administrator of the Wage and Hour Division, Employment Standards Administration, U.S. Department of Labor, Washington, DC 20210. The Administrator, or an authorized representative, will approve, modify, or disapprove every additional classification action within 30 days of receipt and so advise the contracting officer or will notify the contracting officer within the 30-day period that additional time is necessary.

4) In the event the Contractor, the laborers or mechanics to be employed in the classification or their representatives, and the contracting officer do not agree on the proposed classification and wage rate (including the amount designated for fringe benefits, where appropriate), the contracting officer shall refer the questions, including the views of all interested parties and the recommendation of the contracting officer, to the Wage and Hour Administrator for determination. The Wage and Hour Administrator, or an authorized representative, will issue a determination within 30 days of receipt and so advise the contracting officer or will notify the contracting officer within the 30-day period that additional time is necessary.

5) The wage rate (including fringe benefits where appropriate) determined pursuant to paragraphs 1.b.(2) or 1.b.(3) of this section, shall be paid to all workers performing work in the classification under this contract from the first day on which work is performed in the classification.

6) Whenever the minimum wage rate prescribed in the contract for a class of laborers or mechanics includes a fringe benefit which is not expressed as an hourly rate, the Contractor shall either pay the benefit as stated in the wage determination or shall pay another bona fide fringe benefit or an hourly cash equivalent thereof.

7) If the Contractor does not make payments to a trustee or other third person, the Contractor may consider as part of the wages of any laborer or mechanic the amount of any costs reasonably anticipated in providing bona fide fringe benefits under a plan or program, Provided, That the Secretary of Labor has found, upon the written request of the Contractor, that the applicable standards of the Davis-Bacon Act have been met. The Secretary of Labor may require the Contractor to set aside, in a separate account, assets for the meeting of obligations under the plan or program.

B. Withholding

The contracting agency shall upon its own action or upon written request of an authorized representative of the Department of Labor, withhold or cause to be withheld from the Contractor under this contract, or any other Federal contract with the same prime Contractor, or any other federally-assisted contract subject to Davis-Bacon prevailing wage requirements, which is held by the same prime Contractor, so much of the accrued payments or advances as may be considered necessary to pay laborers and mechanics, including apprentices, trainees, and helpers, employed by the Contractor or any subcontractor the full amount of wages required by the contract. In the event of failure to pay any laborer or mechanic, including any apprentice, trainee, or helper, employed or working on the site of the work, all or part of the wages required by the contract, the PAG may, after written

notice to the Contractor, take such action as may be necessary to cause the suspension of any further payment, advance, or guarantee of funds until such violations have ceased.

C. Payrolls and Basic Records

1) Payrolls and basic records relating thereto shall be maintained by the Contractor during the course of the work and preserved for a period of three years thereafter for all laborers and mechanics working at the site of the work. Such records shall contain the name, address, and social security number of each such worker, his or her correct classification, hourly rates of wages paid (including rates of contributions or costs anticipated for bona fide fringe benefits or cash equivalents thereof of the types described in section 1(b)(2)(B) of the Davis-Bacon Act), daily and weekly number of hours worked, deductions made and actual wages paid. Whenever the Secretary of Labor has found under 29 CFR 5.5(a)(1)(iv) that the wages of any laborer or mechanic include the amount of any costs reasonably anticipated in providing benefits under a plan or program described in section 1(b)(2)(B) of the Davis-Bacon Act, the Contractor shall maintain records which show that the commitment to provide such benefits is enforceable, that the plan or program is financially responsible, and that the plan or program has been communicated in writing to the laborers or mechanics affected, and records which show the costs anticipated or the actual cost incurred in providing such benefits. Contractors employing apprentices or trainees under approved programs shall maintain written evidence of the registration of apprenticeship programs and certification of trainee programs, the registration of the apprentices and trainees, and the ratios and wage rates prescribed in the applicable programs.

2) The Contractor shall submit weekly for each week in which any contract work is performed a copy of all payrolls to the PAG. The payrolls submitted shall set out accurately and completely all of the information required to be maintained under 29 CFR 5.5(a)(3)(i), except that full social security numbers and home addresses shall not be included on weekly transmittals. Instead the payrolls shall only need to include an individually identifying number for each employee (e.g., the last four digits of the employee's social security number). The required weekly payroll information may be submitted in any form desired. Optional Form WH-347 is available for this purpose from the Wage and Hour Division Web site at <http://www.dol.gov/esa/whd/forms/wh347instr.htm> or its successor site. The prime Contractor is responsible for the submission of copies of payrolls by all subcontractors. Contractors and subcontractors shall maintain the full social security number and current address of each covered worker, and shall provide them upon request to the PAG for transmission to the Wage and Hour Division of the Department of Labor for purposes of an investigation or audit of compliance with prevailing wage requirements. It is not a violation of this section for a prime contractor to require a subcontractor to provide addresses and social security numbers to the prime contractor for its own records, without weekly submission to the PAG.

3) Each payroll submitted shall be accompanied by a "Statement of Compliance," signed by the Contractor or subcontractor or his or her agent who pays or supervises the payment of the persons employed under the contract and shall certify the following:

- (i) That the payroll for the payroll period contains the information required to be provided under §5.5(a)(3)(ii) of Regulations, 29 CFR part 5, the appropriate information is being maintained under §5.5(a)(3)(i) of Regulations, 29 CFR part 5, and that such information is correct and complete;
- (ii) That each laborer or mechanic (including each helper, apprentice, and trainee) employed on the contract during the payroll period has been paid the full weekly wages earned, without rebate, either directly or indirectly, and that no deductions have been made either directly or indirectly from the full wages earned, other than permissible deductions as set forth in Regulations, 29 CFR part 3;
- (iii) That each laborer or mechanic has been paid not less than the applicable wage rates and fringe benefits or cash equivalents for the classification of work performed, as specified in the applicable wage determination incorporated into the contract.

4) The weekly submission of a properly executed certification set forth on the reverse side of Optional Form WH-347 shall satisfy the requirement for submission of the "Statement of Compliance" required by paragraph 3.b.(2) of this section.

5) The falsification of any of the above certifications may subject the Contractor or subcontractor to civil or criminal prosecution under section 1001 of title 18 and section 231 of title 31 of the United States Code.

6) The Contractor or subcontractor shall make the records required under this section available for inspection, copying, or transcription by authorized representatives of the contracting agency or the Department of Labor, and shall permit such representatives to interview employees during working hours on the job. If the Contractor or subcontractor fails to submit the required records or to make them available, the Federal granting agency may, after written notice to the Contractor, or the contracting agency, take such action as may be necessary to cause the suspension of any further payment, advance, or guarantee of funds. Furthermore, failure to submit the required

records upon request or to make such records available may be grounds for debarment action pursuant to 29 CFR 5.12.

D. Apprentices and trainees

1) Apprentices (programs of the USDOL).

Apprentices will be permitted to work at less than the predetermined rate for the work they performed when they are employed pursuant to and individually registered in a bona fide apprenticeship program registered with the U.S. Department of Labor, Employment and Training Administration, Office of Apprenticeship Training, Employer and Labor Services, or with a State Apprenticeship Agency recognized by the Office, or if a person is employed in his or her first 90 days of probationary employment as an apprentice in such an apprenticeship program, who is not individually registered in the program, but who has been certified by the Office of Apprenticeship Training, Employer and Labor Services or a State Apprenticeship Agency (where appropriate) to be eligible for probationary employment as an apprentice.

The allowable ratio of apprentices to journeymen on the job site in any craft classification shall not be greater than the ratio permitted to the Contractor as to the entire work force under the registered program. Any worker listed on a payroll at an apprentice wage rate, who is not registered or otherwise employed as stated above, shall be paid not less than the applicable wage rate on the wage determination for the classification of work actually performed. In addition, any apprentice performing work on the job site in excess of the ratio permitted under the registered program shall be paid not less than the applicable wage rate on the wage determination for the work actually performed. Where a contractor is performing construction on a project in a locality other than that in which its program is registered, the ratios and wage rates (expressed in percentages of the journeyman's hourly rate) specified in the Contractor's or subcontractor's registered program shall be observed.

Every apprentice must be paid at not less than the rate specified in the registered program for the apprentice's level of progress, expressed as a percentage of the journeymen hourly rate specified in the applicable wage determination. Apprentices shall be paid fringe benefits in accordance with the provisions of the apprenticeship program. If the apprenticeship program does not specify fringe benefits, apprentices must be paid the full amount of fringe benefits listed on the wage determination for the applicable classification. If the Administrator determines that a different practice prevails for the applicable apprentice classification, fringes shall be paid in accordance with that determination.

In the event the Office of Apprenticeship Training, Employer and Labor Services, or a State Apprenticeship Agency recognized by the Office, withdraws approval of an apprenticeship program, the Contractor will no longer be permitted to utilize apprentices at less than the applicable predetermined rate for the work performed until an acceptable program is approved.

2) Trainees (programs of the USDOL).

Except as provided in 29 CFR 5.16, trainees will not be permitted to work at less than the predetermined rate for the work performed unless they are employed pursuant to and individually registered in a program which has received prior approval, evidenced by formal certification by the U.S. Department of Labor, Employment and Training Administration.

The ratio of trainees to journeymen on the job site shall not be greater than permitted under the plan approved by the Employment and Training Administration.

Every trainee must be paid at not less than the rate specified in the approved program for the trainee's level of progress, expressed as a percentage of the journeyman hourly rate specified in the applicable wage determination. Trainees shall be paid fringe benefits in accordance with the provisions of the trainee program. If the trainee program does not mention fringe benefits, trainees shall be paid the full amount of fringe benefits listed on the wage determination unless the Administrator of the Wage and Hour Division determines that there is an apprenticeship program associated with the corresponding journeyman wage rate on the wage determination which provides for less than full fringe benefits for apprentices. Any employee listed on the payroll at a trainee rate who is not registered and participating in a training plan approved by the Employment and Training Administration shall be paid not less than the applicable wage rate on the wage determination for the classification of work actually performed. In addition, any trainee performing work on the job site in excess of the ratio permitted under the registered program shall be paid not less than the applicable wage rate on the wage determination for the work actually performed.

In the event the Employment and Training Administration withdraws approval of a training program, the Contractor will no longer be permitted to utilize trainees at less than the applicable predetermined rate for the work performed until an acceptable program is approved.

3) Equal employment opportunity. The utilization of apprentices, trainees and journeymen under this part shall be in conformity with the equal employment opportunity requirements of Executive Order 11246, as amended, and 29 CFR part 30.

E. Compliance with Copeland Act requirements. The Contractor shall comply with the requirements of 29 CFR part 3, which are incorporated by reference in this contract.

F. Subcontracts. The Contractor or subcontractor shall insert in any subcontracts the clauses contained in 29 CFR 5.5(a)(1) through (10) and such other clauses as the (write in the name of the Federal agency) may by appropriate instructions require, and also a clause requiring the subcontractors to include these clauses in any lower tier subcontracts. The prime Contractor shall be responsible for the compliance by any subcontractor or lower tier subcontractor with all the contract clauses in 29 CFR 5.5.

G. Contract termination: debarment. A breach of the contract clauses in 29 CFR 5.5 may be grounds for termination of the contract, and for debarment as a contractor and a subcontractor as provided in 29 CFR 5.12.

H. Compliance with Davis-Bacon and Related Act requirements. All rulings and interpretations of the Davis-Bacon and Related Acts contained in 29 CFR parts 1, 3, and 5 are herein incorporated by reference in this contract.

I. Disputes concerning labor standards. Disputes arising out of the labor standards provisions of this contract shall not be subject to the general disputes clause of this contract. Such disputes shall be resolved in accordance with the procedures of the Department of Labor set forth in 29 CFR parts 5, 6, and 7. Disputes within the meaning of this clause include disputes between the Contractor (or any of its subcontractors) and the PAG, the U.S. Department of Labor, or the employees or their representatives.

J. Certification of eligibility.

1) By entering into this contract, the Contractor certifies that neither it (nor he or she) nor any person or firm who has an interest in the Contractor's firm is a person or firm ineligible to be awarded Government contracts by virtue of section 3(a) of the Davis-Bacon Act or 29 CFR 5.12(a)(1).

2) No part of this contract shall be subcontracted to any person or firm ineligible for award of a Government contract by virtue of section 3(a) of the Davis-Bacon Act or 29 CFR 5.12(a)(1).

3) The penalty for making false statements is prescribed in the U.S. Criminal Code, 18 U.S.C. 1001.

CONTRACT WORK HOURS AND SAFETY STANDARDS ACT
(APPLICABLE TO ALL CONTRACTS AND SUBCONTRACTS EXCEEDING \$100,000 AND INVOLVING EMPLOYMENT OF MECHANICS AND LABORERS)

As used in these paragraphs, the terms laborers and mechanics include watchmen and guards.

A. Overtime requirements. No contractor or subcontractor contracting for any part of the contract Work which may require or involve the employment of laborers or mechanics shall require or permit any such laborer or mechanic in any workweek in which he or she is employed on such work to work in excess of forty hours in such workweek unless such laborer or mechanic receives compensation at a rate not less than one and one-half times the basic rate of pay for all hours worked in excess of forty hours in such workweek.

B. Violation; liability for unpaid wages; liquidated damages. In the event of any violation of this section, the Contractor and any subcontractor responsible therefore shall be liable for the unpaid wages. In addition, such Contractor and subcontractor shall be liable to the United States (in the case of work done under contract for the District of Columbia or a territory, to such District or to such territory), for liquidated damages. Such liquidated damages shall be computed with respect to each individual laborer or mechanic, including watchmen and guards, employed in violation of the clause set forth in this section, in the sum of \$10 for each calendar day on which such individual was required or permitted to work in excess of the standard workweek of forty hours without payment of the overtime wages required by this section.

C. Withholding for unpaid wages and liquidated damages. the PAG shall upon its own action or upon written request of an authorized representative of the Department of Labor withhold or cause to be withheld, from any moneys payable on account of work performed by the Contractor or subcontractor under any such contract or any other Federal contract with the same prime Contractor, or any other federally-assisted contract subject to the Contract Work Hours and Safety Standards Act, which is held by the same prime Contractor, such sums as

may be determined to be necessary to satisfy any liabilities of such Contractor or subcontractor for unpaid wages and liquidated damages as provided in the clause set forth in this section.

D. Subcontracts. The Contractor or subcontractor shall insert in any subcontracts the clauses set forth in this section and also a clause requiring the subcontractors to include these clauses in any lower tier subcontracts. The prime Contractor shall be responsible for compliance by any subcontractor or lower tier subcontractor with the clauses set forth in this section.

SAFETY: ACCIDENT PREVENTION

(APPLICABLE TO ALL CONSTRUCTION CONTRACTS AND SUBCONTRACTS EXCEEDING \$100,000)

A. In the performance of this contract the Contractor shall comply with all applicable Federal, State, and local laws governing safety, health, and sanitation. The Contractor shall provide all safeguards, safety devices and protective equipment and take any other needed actions as it determines, or as the contracting officer may determine, to be reasonably necessary to protect the life and health of employees on the job and the safety of the public and to protect property in connection with the performance of the work covered by the contract.

B. It is a condition of this contract, and shall be made a condition of each subcontract, which the Contractor enters into pursuant to this contract, that the Contractor and any subcontractor shall not permit any employee, in performance of the contract, to work in surroundings or under conditions which are unsanitary, hazardous or dangerous to his/her health or safety, as determined under construction safety and health standards (29 CFR 1926) promulgated by the Secretary of Labor, in accordance with Section 107 of the Contract Work Hours and Safety Standards Act (40 U.S.C. 3704).

C. Pursuant to 29 CFR 1926.3, it is a condition of this contract that the Secretary of Labor or authorized representative thereof, shall have right of entry to any site of contract performance to inspect or investigate the matter of compliance with the construction safety and health standards and to carry out the duties of the Secretary under Section 107 of the Contract Work Hours and Safety Standards Act (40 U.S.C.3704).

D. Hazardous Materials.

(1) The Contractor is responsible for compliance with any applicable Federal, State, and local laws or requirements regarding hazardous materials. If the Contractor encounters a hazardous material or substance not addressed in this Agreement and if reasonable precautions will be inadequate to prevent foreseeable bodily injury or death to persons resulting from a material or substance, including but not limited to asbestos or polychlorinated biphenyl (PCB), encountered on the site by the Contractor, the Contractor shall, upon recognizing the condition, immediately stop Work in the affected area and report the condition to the PAG and the Project Manager in writing.

(2) The Contractor shall indemnify the PAG for the cost and expense incurred: (1) for remediation of a material or substance the Contractor brings to the site and negligently handles; or (2) where the Contractor fails to perform its obligations, except to the extent that the cost and expense are due to the PAG's fault or negligence.

E. **Emergencies.** In an emergency affecting safety of persons or property, the Contractor shall act, at the Contractor's discretion, to prevent threatened damage, injury or loss.

DRUG FREE WORKPLACE

A. The Contractor shall, within 30 days after award:

(1) Publish a statement notifying its employees that the unlawful manufacture, distribution, dispensing, possession, or use of a controlled substance is prohibited in the Contractor's workplace and specifying the actions that will be taken against employees for violations of such prohibition; (2) Establish an ongoing drug-free awareness program to inform such employees about -

(i) The dangers of drug abuse in the workplace;

(ii) The Contractor's policy of maintaining a drug-free workplace;

(iii) Any available drug counseling, rehabilitation, and employee assistance programs; and

(iv) The penalties that may be imposed upon employees for drug abuse violations occurring in the workplace.

(3) Provide all employees engaged in performance of the contract with a copy of the statement required by paragraph (1) of this clause;

(4) Notify such employees in writing in the statement required by subparagraph (b)(1) of this clause that, as a condition of continued employment on this contract, the employee will -

(i) Abide by the terms of the statement; and

(ii) Notify the employer in writing of the employee's conviction under a criminal drug statute for a violation occurring in the workplace no later than 5 days after such conviction.

(5) Notify the Procurement Officer in writing within 10 days after receiving notice under subdivision (4)(ii) of this clause, from an employee or otherwise receiving actual notice of such conviction. The notice shall include the position title of the employee;

(6) Within 30 days after receiving notice under subdivision (4)(ii) of this clause of a conviction, take one of the following actions with respect to any employee who is convicted of a drug abuse violation occurring in the workplace:

(i) Taking appropriate personnel action against such employee, up to and including termination; or

(ii) Require such employee to satisfactorily participate in a drug abuse assistance or rehabilitation program approved for such purposes by a Federal, State, or local health, law enforcement, or other appropriate agency; and

(7) Make a good faith effort to maintain a drug-free workplace through implementation of paragraphs (1) through (6) of this clause.

B. The Contractor, if an individual, agrees by award of the contract or acceptance of a purchase order, not to engage in the unlawful manufacture, distribution, dispensing, possession, or use of a controlled substance while performing this contract.

C. In addition to other remedies available to the PAG, the Contractor's failure to comply with the requirements of paragraph (B) or (C) of this clause may render the Contractor subject to suspension of contract payments, termination of the contract for default, and suspension or debarment.

RIGHTS TO INVENTIONS MADE UNDER A CONTRACT OR AGREEMENT
(APPLICABLE TO ALL CONTRACTS INVOLVING EXPERIMENTAL, DEVELOPMENTAL, OR RESEARCH WORK BY A SMALL BUSINESS ENTITY OR NON-PROFIT ENTITY)

A. The Contractor must comply with all applicable requirements of 37 CFR Part 401, "Rights to Inventions Made by Nonprofit Organizations and Small Business Firms Under Government Grants, Contracts and Cooperative Agreements," and any implementing regulations issued by the OEA. The interpretation of this clause and this Agreement is subject to the definitions located at 37 CFR § 401.14.

B. The Contractor may retain the entire right, title, and interest throughout the world to each subject invention subject to the provisions of this clause and 35 U.S.C. 203. With respect to any subject invention in which the Contractor retains title, the Federal government shall have a nonexclusive, nontransferable, irrevocable, paid-up license to practice or have practiced for or on behalf of the United States the subject invention throughout the world.

C. **Invention Disclosure, Election of Title and Filing of Patent Application by Contractor**

1. The Contractor will disclose each subject invention to the OEA ("Federal Agency") within two months after the inventor discloses it in writing to Contractor personnel responsible for patent matters. The disclosure to the agency shall be in the form of a written report and shall identify the contract under which the invention was made and the inventor(s). It shall be sufficiently complete in technical detail to convey a clear understanding to the extent known at the time of the disclosure, of the nature, purpose, operation, and the physical, chemical, biological or electrical characteristics of the invention. The disclosure shall also identify any publication, on sale or public use of the invention and whether a manuscript describing the invention has been submitted for publication and, if so, whether it has been accepted for publication at the time of disclosure. In addition, after disclosure to the agency, the Contractor will promptly notify the agency of the acceptance of any manuscript describing the invention for publication or of any on sale or public use planned by the Contractor.

2. The Contractor will elect in writing whether or not to retain title to any such invention by notifying the Federal agency within two years of disclosure to the Federal agency. However, in any case where a patent, a printed publication, public use, sale, or other availability to the public has initiated the one year statutory period wherein valid patent protection can still be obtained in the United States, the period for election of title may be shortened by the agency to a date that is no more than 60 days prior to the end of the statutory period.

3. The Contractor will file its initial patent application on a subject invention to which it elects to retain title within one year after election of title or, if earlier, prior to the end of any statutory period wherein valid patent protection can be obtained in the United States after a publication, on sale, or public use. If the Contractor files a provisional application as its initial patent application, it shall file a non-provisional application within 10 months of the filing of the provisional application. The Contractor will file patent applications in additional countries or International patent offices within either ten months of the first filed patent application or six months from the date permission is granted by the Commissioner of Patents to file foreign patent applications where such filing has been prohibited by a Secrecy Order.

4. For any subject invention with Federal agency and Contractor co-inventors, where the Federal agency employing such co-inventor determines that it would be in the interest of the government, pursuant to 35

U.S.C. 207(a)(3), to file an initial patent application on the subject invention, the Federal agency employing such co-inventor, at its discretion and in consultation with the Contractor, may file such application at its own expense, provided that the Contractor retains the ability to elect title pursuant to 35 U.S.C. 202(a).

5. Requests for extension of the time for disclosure, election, and filing under paragraphs (1), (2), and (3) of this clause may, at the discretion of the Federal agency, be granted. When a Contractor has requested an extension for filing a non-provisional application after filing a provisional application, a one-year extension will be granted unless the Federal agency notifies the Contractor within 60 days of receiving the request.

D. Conditions When the Government May Obtain Title

The Contractor will convey to the Federal agency, upon written request, title to any subject invention:

1. If the Contractor fails to disclose or elect title to the subject invention within the times specified in paragraph (C) of this clause, or elects not to retain title.

2. In those countries in which the Contractor fails to file patent applications within the times specified in paragraph (C) of this clause; provided, however, that if the Contractor has filed a patent application in a country after the times specified in paragraph (C) of this clause, but prior to its receipt of the written request of the Federal agency, the Contractor shall continue to retain title in that country.

3. In any country in which the Contractor decides not to continue the prosecution of any non-provisional patent application for, to pay a maintenance, annuity or renewal fee on, or to defend in a reexamination or opposition proceeding on, a patent on a subject invention.

E. Minimum Rights to Contractor and Protection of the Contractor Right to File

1. The Contractor will retain a nonexclusive royalty-free license throughout the world in each subject invention to which the Government obtains title, except if the Contractor fails to disclose the invention within the times specified in (C), above. The Contractor's license extends to its domestic subsidiary and affiliates, if any, within the corporate structure of which the Contractor is a party and includes the right to grant sublicenses of the same scope to the extent the Contractor was legally obligated to do so at the time the contract was awarded. The license is transferable only with the approval of the Federal agency except when transferred to the successor of that party of the Contractor's business to which the invention pertains.

2. The Contractor's domestic license may be revoked or modified by the funding Federal agency to the extent necessary to achieve expeditious practical application of the subject invention pursuant to an application for an exclusive license submitted in accordance with applicable provisions at 37 CFR part 404 and agency licensing regulations (if any). This license will not be revoked in that field of use or the geographical areas in which the Contractor has achieved practical application and continues to make the benefits of the invention reasonably accessible to the public. The license in any foreign country may be revoked or modified at the discretion of the funding Federal agency to the extent the Contractor, its licensees, or the domestic subsidiaries or affiliates have failed to achieve practical application in that foreign country.

3. Before revocation or modification of the license, the funding Federal agency will furnish the Contractor a written notice of its intention to revoke or modify the license, and the Contractor will be allowed thirty days (or such other time as may be authorized by the funding Federal agency for good cause shown by the Contractor) after the notice to show cause why the license should not be revoked or modified. The Contractor has the right to appeal, in accordance with applicable regulations in 37 CFR part 404 and agency regulations (if any) concerning the licensing of Government-owned inventions, any decision concerning the revocation or modification of the license.

F. Contractor Action to Protect the Government's Interest

1. The Contractor agrees to execute or to have executed and promptly deliver to the Federal agency all instruments necessary to: (i) establish or confirm the rights the Government has throughout the world in those subject inventions to which the Contractor elects to retain title; and (ii) convey title to the Federal agency when requested under paragraph (D) above and to enable the government to obtain patent protection throughout the world in that subject invention.

2. The Contractor agrees to require, by written agreement, its employees, other than clerical and nontechnical employees, to disclose promptly in writing to personnel identified as responsible for the administration of patent matters and in a format suggested by the Contractor each subject invention made under contract in order that the Contractor can comply with the disclosure provisions of paragraph (C) of this clause, to assign to the Contractor the entire right, title and interest in and to each subject invention made under contract, and to execute all papers necessary to file patent applications on subject inventions and to establish the government's rights in the subject inventions. This disclosure format should require, as a minimum, the information required by paragraph (C)(1) of this clause. The Contractor shall instruct such employees through employee agreements or other suitable educational programs on the importance of reporting inventions in sufficient time to permit the filing of patent applications prior to U.S. or foreign statutory bars.

3. For each subject invention, the Contractor will, no less than 60 days prior to the expiration of the statutory deadline, notify the Federal agency of any decision: Not to continue the prosecution of a non-provisional patent application; not to pay a maintenance, annuity or renewal fee; not to defend in a reexamination or opposition proceeding on a patent, in any country; to request, be a party to, or take action in a trial proceeding before the Patent Trial and Appeals Board of the U.S. Patent and Trademark Office, including but not limited to

post-grant review, review of a business method patent, *inter partes* review, and derivation proceeding; or to request, be a party to, or take action in a non-trial submission of art or information at the U.S. Patent and Trademark Office, including but not limited to a pre-issuance submission, a post-issuance submission, and supplemental examination.

4. The Contractor agrees to include, within the specification of any United States patent applications and any patent issuing thereon covering a subject invention, the following statement, "This invention was made with government support under the Agreement for Professional Technical Advisory Services between Contractor and OOG, awarded by the OOG under Federal Award Number HQ0005171035. The government has certain rights in the invention."

G. Subcontracts

1. The Contractor will include this clause, suitably modified to identify the parties, in all subcontracts, regardless of tier, for experimental, developmental or research work to be performed by a subcontractor. The subcontractor will retain all rights provided for the Contractor in this clause, and the Contractor will not, as part of the consideration for awarding the subcontract, obtain rights in the subcontractor's subject inventions.

2. The Contractor will include in all other subcontracts, regardless of tier, for experimental developmental or research work the patent rights clause required by the FAR or the Terms and Conditions of Federal Award Number HQ0005171035.

3. In the case of subcontracts, at any tier, when the prime award with the Federal agency was a contract (but not a grant or cooperative agreement), the OEA, subcontractor, and the Contractor agree that the mutual obligations of the parties created by this clause constitute a contract between the subcontractor and the Federal agency with respect to the matters covered by the clause; provided, however, that nothing in this paragraph is intended to confer any jurisdiction under the Contract Disputes Act in connection with proceedings under paragraph (J) of this clause.

H. Reporting on Utilization of Subject Inventions

The Contractor agrees to submit on request periodic reports no more frequently than annually on the utilization of a subject invention or on efforts at obtaining such utilization that are being made by the Contractor or its licensees or assignees. Such reports shall include information regarding the status of development, date of first commercial sale or use, gross royalties received by the Contractor, and such other data and information as the agency may reasonably specify. The Contractor also agrees to provide additional reports as may be requested by the agency in connection with any march-in proceeding undertaken by the agency in accordance with paragraph (J) of this clause. As required by 35 U.S.C. 202(c)(5), the agency agrees it will not disclose such information to persons outside the government without permission of the Contractor.

I. Preference for United States Industry

Notwithstanding any other provision of this clause, the Contractor agrees that neither it nor any assignee will grant to any person the exclusive right to use or sell any subject inventions in the United States unless such person agrees that any products embodying the subject invention or produced through the use of the subject invention will be manufactured substantially in the United States. However, in individual cases, the requirement for such an agreement may be waived by the Federal agency upon a showing by the Contractor or its assignee that reasonable but unsuccessful efforts have been made to grant licenses on similar terms to potential licensees that would be likely to manufacture substantially in the United States or that under the circumstances domestic manufacture is not commercially feasible.

J. March-in Rights

The Contractor agrees that with respect to any subject invention in which it has acquired title, the Federal agency has the right in accordance with the procedures in 37 CFR 401.6 and any supplemental regulations of the agency to require the Contractor, an assignee or exclusive licensee of a subject invention to grant a nonexclusive, partially exclusive, or exclusive license in any field of use to a responsible applicant or applicants, upon terms that are reasonable under the circumstances, and if the Contractor, assignee, or exclusive licensee refuses such a request the Federal agency has the right to grant such a license itself if the Federal agency determines that:

1. Such action is necessary because the Contractor or assignee has not taken, or is not expected to take within a reasonable time, effective steps to achieve practical application of the subject invention in such field of use.

2. Such action is necessary to alleviate health or safety needs which are not reasonably satisfied by the Contractor, assignee or their licensees;

3. Such action is necessary to meet requirements for public use specified by Federal regulations and such requirements are not reasonably satisfied by the Contractor, assignee or licensees; or

4. Such action is necessary because the agreement required by paragraph (I) of this clause has not been obtained or waived or because a licensee of the exclusive right to use or sell any subject invention in the United States is in breach of such agreement.

EXHIBIT B



PORT OF GUAM
 ATURIDAT I PUETTON GUAHAN
 Jose D. Leon Guerrero Commercial Port
 1026 Cabras Highway, Suite 201, Piti, Guam 96915
 Telephone: 671-477-5931/35 Facsimile: 671-477-2689/4445
 Website: www.portguam.com



Lourdes A. Leon Guerrero
 Governor of Guam
 Joshua F. Tenorio
 Lieutenant Governor

May 20, 2024

Patrick Chargualaf
 Generator and Equipment Sales
 Morrico Equipment
 197 Ypao Road
 Tamuning, GU 96913
 Tel: 671-649-1946

SUBJECT: Notice of Award for IFB # IFB-PAG-013-24
 Re-bid of 180' Telescopic Boom Lift

Dear Mr. Chargualaf,

This Notice of Award is issued in regard to the subject Invitation for Bids (IFB), issued by the Government of Guam, Port Authority of Guam for the 180' Telescopic Boom Lift. The Maintenance, Fleet, Procurement, and EQMR divisions have evaluated the bids received using the criteria identified in the IFB, and the Port Authority of Guam is hereby announcing its award to the following bidder:

Bidder	Bid Item No(s)	Total Amount
1 Federal Contracts Corp.	1.1	\$517,205.41

This award is conditioned upon the successful execution and final approval of the contract by all parties required by Guam law. This notice does not constitute the final formation of a contract between the Port and the successful Bidder. The successful Bidder shall not acquire any legal or equitable rights relative to the contract services until a contract containing terms and conditions acceptable to the Government of Guam is fully executed. The Port further reserves the right to cancel this Notice of Award at any time prior to the execution of a written contract in accordance with the provisions of the Guam Procurement Law and any other applicable laws or regulations.

Respectfully,



 Rory J. Respicio
 GENERAL MANAGER

ACKNOWLEDGEMENT	
Company:	Morrico Equipment
Name:	Patrick Chargualaf
Title:	Generator & Equipment Sales
Date/Time:	05/29/2024 at 4:38 PM

Patrick Chargualaf

May 29 2024

EXHIBIT C



OFFICE ☎ 671.649.1946 📠 671.649.1947
 PARTS 671.646.7914 671.646.7900

July 11/24
RECEIVED
 General Manager's Office
 Port Authority of Guam
July 11/24

June 3, 2024

Rory J. Respicio, General Manager
 Port Authority of Guam
 1026 Cabras Highway, Suite 201 Piti,
 Guam 96915

RE: Bid Protest of Port Authority of Guam IFB# IFB-PAG-013-24; Sunshine Act Request, page 1 of 2

Bid Protest

As you know, Morrigo Equipment LLC ("Morrigo") is a bidder who submitted an offer on IFB-PAG-013-24 (the "IFB"). The IFB is the Port Authority of Guam's (the "Port") rebid invitation seeking a 180' Telescopic Boom Lift. Morrigo was previously the lowest priced responsive bidder on the original iteration of this bid (IFB-PAG-004024) before the Port unilaterally decided to cancel that procurement and issue another for the exact same item.

On May 20, 2024, the Port informed Morrigo that, despite being the only fully responsive bidder to the IFB, the Port instead intended to enter into a contract with Federal Contracts Corp ("FCC"). The Port's May 20, 2024, decision constituted a mistake, as the Bid Abstract assembled by the Port's procurement team confirms that FCC not only failed to provide the bid security necessary for a responsive bid, but also fails to have the necessary business and other licenses needed to make sales to the Port. The Port's selection on May 20, 2024, of the FCC bid meant that the Port not only selected a non-responsive offeror to perform the work of the IFB, but also selected a party that could not responsibly perform under the laws of Guam the way that Morrigo can. The Port's apparent decision to select an offeror who provided no bid security also meant that FCC was provided with a *de facto* unfair pricing advantage that other offerors could not avail themselves of. Morrigo is compelled to submit this bid protest because of these failings in the Port procurement process.

Relief Requested

Morrigo requests that the Port correct its error, and determine that it cannot make an award to a bidder like FCC that failed to materially respond to all requirements of the IFB. More, the Port should determine that FCC is a non-responsible offeror, and that because of that fact an award cannot be made to FCC. Morrigo, as the next lowest priced responsive and responsible offeror, should be made the awardee of the IFB.

Automatic Stay

We understand this to be a pre-award procurement protest of IFB-PAG-013-24, and as such the protest serves as a statutory trigger for an Automatic Stay regarding the continued procurement of the IFB. Guam law mandates that the Port freeze this procurement in place, and shall not proceed further with the solicitation or with the award of the contract until this protest and all potential appeals are resolved. We look forward to the Port confirming this fact as we work together to resolve this protest.

TRASHCO GUAM DIESEL DELIVERY HEAVY EQUIPMENT

📍 197 Ypao Road, Tamuning Guam 96913 morrigoequipment.com



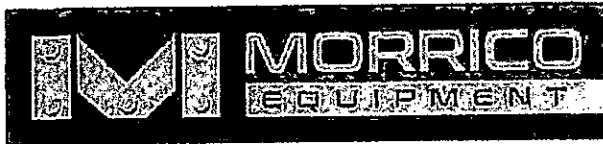

OFFICE ☎ 671.649.1946 📠 671.649.1947
PARTS ☎ 671.646.7914 📠 671.646.7900

RE: Bid Protest of Port Authority of Guam IFB# IFB-PAG-013-24; Sunshine Act Request, page 2 of 2

Sunshine Act Request

In addition to our Protest, Morrigo requests, in accordance with 5 G.C.A. § 10101, *et seq*, that the Port provide to the company the complete procurement record kept for the IFB, as well as any record associated with IFB-PAG-004024 and the decision to cancel that original bid process.

Morrigo has been honored to provide valued products and services in the past to the Port, as we look forward to finding an agreeable resolution to this Protest in as expeditious a manner as can be achieved so that the stay can be lifted, and the Port can receive the important lift it needs. Do not hesitate to contact me directly should you wish to discuss this matter.

Sincerely,

Joel Lesh – Executive VP / General Manager

☐ TRASHCO GUAM ☐ DIESEL DELIVERY ☐ HEAVY EQUIPMENT

📍 197 Ypao Road, Tamuning Guam 96913

🌐 morrigoequipment.com



EXHIBIT D



OFFICE ☎ 671.649.1946 📠 671.649.1947
 PARTS ☎ 671.646.7914 📠 671.646.7900

June 20, 2024

6/20/24 at 4:17pm
RECEIVED
 General Manager's Office
 Port Authority of Guam

Rory J. Respicio, General Manager
 Port Authority of Guam
 1026 Cabras Highway, Suite 201 Piti,
 Guam 96915

RE: Supplemental Bid Protest of Port Authority of Guam IFB# IFB-PAG-013-24

Bid Protest

As you know, Morrico Equipment LLC ("Morrico"), a bidder on IFB-PAG-013-24 (the "IFB"), has submitted a bid protest regarding the procurement that is currently being reviewed by the Port Authority of Guam (the "Port"). Morrico's June 3 protest was coupled with a 5 G.C.A. § 10101 Sunshine Act request that the Port provide to the company the complete procurement record kept for the IFB, as well as any record associated with IFB-PAG-004024 and the decision to cancel that original bid process. On June 5, 2024, PAG declined to comply with the Sunshine Act request, and instead invited Morrico to proceed to PAG to review the records there. Our team eventually did review the records, and that review has necessitated this protest supplement.

The procurement record review we recently undertook shows that Federal Contracts Corp ("FCC") was even more non-responsive than the Bid Abstract assembled by the Port's procurement team originally confirmed. Not only did FCC both fail to provide the bid security necessary for a responsive bid and fail to have the licenses necessary to do the work, their bid submission was non-responsive for a host of other reasons. Those failures are outlined as follows:

1. FCC failed to execute and provide the required Special Reminder to Prospective Bidders;
2. FCC failed execute and provide the Bid Bond form;
3. FCC was explicitly non-responsive in refusing to provide training as described and required on page 32 of the IFB;

TRASHCO GUAM DIESEL DELIVERY HEAVY EQUIPMENT

📍 197 Ypao Road, Tamuning Guam 96913 🌐 morricoequipment.com





OFFICE ☎ 671.649.1946 📠 671.649.1947
PARTS ☎ 671.646.7914 📠 671.646.7900

4. FCC refused to offer and provide the warranty required by the IFB;
5. FCC refused to offer and provide technical assistance as sought on page 33 of the IFB;
6. FCC refused to offer and provide service as required on page 33 of the IFB;
7. FCC does not have a local authorized dealer as required on page 33 of the IFB; and
8. FCC refused to provide complete familiarization training as required on page 33 of the IFB.

PAG's decision to accept the FCC offer despite its non-responsiveness, if left unaddressed, constitutes a fundamental and material change the specifications that only benefitted FCC, and left Morrigo and other potential bidders prejudiced by calculating and submitting bid prices that included cost items that FCC's bid did not account for. The Port's selection on May 20, 2024, of the FCC bid meant that the Port not only selected a non-responsive offeror who could not responsibly perform under the laws of Guam, but that the port also selected a non-responsive bidder that did not attempt to meet the same competitive bid hurdles that Morrigo was compelled to adhere to as a responsive offeror. The Port's acceptance of FCC's bid also meant that FCC's *de facto* unfair pricing advantage obtained by not submitting bid security was even greater since FCC was non-responsive on multiple aspects of bid performance.

Relief Requested

Morrigo requests that the Port correct its error, and determine that it cannot make an award to a bidder like FCC that failed to materially respond to all requirements of the IFB. More, the Port should determine that FCC is a non-responsible offeror, and that because of that fact an award cannot be made to FCC. Morrigo, as the next lowest priced responsive and responsible offeror, should be made the awardee of the IFB.

Automatic Stay

We understand this to be a supplement to an existing pre-award procurement protest of IFB-PAG-013-24, and as such the protest serves as a statutory trigger for an Automatic Stay regarding the continued procurement of the IFB. If necessary, PAG should consider this a second protest that must be addressed. Guam law mandates that the Port freeze this

TRASHCO GUAM DIESEL DELIVERY HEAVY EQUIPMENT

📍 197 Ypao Road, Tamuning Guam 96913 🌐 morrigoequipment.com





OFFICE ☎ 671.649.1946 📠 671.649.1947
PARTS ☎ 671.646.7914 📠 671.646.7900

procurement in place, and shall not proceed further with the solicitation or with the award of the contract until this protest and all potential appeals a

re resolved. We look forward to the Port confirming this fact as we work together to resolve this protest.

Morrigo continues to look forward to finding an agreeable resolution to these new Protest issues in as expeditious a manner as can be achieved so that the stay and be lifted, and the Port can receive the important lift it needs. Do not hesitate to contact me directly should you wish to discuss this matter.

Sincerely,

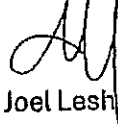
 for J.L.

Joel Lesh

General Manager

Morrigo Equipment

TRASHCO GUAM

DIESEL DELIVERY

HEAVY EQUIPMENT

📍 197 Ypao Road, Tamuning Guam 96913

🌐 morrigoequipment.com

An InScope Company

EXHIBIT E



PORT OF GUAM
ATURIDAT I PUETTON GUAHAN
Jose D. Leon Guerrero Commercial Port
1026 Cabras Highway, Suite 201, Piti, Guam 96915
Telephone: 671-477-5931/5 | Facsimile: 671-477-2689
Website: www.portofguam.com



Lourdes A. Leon Guerrero
Governor of Guam
Joshua F. Tenorio
Lieutenant Governor

TO: Joel Lesh, Executive VP/General Manager
VIA E-MAIL AND Joel.Lesh@MorricoEquipment.com
HAND DELIVERY: 197 Ypao Road, Tamuning, GU 96913
NAME: Morrico Equipment
DATE: July 31, 2024

RE: Decision on Protest submitted by Morrico Equipment on June 3, 2024, and its "Supplement to Protest" submitted on June 20, 2024, for Invitation for Bids IFB-PAG-013-24, re: Procurement of 180' Telescopic Boom Lift.

DECISION ON PROTEST

Pursuant to 2 GAR, Div. 4 § 9101(g), the Port of Guam ("Port") hereby issues its decision on the matters raised in a letter labeled "Bid Protest" ("Protest") hand delivered by Morrico Equipment ("Morrico") to the Port on June 3, 2024. Morrico filed its Protest after receiving written notice that Federal Contracts Corporation ("FCC") was determined to be the winning vendor for IFB-PAG-013-24, dated May 20, 2024. *Notice of Award for Invitation for Bid IFB-PAG-013-24 for 180' Telescopic Boom Lift (May 20, 2024)*. The Port hereby denies the Protest.

MORRICO PROTEST AND SUPPLEMENTAL PROTEST COMPLAINTS

1. The FCC is a non-responsive and/or non-responsible bidder because it did not submit "the bid security necessary for a responsive bid" and it "failed to execute and provide the Bid Bond form" therefore, the award issued to FCC "constituted a mistake...." *Morrigo Protest*, p. 1, Bid Protest, ¶ 2 (June 3, 2024); *Morrigo Supplemental Bid Protest*, p. 1, ¶ 2 (June 20, 2024).
2. The FCC is a non-responsive and/or non-responsible bidder because it "fails to have the necessary business and other licenses needed to make sales to the Port" and therefore, the award issued to FCC "constituted a mistake...." *Morrigo Protest*, p. 1, Bid Protest, ¶ 2 (June 3, 2024).
3. The FCC is a non-responsive and/or non-responsible bidder because its submitted bid form did not check the "Yes, offer as requested" check boxes on the bid form for several optional bid items listed on pp. 32-33 of the IFB solicitation document, and therefore, "an award cannot be made to FCC." *Morrigo Supplemental Bid Protest*, p. 2, Relief Requested (June 20, 2024).
4. Morrico's Supplemental Protest complains that "[o]n June 5, 2024, PAG declined to comply with the [June 3, 2024] Sunshine Act Request, and instead invited Morrico to proceed to PAG to review the records there. Our team eventually did review the records, and that review has necessitated this protest supplement." *Morrigo Supplemental Bid Protest*, p. 1, ¶ 1 (June 20, 2024).

Decision on Protest

Date: July 31, 2024

Subject: Decision on Protest of June 3, 2024, and "Supplement to Protest" of June 20, 2024, submitted by Morrico Equipment for Invitation for Bids IFB-PAG-013-24, re: Procurement of 180' Telescopic Boom Lift.

Page 2 of 21

MORRICO PROTEST REQUESTED REMEDIES

1. With respect to Morrico's first complaint, Morrico requests that FCC's winning submission be rejected, and the award to FCC rescinded, so that Morrico "should be made the awardee of the IFB." *Morrigo Protest*, p. 1, Relief Requested (June 3, 2024); *Morrigo Supplemental Bid Protest*, p. 2, Relief Requested (June 20, 2024).
2. With respect to Morrico's second complaint, Morrico requests that FCC's winning submission be rejected, and the award to FCC rescinded, so that Morrico "should be made the awardee of the IFB." *Morrigo Protest*, p. 1, Relief Requested (June 3, 2024).
3. With respect to Morrico's third complaint, Morrico requests that FCC's winning submission be rejected, and the award to FCC rescinded, so that Morrico "should be made the awardee of the IFB." *Morrigo Supplemental Bid Protest*, p. 2, Relief Requested (June 20, 2024).
4. With respect to Morrico's fourth complaint, Morrico makes no request for relief. Morrico requests no remedy under Guam's Procurement Law, Guam's Procurement Rules and Regulations, or the Sunshine Reform Act. *See* 5 GCA §§ 5451, 5452; 2 GAR, Div. 4 §§ 9104, 9105, and 9106; and 5 GCA §§ 10111, and 10112.

STATEMENT OF FINDINGS:

The Port makes the following findings:

I. Substantive Content of First, Second, and Third Protest and Supplemental Protest Complaints:

Morrigo complains that FCC was not required to submit a bid bond and a completed bid bond form as security to the government of Guam and/or the Port to secure its bid for this procurement, which resulted in a "*de facto* unfair pricing advantage" *Morrigo Supplemental Bid Protest*, p. 2, Relief Requested (June 20, 2024). Morrico further complains that FCC did not present Guam business licenses in its priced submission, rendering FCC non-responsive and/or non-responsible. Finally, on these bases, Morrico requests rejection of FCC's price quote, rescission of the May 20, 2024 Notice of Award, and award of a contract to itself. *Id.*

In order to constitute a valid protest, the protest must raise complaints regarding the "method of source selection, solicitation or award of a contract," 5 GCA § 5425(a). These objections in the Protest and Supplemental Protest do not raise complaints about the method of source selection used (*i.e.*, use of the Invitation for Bids process), nor do they raise complaints about the solicitation document that was issued or any of its terms or conditions. Morrico makes no complaint concerning the language or content of the IFB or any other part of the solicitation process. The

Decision on Protest

Date: July 31, 2024

Subject: Decision on Protest of June 3, 2024, and "Supplement to Protest" of June 20, 2024, submitted by Morrico Equipment for Invitation for Bids IFB-PAG-013-24, re: Procurement of 180' Telescopic Boom Lift.

Page 3 of 21

Protest documents unambiguously state that Morrico is aggrieved by the written announcement of FCC as the lowest responsible, responsive vendor in response to IFB-PAG-013-24 ("IFB"), after notice of an award of a contract to FCC, which Morrico received on May 20, 2024. *Morrigo Protest*, p. 1, Section II; see 5 GCA Section 5211(g) ("Award. The contract shall be awarded with reasonable promptness by written notice...."); and *Notice of Award* (May 20, 2024). The factual bases of these complaints solely raise allegations of defects in FCC's bid submission and the selection of FCC for award. Therefore, it is clear that Morrico protests the Port's the award of the contract to FCC, and no other part of the procurement process for this IFB.

II. *Unfounded Claims of a "Stay" of Procurement:*

Morrigo attempts to "stay" the procurement process in this matter by stating "[w]e understand this to be a pre-award procurement protest of IFB-PAG-013-24," in order to trigger the provisions of 5 GCA § 5425 and 2 GAR, Div. 4, § 9101(g), and thereby halt the procurement. *Morrigo Protest*, p. 1, Automatic Stay. Neither this statute nor this rule require a stay in this case. 2 GAR, Div. 4 § 9101(e) states: "[w]hen a protest has been filed within 14 days and before an award has been made, ... the head of a Purchasing Agency shall make no award of the contract prior to final resolution of such protest" *Id.* (emphases added). Likewise, 5 GCA § 5425(g) prevents the government from proceeding "with the award of the contract prior to final resolution of such protest" *Id.* (emphases added).

In order to stop the contract awarding process, a protestor must file its protest prior to the award. 2020 Guam 20, ¶ 148 (citing *Teleguam Holdings, LLC v. Guam*, 2015 Guam 13 ¶ 35 [hereinafter "*Teleguam Holdings P*"] and *Guam Imaging Consultants, Inc. v. Guam Mem'l Hosp. Auth.*, 2004 Guam 15 ¶ 24). A contract was already awarded in this matter on May 20, 2024, well before Morrico lodged its protest on June 3, 2024.

Without citation to fact or law, Morrico's Protest and Supplemental Protest attempt to characterize its protest as "pre-award," despite having received the clearly labeled "Notice of Award" for Invitation for Bid IFB-PAG-013-24. *Morrigo Protest*, p. 1, Automatic Stay. Morrico's claim is unfounded in fact or law. "How a protest is framed by the aggrieved bidder—including whether they frame the protest as a challenge to the solicitation, the evaluation, or the award—does not dictate when the time period to file a protest begins to run." *DFS v. GIAA*, 2020 Guam 20 ¶ 86 (footnote omitted).

The "Notice of Award" in this matter consists of the written notice issued to FCC as the winning vendor after the Port "evaluated the bids received" *Notice of Award*, IFB-PAG-013-24 (issued to Morrico and FCC). The Notice of Award sent to both Morrico and FCC clearly and unambiguously states that "the Port Authority of Guam is hereby announcing its award to the following bidder: Federal Contracts Corp." *Notice of Award*, IFB-PAG-013-24 (emphasis added).

Decision on Protest

Date: July 31, 2024

Subject: Decision on Protest of June 3, 2024, and "Supplement to Protest" of June 20, 2024, submitted by Morrico Equipment for Invitation for Bids IFB-PAG-013-24, re: Procurement of 180' Telescopic Boom Lift.

Page 4 of 21

This May 20, 2024 notice announcing the award was issued to both FCC and Morrico after evaluations were completed and FCC was found to be the lowest responsible and responsive vendor, in order to make the award to FCC known to all bidders and the public. 2 GAR, Div. 4 § 3109(q): "Publicizing Awards. Written notice of award shall be sent to the successful bidder. In procurement over \$25,000, each unsuccessful bidder shall be notified of the award. Notice of award shall be made available to the public." *Id*; see also 5 GCA § 5211(g) ((Competitive Sealed Bidding, Award) "Award. *The contract shall be awarded with reasonable promptness by written notice to the lowest responsible bidder....*") (emphases added). The contract was awarded, documented, and made known to everyone, including the successful vendor (FCC) and the unsuccessful vendor (Morrico), through this Notice of Award issued on May 20, 2024. Morrico waited until after this notice was issued and the bid status was provided to file its Protest. *Morrigo Protest*, p. 1, Section II.

Award in this matter was already made prior to the filing of the protest. Morrico's protest documents were all filed after award. Accordingly, the provisions of 5 GCA § 5425 and 2 GAR, Div. 4 § 9101(e) allowing a protestor to prevent an agency from making "*award of the contract prior to final resolution of such protest*" could not be triggered, and Morrico's Protest and Supplemental Protest have never operated to stay any portion of this procurement.

III. Unfounded Claims of "Declined" Sunshine Reform Act Request:

On June 3, 2024, Morrico filed its Protest, which included a records request labeled as a "Sunshine Act" request. In this request, Morrico stated: "Morrico requests ... that the Port provide to the company the complete procurement record kept for the IFB, as well as any record associated with IFB-PAG-004024(sic) and the decision to cancel that original bid process." *Morrigo Protest*, p. 2, Sunshine Act Request (June 3, 2024).

Morrigo's request does not specify any format or means of conveyance (electronic or otherwise) for any requested records. It simply says "provide to the company" any records. *Id*.

On June 5, 2024, the Port responded in writing to Morrico that the procurement record is always publicly available for inspection at all times during working hours, and that Guam's Procurement Law requires public access to the record at the earliest possible time and does not require a formal written request; therefore, the record was already available for Morrico to review.

The Protest and Supplemental Protest documents filed by Morrico fail to allege any injury or violation and fail to request any cognizable remedy under Guam's Procurement Law or Guam's Procurement Rules and Regulations. Morrico does not allege that any person or party has violated the Sunshine Reform Act or any other relevant law, and requests no particular available relief.

Morrigo attempts to portray the Port as non-responsive, even though the Port actually responded in writing within two (2) days of Morrico's Sunshine Reform Act request, and informed Morrico that the procurement record was available to Morrico at any time during working hours. The Port

Decision on Protest

Date: July 31, 2024

Subject: Decision on Protest of June 3, 2024, and "Supplement to Protest" of June 20, 2024, submitted by Morrico Equipment for Invitation for Bids IFB-PAG-013-24, re: Procurement of 180' Telescopic Boom Lift.

Page 5 of 21

further informed Morrico that no formal, written record request was even needed to review the Procurement Record, because it is public at all times pursuant to Guam's Procurement Law and Rules. Under these rules, a party may appear at an agency and request review of a procurement record without first filing a written request for records, unlike the Sunshine Reform Act.

There is no factual support for Morrico's unfounded allegation that the Port "declined to comply" with any request to produce records under any law. The Procurement Record has been available to Morrico at all times during this procurement, even prior to award and prior to its request. Morrico could have reviewed this record at any time, and did so, after the Port provided its response. *Morrigo Supplemental Bid Protest*, p. 1, ¶ 1 (June 20, 2024).

CONCLUSIONS:

The Port hereby denies the Protest. The bases for denial are set forth under each of Morrico's complaints as organized below:

I. **FCC's Bid Submission is Not Disqualified for Lack of Guam Bid Bond and Bid Bond Form:**

Untimely: The complaints in Morrico's Protest were untimely submitted. "Protests filed after the 14 day period shall not be considered." 2 GAR § 9109(b)(1). All of the bid submissions were opened publicly on May 8, 2024, including FCC's priced submission, containing its pricing, forms, and all alleged defective terms to which Morrico objects. All of these portions of FCC's submission have been available to Morrico and the public since May 8, 2024. Guam's Procurement Rules clearly state that:

Bids and modifications shall be opened publicly in the presence of one or more witnesses, at the time, date, and place designated in the Invitation for Bids. The name of each bidder, the bid price, and such other information as is deemed appropriate by the Procurement Officer, shall be read aloud or otherwise made available..... The opened bids shall be available for public inspection

2 GAR, Div. 4 § 3109(1)(2).

FCC's bid submission was publicly opened, its price quote was announced, and the full contents of its offer, including all documents submitted, were available to Morrico on May 8, 2024.

Therefore, May 8, 2024 is the date that Morrico was on notice that FCC's submission included all of the allegedly defective terms of which Morrico complains in the Protest(s). These documents and terms have not changed, and did not change upon the issuance of a Notice of Award. All of Morrico's claims are based on allegations that FCC's submission was "non-responsive" and that FCC is "non-responsible" based on items and documents that are alleged to be missing from FCC's

Decision on Protest

Date: July 31, 2024

Subject: Decision on Protest of June 3, 2024, and "Supplement to Protest" of June 20, 2024, submitted by Morrico Equipment for Invitation for Bids IFB-PAG-013-24, re: Procurement of 180' Telescopic Boom Lift.

Page 6 of 21

bid submission. All of the facts concerning FCC's bid upon which Morrico bases its Protest and Supplemental Protest were public and actually known to Morrico as of May 8, 2024. Yet, Morrico did not complain of these facts until after the Notice of Award was issued on May 20, 2024, announcing FCC as the "lowest, responsible, and responsive bid offer" with whom a finalized contract would be entered. *Morrigo Protest*, p. 1, Section II.

Morrigo waited to file its Protest (and its request for records) until June 3, 2024, after a winning vendor was announced by written notice to all vendors who submitted a bid. *Notice of Award*, IFB-PAG-013-24. It further waited another 17 days to file its Supplemental Bid Protest on June 20, 2024. Both the Protest and the Supplemental Protest contain only allegations that FCC's bid should be rejected as non-responsive and non-responsible due to the contents of its submission. There are no allegations concerning the IFB solicitation document or other aspects of the procurement process. The Protest(s) were submitted well beyond the 14-day time period of when Morrico first knew or should have known of the facts giving rise to its complaints. 5 GCA § 5425(a) and 2 GAR, Div. 4 § 9101(c)(1); *DFS Guam, L.P. v. The A.B. Won Pat International Airport Authority, Guam*, 2020 Guam 20, ¶ 95-96; *see also In the Appeal of ASC Trust Corporation*, OPA-PA-09-010 (finding that the fourteen-day clock begins when a party should first be aware of facts giving rise to the protest). Accordingly, Morrigo's complaints in its Protest and Supplemental Protest are untimely.

Morrigo is not entitled to any relief because its Protest(s) are not timely. It is not entitled to have any of its complaints considered on the merits. However, in order to establish a full record for posterity, the Port will further address the substance of Morrigo's arguments.

This Complaint Has No Merit: Morrigo complains that FCC is a non-responsive and/or non-responsible bidder because it did not submit "the bid security necessary for a responsive bid" and it "failed to execute and provide the Bid Bond form" *Morrigo Protest*, p. 1, ¶2; *Morrigo Supplemental Protest*, p. 1, ¶ 2.

However, Morrigo simply ignores the fact that, with respect to competitive solicitations by recipients using federal funds, federal law applies. 2 CFR § 200.101. More importantly, federal law controls. Whenever the government of Guam is conducting a procurement using federal funds, if Guam's Procurement Law and federal procurement laws or requirements conflict, federal law overrides Guam law. 5 GCA § 5501 ("Federal Funds. Where a procurement involves the expenditure of federal assistance or contract funds, or other federal funds ... all persons within the government of Guam shall comply with such federal law and regulations which are applicable and which may be in conflict with or may not be reflected in this Chapter.") and 5004(b) ("Nothing in this Chapter or in regulations promulgated hereunder shall prevent any governmental body ... from complying with the terms and conditions of any grant....").

Decision on Protest

Date: July 31, 2024

Subject: Decision on Protest of June 3, 2024, and "Supplement to Protest" of June 20, 2024, submitted by Morrico Equipment for Invitation for Bids IFB-PAG-013-24, re: Procurement of 180' Telescopic Boom Lift.

Page 7 of 21

Federal Law Controls this Procurement

This procurement is funded with federal funds from the U.S. Maritime Administration (MARAD) FY2022 American Marine Highway (AMH) Grant No.: 693JF72340007.

FCC is a contractor who has been awarded a contract by the Federal General Services Agency (Fed GSA), under GSA Contract #GS-03F-113DA, as a competitively selected vendor whose contract is publicly listed on the Multiple Award Schedule (MAS), also known as the Federal Supply Schedule, to provide supplies to qualifying governments and non-federal entities (NFE's), pursuant to federal law.

The MAS is a long-term government-wide contract with commercial firms providing eligible buyers access to commercial products and services at volume discount pricing. FAR §§ 8.401(a) and 38.101(a). Eligible NFE's that include state, tribal, and local governments, as well as some educational institutions, are permitted by law to procure goods and services from the Federal Supply Schedule/MAS. The government of Guam and its agencies (including the Port) are specifically authorized by federal law to use the Federal Supply Schedule/MAS. 48 U.S.C. § 1469e and 40 U.S.C. § 502(c)(2). "The Governments of the Commonwealth of Puerto Rico, Guam, American Samoa, the Commonwealth of the Northern Mariana Islands, and the United States Virgin Islands are authorized to make purchases through the General Services Administration." 48 U.S.C. 1469e (Pub. L. 102-247, title III, §302, Feb. 24, 1992, 106 Stat. 38; Pub. L. 114-187, title IV, §406, June 30, 2016, 130 Stat. 592).

Under these laws, Fed GSA offers multiple efficient and effective procurement programs for state, tribal, and local governments to purchase products and services directly from the pre-vetted and competitively selected contractors listed in the Federal Supply Schedule, at a bulk discount. FAR §§ 8.402(c)(2), 38.101(e); GSAR §§ 538.270, .271, and .273.

These contractors: 1) have already been certified as responsible by Fed GSA; 2) have already entered into a Fixed Price with Economic Price Adjustment (EPA) Indefinite Delivery Indefinite Quantity (IDIQ) contract resulting from a competitive open solicitation; and 3) are already bound by the contractual terms of the MAS. *Ids*, FAR §§ 8.401(a), 8.404(d), and 52.216-1; GSA Contract #GS-03F-113DA; and Multiple Award Schedule Solicitation Document Solicitation Number: 47QSMD20R0001.

Because these contractors have already competed in an open competitive solicitation and were selected for award of an MAS contract:

Orders placed against a Multiple Award Schedule (MAS), using the procedures in this subpart, are considered to be issued using full and open competition (see 6.102(d)(3)). (i) Ordering offices need not seek further competition, synopses the requirement, make a separate determination of fair and reasonable pricing, or

Decision on Protest

Date: July 31, 2024

Subject: Decision on Protest of June 3, 2024, and "Supplement to Protest" of June 20, 2024, submitted by Morrico Equipment for Invitation for Bids IFB-PAG-013-24, re: Procurement of 180' Telescopic Boom Lift.

Page 8 of 21

consider small business programs. (ii) GSA has already determined the prices of items under schedule contracts to be fair and reasonable.

FAR § 8.404(a)(1)(emphases added).

By law, eligible NFE's satisfy the federal requirements for full and open competition when they purchase from a Fed GSA schedule, and the Fed GSA ordering procedures are followed. Federal Acquisition Regulations (FAR) § 6.100 ("This subpart prescribes the policy and procedures that are to be used to promote and provide for full and open competition."); and FAR § 6.102 ("Use of competitive procedures. The competitive procedures available for use in fulfilling the requirement for full and open competition are as follows: ... (d)(3) Use of multiple award schedules issued under the procedures established by the Administrator of General Services consistent with the requirement of 41 U.S.C.152(3)(A) for the multiple award schedule program of the General Services Administration is a competitive procedure.") (emphasis added).

Pursuant to 2 CFR 200, states are NFE's when making procured purchases using federal funds. 2 CFR § 200.1, *Non-Federal Entity (NFE)*. If a state, which includes state and territorial agencies and instrumentalities, and includes the government of Guam and its agencies (*i.e.*, the Port), 2 CFR § 200.1 *state*, procures goods or services using the Federal Supply Schedule/MAS, the state must take steps to comply with its own procurement policies and rules, pursuant to 2 CFR § 200.317 through 2 CFR § 200.327, to the extent that those procurement rules and procedures do not conflict with federal mandates applicable to the funding source, 2 CFR 200, and any other applicable federal purchasing procedures. 2 CFR § 200.320 ("The non-Federal entity must have and use documented procurement procedures, consistent with the standards of this section and §§ 200.317, 200.318, and 200.319 ..."). NFE's may not change the terms and conditions of any MAS contract, except to add any required clauses that do not contravene the original terms. GSAR §§ 552.238-114(e), 538.7003(d); and 552.104(a).

Thus, when federal funds are involved, NFE's follow both the contract requirements of the MAS at GSAR Part 552 and the contracting requirements at 2 CFR Part 200 and Appendix II, plus §§ 200.317 – 200.327, to include the socioeconomic affirmative steps, contractor oversight, cost and price analysis, never contracting with the enemy, and all other required contract provisions located in 2 CFR Part 200.

Both Guam law and federal law require that Guam's local procurement processes must not conflict with federal requirements. 5 GCA §§ 5004(b) and 5501; 2 CFR §§ 200.318-320; and GSAR §§ 552.238-114(e), 538.7003(d). Thus, when procuring with federal funds, the government of Guam and the Port apply Guam's Procurement Law and Regulations and procurement processes to the extent that those processes do not conflict with any of the other federal requirements imposed on the procurement by operation of 2 CFR 200, the MAS contract, and the federal funding source.

Decision on Protest

Date: July 31, 2024

Subject: Decision on Protest of June 3, 2024, and "Supplement to Protest" of June 20, 2024, submitted by Morrico Equipment for Invitation for Bids IFB-PAG-013-24, re: Procurement of 180' Telescopic Boom Lift.

Page 9 of 21

Federal Law Prohibits Local Procurement Preferences and Both Guam and Federal Law Require Solicitation of Non-Local Vendors

2 CFR § 200.319(a) states: "[a]ll procurement transactions for the acquisition of property or services required under a Federal award must be conducted in a manner providing full and open competition consistent with the standards of this section and § 200.320." *Id.*

2 CFR § 200.319(c) requires: "[t]he non-Federal entity must conduct procurements in a manner that *prohibits the use of statutorily or administratively imposed state, local, or tribal geographical preferences* in the evaluation of bids or proposals" *Id.* (emphasis added).

Under federal law, NFE's are permitted to solicit from "pre-qualified lists" of vendors, but must "include enough qualified sources to ensure maximum open and free competition. Also, the non-Federal entity *must not preclude potential bidders from qualifying* during the solicitation period." 2 CFR § 200.319(e) (emphasis added).

In order to comply with both of these requirements, the IFB contains the provision:

5. NO LOCAL PROCUREMENT PREFERENCE: There is no geographical preference for this IFB in compliance with 2 CFR § 200.319(c) and the terms and conditions of MARAD FY2022 American Marine Highway (AMH) Grant No.: 693JF72340007; however, no specification, term, condition, or qualification of this IFB shall exclude any Offeror from consideration on the basis of Guam-only experience, provided that the experience of such Offeror is otherwise responsive to the solicitation, in accordance with the requirements of 5 GCA § 5008.

IFB, General Terms and Conditions, p.22, ¶5.

When federal funds are involved, the government of Guam cannot artificially exclude any vendors from bidding based solely on the geographical location of the business. It cannot solicit bids or proposals only from locally-based vendors and it cannot unduly restrict competition. If there are vendors anywhere who are known to be interested in a solicitation, the government of Guam must allow the competition to be open to all such vendors. *Id.*

The MAS is a published, publicly available, government-compiled list of vendors who are interested in providing specific supplies and services to qualified government entities, including the government of Guam. FAR §§ 8.401(a) and 38.101(a).

GSA schedule contracts require all schedule contractors to publish an 'Authorized Federal Supply Schedule Pricelist' (pricelist). The pricelist contains all supplies and services offered by a schedule contractor. In addition, each pricelist contains the

Decision on Protest

Date: July 31, 2024

Subject: Decision on Protest of June 3, 2024, and "Supplement to Protest" of June 20, 2024, submitted by Morrico Equipment for Invitation for Bids IFB-PAG-013-24, re: Procurement of 180' Telescopic Boom Lift.

Page 10 of 21

pricing and the terms and conditions pertaining to each Special Item Number that is on schedule.

FAR § 8.402(b).

FCC is on this list, specifically offering the goods solicited in IFB-PAG-013-24 under GSA Contract #GS-03F-113DA, which is open until Jun 12, 2026. Therefore, the Port was required to include FCC in this open competition.

Guam's Procurement Law contains provisions consistent with the requirement to solicit from all vendors, no matter their business location. "Publication of bids and requests for proposals shall not be manipulated so as to place potential bidders at unnecessary competitive disadvantage." 5 GCA § 5010.

2 GAR, Div. 4, § 3109(f)(1): "Distribution. Invitations for Bids or Notices of the Availability of Invitation for Bids shall be mailed or otherwise furnished to a sufficient number of bidders for the purpose of securing competition."

The purposes of Guam's Procurement Law include stated policies:

(4) to ensure the fair and equitable treatment of all persons who deal with the procurement system of Guam; (5) to provide increased economy in Guam activities and to maximize to the fullest extent practicable the purchasing value of public funds of Guam; (6) to foster effective broad-based competition within the free enterprise system; ...

5 GCA § 5001(b)(4), (5), and (6).

The "free enterprise system" refers to an economy where the market determines the prices of goods and services rather than the government. *See* 22 USC § 2351, Encouragement of free enterprise and private participation ("The Congress of the United States recognizes the vital role of free enterprise in achieving rising levels of production and standards of living essential to economic progress and development."). In order to maximize the purchasing value of the federal grant money that is funding this procurement under the free enterprise system, the solicitation must allow priced submissions from the full market of available vendors.

In accordance with these mandates, the IFB also contained specific notice that the pricing of contractors listed on the Federal Supply Schedules would be accepted in response to this solicitation:

48. FEDERAL GSA SCHEDULES: This IFB is federally funded under MARAD FY2022 American Marine Highway (AMH) Grant No.: 693JF72340007; The Port Authority of Guam is accepting Federal GSA pricing inclusive with shipping cost

Decision on Protest

Date: July 31, 2024

Subject: Decision on Protest of June 3, 2024, and "Supplement to Protest" of June 20, 2024, submitted by Morrico Equipment for Invitation for Bids IFB-PAG-013-24, re: Procurement of 180' Telescopic Boom Lift.

Page 11 of 21

to Guam. If the bid pricing existing on the Federal GSA website from a qualified vendor for qualifying items on the date of the opening of the bids, plus the confirmed price of shipping costs to Guam, confirmed after the opening of the bids, is the lowest price, then the contract will be awarded to that vendor.

IFB, General Terms and Conditions, p.25, ¶48.

FCC is Already an Awarded Contractor

The heart of Morrico's argument is the allegation that FCC "was provided with a *de facto* unfair pricing advantage that other offerors could not avail themselves of" because FCC "provided no bid security" *Morrigo Protest*, p. 1, Bid Protest, ¶ 2 (June 3, 2024);

Morrigo appears to have complaints about differential treatment. However, FCC has a different legal contracting status than Morrico. "Contractor means any person having a contract with a governmental body," 5 GCA § 5030, *contractor*; and 2 GAR, Div. 4, § 1106(6). FCC is an already awarded contractor. Morrico is not. Accordingly, certain laws and terms don't apply to FCC, and certain laws and terms don't apply to Morrico.

FCC is an established, awarded MAS contractor with "established catalogue pricing." 5 GCA § 5030; 2 GAR, Div. 4, § 1106(6) and (24); and FAR § 8.402(b).

MAS Contractors are already legally and contractually obligated to fill all accepted orders from authorized buyers that fall between the minimum and maximum order limits specified in each MAS contract, at the catalog price, pursuant to Federal Acquisition Regulations § 552.238-114, Use of Federal Supply Schedule Contracts by Eligible Non-Federal Entities (NFE's).

By law, NFE's may not impose any new terms and conditions that conflict with the primary MAS contract. FAR § 552.238-114(e). Once it is determined that the purchasing entity has imposed no such conflicting requirements, a new task order is issued incorporating any new terms and conditions, and a supplemental contract incorporating all of the terms and conditions of the MAS primary contract is generated. FAR § 552.238-114(d)(1) and (2). Thus, the MAS contract automatically continues in effect for any governmental entities placing orders under the existing primary MAS contract. *Id.*

MAS contractors have already been determined to be responsive and responsible to the nationwide continuous open solicitation. FAR §§ 8.401(a), 38.101(e), and 52.216-1; GSAR §§ 538.270, .271, and .273; and <https://www.highergov.com/idv/GS03F113DA/>. Because FCC has already been required to compete in the open market for its MAS contract, FCC is not simply a bidder, but a pre-vetted, responsible and responsive contractor whose pricing has already been pre-determined to be fair and reasonable. *Id.*

Decision on Protest

Date: July 31, 2024

Subject: Decision on Protest of June 3, 2024, and "Supplement to Protest" of June 20, 2024, submitted by Morrico Equipment for Invitation for Bids IFB-PAG-013-24, re: Procurement of 180' Telescopic Boom Lift.

Page 12 of 21

Federal Law Prohibits Imposition of a Bid Bond on FCC by the Government of Guam

For MAS contractors, who have already entered into a contract with Fed GSA to supply goods and services, FAR § 28.103-1(c) applies, and expressly prohibits the government of Guam from imposing a bid bond for goods and services on these contractors. It states: "[n]o bond shall be required after the contract has been awarded if it was not specifically required in the contract, except as may be determined necessary for a contract modification." *Id.*

By law, the government of Guam cannot impose any additional bid bonding requirements on FCC outside of the MAS contract, because it is already an awarded contractor. *Id.*; see also FAR §§ 28.103-1(a) and 28.101-1; GSA Contract #GS-03F-113DA; and Multiple Award Schedule Solicitation Document Solicitation Number: 47QSMD20R0001.

Because this procurement was funded by federal funds, to the extent that any of the Guam IFB solicitation provisions conflict with federal law, as applied, the federal law controls. This includes any provision of the IFB solicitation document that purports to require FCC to submit a bid bond to the government of Guam.

Federal Law Does Not Prohibit Imposition of a Bid Bond on Morrico by the Government of Guam

Under Guam law, bid bonds are not automatically required for purchases of supplies. They are required when the Procurement Officer makes a finding that a bid bond is necessary to "enforce forfeiture of such bond or deposit if the successful bidder fails to enter into contract within the prescribed time." 2 GAR, Div. 4 §§ 3109(c)(3)(emphasis added), and 3102(f); see also 5 GCA 5212(c).

The purpose of bid bonding and security is to protect the interests of the government by deterring bidders from withdrawing their bids or failing to deliver promised goods or services, because they will otherwise forfeit the bid security to the purchasing entity. This gives the purchasing entity some assurance that the selected bidder will sign the contract and deliver the contracted items or otherwise forfeit their bid bond/security.

FCC already has legal bid security for this IFB in the form of its MAS contract. FCC is already contractually guaranteed to perform and deliver the procured supplies under the contract, and no additional bid bond or bid security can be required from FCC. FAR §§ 28.103-1(a) and (c), 28.101-1; and GSA Contract #GS-03F-113DA.

In contrast, Morrico is not an awarded contractor. It is only a bidder. FAR § 28.001. Morrico does not have an existing, competitively selected IDIQ contract with any governmental entity to supply the items solicited in IFB-PAG-13-024. Morrico has not competed in the open market, and has not been pre-determined to be responsive and responsible. There is no guarantee in place that Morrico will perform the requirements of this IFB. FAR § 28.103-1(c) does not apply to Morrico.

Decision on Protest

Date: July 31, 2024

Subject: Decision on Protest of June 3, 2024, and "Supplement to Protest" of June 20, 2024, submitted by Morrico Equipment for Invitation for Bids IFB-PAG-013-24, re: Procurement of 180' Telescopic Boom Lift.

Page 13 of 21

Therefore, Morrico is required to submit a bid bond as bid security as requested in the IFB because Morrico is under no other contractual or legal obligation to provide the government of Guam with the goods or supplies offered in its bid.

II. FCC is Not Disqualified Based on Licensing:

Untimely: For the same reasons stated in the previous section of the Conclusions, this argument concerning defects in FCC's bid submission is untimely and is entitled to no consideration.

In order to protest, Morrico must be "aggrieved" by the alleged violations of law, and its grievance must be within the Port's authority to remedy under Guam's Procurement Law. 5 GCA § 5425(a).

Morrigo Fails to Request Appropriate Relief: Failure to ask for the appropriate remedy provided by law, failure to specifically set forth the causes of action, or any failure to strictly follow the mandates of the laws or rules conferring jurisdiction upon an adjudicative body deprives the adjudicative body of jurisdiction to hear the matter, and mandates dismissal of the action. *California v. Texas*, 141 S.Ct. 2104, 2115-2116, 210 L.Ed.2d 230 (June 17, 2021) (Plaintiffs were deprived of standing by failing to request the appropriate relief available under the law); and *see e.g., Iwachiw v. New York State Bd. of Elections*, 186 Misc.2d 577, 719 N.Y.S.2d 800 (N.Y.Sup., 2000)(dismissal appropriate where petition failed to state a cause of action based on vague, conclusory allegations, and failed to request the specific relief provided by statute).

Although not clearly stated, Morrico appears to allege that FCC is possibly violating some unidentified business or other licensing laws. It is unclear whether Morrico alleges that FCC is possibly violating Guam laws or the laws of another jurisdiction. Morrico does not set forth what specific "business or other licenses" it believes FCC is required to have.

The Port does not determine what licenses FCC or any other business is required to have or obtain to perform or conduct any business in any jurisdiction. In Guam, the License Board makes such determinations. 11 GCA § 70122.

The Guam Department of Revenue and Taxation ("DRT") is the public body authorized to make determinations of required licensure and to enforce Guam's Business License Law. *See* 11 GCA §§ 70103(j), 70104, and 70122. It is uncertain what "other" licensing laws Morrico is referencing in its Protest; however, if Morrico believes that FCC is in violation of any Guam business licensing requirements, it is required to seek the remedies and enforcement provided for violations of the Guam Business License Law and/or any other appropriate licensing laws from DRT. 11 GCA §§ 70129 and 70131. If Morrico has legitimate claims that FCC, as a business, is violating the provisions of Guam's Business License Law or any other license requirement, Morrico has an adequate remedy available at law, and must file its complaints and pursue its claims of violation with DRT and the License Board, which is the proper entity to determine whether FCC is required to have or maintain any licenses in Guam. 11 GCA §§ 70103(j), 70104, 70122, 70129, and 70131.

Decision on Protest

Date: July 31, 2024

Subject: Decision on Protest of June 3, 2024, and "Supplement to Protest" of June 20, 2024, submitted by Morrico Equipment for Invitation for Bids IFB-PAG-013-24, re: Procurement of 180' Telescopic Boom Lift.

Page 14 of 21

Morrigo is Not Aggrieved: Morrigo is not aggrieved pursuant to 5 GCA § 5425(a) or 2 GAR, Div. 4 § 9101(a)(1)(a). A protestor must be "legally aggrieved" to have standing. *Teleguam Holdings LLC v. Guam and Pacific Data Systems, Inc.*, 2018 Guam 5 ¶ 14 (internal citation omitted). In order to demonstrate that a protestor is "legally aggrieved" and thereby has standing to pursue a protest, the protestor must adequately establish: (1) an injury in fact (i.e., a "concrete and particularized" invasion of a "legally protected interest"); (2) causation (i.e., a "fairly ... trace[able]" connection between the alleged injury in fact and the alleged conduct of the defending party); and (3) redressability (i.e., it is "likely" and not "merely 'speculative'" that the plaintiff's injury will be remedied by the relief plaintiff seeks in bringing suit). *Lujan v. Defenders of Wildlife*, 504 U.S. 555, 560-561 (1992); and *Linsangan v. Gov't of Guam*, 2020 Guam 27 ¶ 15.

This complaint is vague and ambiguous. Morrigo does not clearly set forth any concrete wrongdoing, and does not state any particular law or laws of any jurisdiction which FCC is supposed to be violating, if any. If FCC is, in fact, failing to obtain appropriate licenses from any required jurisdiction, then FCC may be subject to penalties for such violations in that appropriate jurisdiction. However, such violations are committed against the governing bodies of those jurisdictions, the violations are not committed against Morrigo. Morrigo fails to demonstrate how the alleged failure of a competing business to obtain any unspecified licenses deprived Morrigo of its ability to participate in this procurement, or deprived Morrigo of any other rights that Morrigo may have to conduct its own business.

This Complaint Has No Merit: Morrigo claims that FCC's alleged failure "to have necessary business and other licenses needed to make sales to the Port" renders FCC non-responsible and non-responsive to this solicitation, *Morrigo Protest*, p. 1, Bid Protest, ¶ 2. However, the IFB did not require vendors to submit any proof of any licensure with their bid submissions. Therefore, this complaint concerns only FCC's responsibility, not its responsiveness to the IFB.

As already discussed, as an awardee of an MAS contract, FCC has already been determined to be responsible, FAR §§ 8.402(c)(2), 8.401(a), 8.404(d), 9.103(a), 38.101(e), and 52.216-1; GSAR §§ 538.270, .271, and .273; and GSA Contract #GS-03F-113DA, and FCC is specifically authorized to enter into contracts with the government of Guam for supplies and services. 48 U.S.C. § 1469e and 40 U.S.C. § 502(c)(2); and GSAR § 552.238-114.

This determination of responsibility required review and approval of "the performance and integrity information available in the Federal Awardee Performance and Integrity Information System (FAPIIS), (available at <https://www.cpars.gov>), including FAPIIS information from the System for Award Management (SAM) Exclusions and the Contractor Performance Assessment Reporting System (CPARS)." FAR § 9.104-6(a)(1).

The determination of responsibility does not mandate review of any licensing requirements under federal law or Guam law. FAR § 9.104-1; 2 GAR, Div. 4 § 3116(b)(2).

Decision on Protest

Date: July 31, 2024

Subject: Decision on Protest of June 3, 2024, and "Supplement to Protest" of June 20, 2024, submitted by Morrico Equipment for Invitation for Bids IFB-PAG-013-24, re: Procurement of 180' Telescopic Boom Lift.

Page 15 of 21

Guam law requires only that "[b]efore awarding a contract, the Procurement Officer must be satisfied that the prospective contractor is responsible." 2 GAR, Div. 4 § 3116(b)(2). Bidders or contractors are not required to provide proof of responsibility unless requested. 2 GAR, Div. 4 § 3116(b)(2)(B) and (b)(3).

Guam's Procurement Law does not require a contractor to have any particular licensing and does not govern such concerns. The IFB provides that bidders must "comply with Guam's Licensing Law. Specific information on licenses may be obtained from the Director of Revenue and Taxation." IFB, General Terms and Conditions, p.22, ¶ 4. The solicitation does not require FCC or any bidders to provide any proof or copies of any specific licensure with any bid submissions. FCC's submission did not fail to comply with the requirements of the IFB.

A solicitation provision mandating that the contractor comply with all necessary licenses or permits needed to perform the work does not require that a bidder or offeror provide proof or documentation of compliance prior to award. *Mid-America Mgmt. Servs., Inc.*, B-244103, June 5, 1991, 91-1 CPD ¶ 537 at 1-2. The securing of licenses and permits is a performance requirement that may be satisfied during contract performance and does not affect the award decision. *HAP Constr., Inc.*, B-278515, Feb. 9, 1998, 98-1 CPD ¶ 48 at 2-3.

As applied to a requirement for licensing, if a solicitation does not obligate a bidder to provide a particular license before award, it is not a definitive responsibility criterion; rather, it is a contract performance requirement that does not affect a decision to award a contract. *Restec Contractors, Inc.*, B-245862, Feb. 6, 1992, 92-1 CPD ¶ 154 at 4; *see also Evergreen Int'l Airlines, Inc.*, B-244284, Aug. 15, 1991, 91-2 CPD ¶ 154 at 3*.

There are multiple ways to comply with business licensing laws in Guam without obtaining a Guam Business License, including the exemption granted pursuant to 11 GCA § 70126(a) for business that is conducted "for the sole and direct benefit of or under the direct supervision of the Government of Guam." *Id.* Furthermore, certain businesses are not required to obtain a Guam Business License for certain acts, including: "(6) soliciting or procuring orders, whether by mail or through employees or agents or otherwise, where those orders require acceptance outside Guam before they become binding contracts; ... and (11) transacting business in interstate commerce." 11 GCA § 70103(e)(6) and (11). FCC is transacting business in interstate commerce. FCC's sale of a boom lift to the Port is for the sole and direct benefit of the Port. FCC's MAS offerings are not available commercially in Guam, and can only be sold to federal entities and the government of Guam by orders placed through the Federal Supply Schedule. 48 U.S.C. 1469e; FAR Part 38; and GSAR § 552.238-114. Although the Port does not here make any formal determinations regarding licensure, it appears that FCC is not required to have a Guam Business License, and is complying with licensing laws.

The Port is satisfied that FCC is a responsible contractor.

Decision on Protest

Date: July 31, 2024

Subject: Decision on Protest of June 3, 2024, and "Supplement to Protest" of June 20, 2024, submitted by Morrico Equipment for Invitation for Bids IFB-PAG-013-24, re: Procurement of 180' Telescopic Boom Lift.

Page 16 of 21

III. FCC's Bid is Not Disqualified Based on Failure to Select Bid Options

Untimely: For the same reasons stated in the previous sections of the Conclusions, this argument concerning defects in FCC's bid submission is untimely and is entitled to no consideration.

This Complaint Has No Merit: The Port now addresses the remainder of Morrico's allegations. Morrico claims that:

- a) "FCC failed to execute and provide the required "Special Reminder to Prospective Bidders";
- b) FCC is "non-responsive in refusing to provide training as described and required on page 32 of the IFB";
- c) "FCC refused to offer and provide the warranty required by the IFB";
- d) "FCC refused to offer and provide technical assistance as sought on page 33 of the IFB;
- e) "FCC refused to offer and provide service as required on page 33 of the IFB;
- f) "FCC does not have a local authorized dealer as required on page 33 of the IFB; and
- g) "FCC refused to provide complete familiarization training as required on page 33 of the IFB."

Although Morrico claims that these items affect both FCC's responsibility and responsiveness, these factors do not implicate FCC's fitness to perform the contract; they only involve FCC's responsiveness to the IFB.

1) *Execution of the Special Reminder to Prospective Bidders Form is Not Required*

Morrigo makes multiple allegations that simply are not accurate. First among these, Morrigo claims that execution of the Special Reminder to Prospective Bidders form is "required," and therefore FCC's bid submission should be rejected as non-responsive. This is incorrect. Failure to execute the reminder form "may be cause for disqualification and rejection of the bid." *IFB, Special Reminder to Prospective Bidders*, p. 1. "Shall is mandatory and may is permissive." 1 GCA § 715(h)(9). The IFB does not require rejection of FCC's bid for failure to execute or provide the Special Reminder form.

2) *All Bid Items are Not Required To be Bid*

Morrigo further claims that multiple alternate bidding items included in the IFB are mandatory, and not optional. These terms include training, warranty, technical assistance, service, and requiring the manufacturer to have a local dealer.

Morrigo confuses "specifications" with bid items. "Specification means any description of the physical or functional characteristics, or of the nature of a supply, service, or construction item. 5 GCA § 5260(emphases added); *see also* 2 GAR, Div. 4 § 4101(4). A bid item is a specific, distinct unit of supply, service, or construction for which individual specifications are created (also sometimes referred to as "line items"). *Id.*; § 4103(b)(1)(b) and (d); and FAR § 4.1003; "The purpose of a specification is to serve as a basis for obtaining a supply, service, or construction item ..." 2 GAR, Div. 4 § 4102(a)(1) (emphases added).

Decision on Protest

Date: July 31, 2024

Subject: Decision on Protest of June 3, 2024, and "Supplement to Protest" of June 20, 2024, submitted by Morrico Equipment for Invitation for Bids IFB-PAG-013-24, re: Procurement of 180' Telescopic Boom Lift.

Page 17 of 21

Morrico apparently argues that training, warranty, technical assistance, service, and requiring the manufacturer to have a local dealer are all part of the characteristics of a boom lift. This is not accurate. These are separate bid items, as each constitutes a separate service that is not part of the physical or functional characteristics, or nature of the boom lift specifications. FAR § 4.1003(a)(1) and (2) "(1) A supply is separately identifiable if it has its own identification (*e.g.*, national stock number (NSN), item description, manufacturer's part number). (2) Services are separately identifiable if they have no more than one statement of work or performance work statement."). The boom lift is a supply item with its own purchase description, manufacturer's number, and an established fixed delivery date; but the training, warranty, technical assistance, and other service items each have their own separate delivery requirements, period(s) of performance, locations of performance, and no associated manufacturer's numbers, since they are not supply items. FAR § 4.1003(d).

Multiple and/or alternate bid items may be included in an IFB. 2 GAR, Div. 4 § 3102(d). Likewise, a solicitation may or may not require a bidder to bid on all bid items. "All or None Bids or Proposals. Only when provided by the solicitation may a bid or proposal limit acceptance to the entire bid or proposal offering. Otherwise, such bids or proposals shall be deemed to be nonresponsive." 2 GAR, Div. 4 § 3115(f).

The Port specifically did not require the bidders to bid all bid items, and did not include a limitation of the Port's acceptance of the bids to all bid items or none. The IFB shows that check box #7 in the General Terms and Conditions is not checked. It explicitly states: "'ALL OR NONE' BIDS: NOTE: By checking this item, the Government is requesting all of the bid items to be bided (*sic*) or none at all." *IFB*, General Terms and Conditions, p. 22, ¶ 7. The Port did not require all bid items to be bid for this IFB. The Port is not limited to acceptance of an entire bid and all bid items or nothing.

In this IFB, the Port is specifically authorized to "award, cancel, or reject bids in whole or in part for any one or more items" if it is in the best interests of the government. *IFB*, General Terms and Conditions, p. 23, ¶ 22; and 2 GAR, Div. 4 § 3115(e)(2). The Government reserves the right to increase or decrease the quantity of the items for award and make additional awards for the same type items and the vendor agrees to such modifications and additional awards ... after original award." *IFB*, General Terms and Conditions, p. 23, ¶ 22.

The Port may award on any part of the bid submissions and reject the remainder of any bid items it does not need. 2 GAR, Div. 4 §§ 3115(f). The Port may further make additional awards of the separate bid items after the original award of the accepted bid items. *Ids.* Individual awards may be made for the items or combinations of bid items that result in the best interests of serving the needs of the Port. The Port was not required to award on all of the different and optional bid items.

Decision on Protest

Date: July 31, 2024

Subject: Decision on Protest of June 3, 2024, and "Supplement to Protest" of June 20, 2024, submitted by Morrico Equipment for Invitation for Bids IFB-PAG-013-24, re: Procurement of 180' Telescopic Boom Lift.

Page 18 of 21

The Port awarded a contract for the purchase of the boom lift, and was not required to award a contract for all of the listed bid items, including training, warranty, technical assistance, service, and requiring the manufacturer to have a local dealer¹.

IV. The Port Complied with Morrico's Records Request

Morrigo submitted a "Sunshine Reform Act" request on June 3, 2024, and the Port responded to this request in writing on June 5, 2024. The Port then produced the entire procurement record for Morrico. Morrico's claims of any non-compliance with any law are factually and legally inaccurate. Morrico has not set forth any violation of any law, nor has it requested any relief for any alleged failure to comply with any records request. 2 GAR, Div. 4 §§ 9104, 9105, 9106; and 5 GCA §§ 5451 and 5452.

Untimely: The facts concerning the Sunshine Reform Act request upon which Morrico bases this complaint were known to Morrico as of June 5, 2024, which is the date that Morrico states that the Port "declined to comply with the Sunshine Act request" *Morrigo Supplemental Protest*, p. 1, ¶ 1. In order to file a protest on this factual basis, Morrico would have been required to submit a protest concerning these facts on or before June 19, 2024. This particular complaint was first raised in the Supplemental Protest filed on June 20, 2024, and is untimely.

Morrigo is Not Aggrieved: Guam adopted its procurement statutes and regulations in 1983 from the 1979 Model Procurement Code promulgated by the American Bar Association. Accordingly, case law from other states interpreting similarly adopted versions of the ABA Model Procurement Code constitutes persuasive case law in Guam. *Gibbs v. Holmes*, 2001 Guam 11, ¶ 15.

The state of Indiana adopted a similar version of the ABA Model Procurement Code in 1981. In *City of Fort Wayne v. Pierce Mfg., Inc.*, 853 N.E.2d 508 (Ind. Ct. App. 2006), the Indiana Court of Appeals conducted an in-depth analysis of the meaning of the term "person aggrieved," and concluded that an unsuccessful bidder did not have standing to maintain suit for alleged violations of procurement rules that did not affect the bidder's ability to participate in the procurement process; therefore, it could not show that it suffered any injury to its pecuniary, property, or personal interests for such immaterial breaches of procedure. *Id.* at 517.

Even if taken as true, at best, Morrico's statement describes non-compliance with a records request that occurred *after* it discovered that award of IFB-PAG-013-24 was made to another bidder. Morrico has not been prevented from participating in the procurement process by any alleged non-compliance with its records request, and is not "aggrieved." A "conjectural or hypothetical" injury to "the process" will not satisfy the requirements necessary to establish standing. *Lujan v. Defenders of Wildlife*, 504 U.S. 555, 560-61 (1992). No facts alleged in this fourth complaint

¹ Requiring a third-party manufacturer, such as JLG, who is not a vendor or bidder, and is not a participant in the procurement, to maintain a local authorized dealer is not a valid or enforceable bid item.

Decision on Protest

Date: July 31, 2024

Subject: Decision on Protest of June 3, 2024, and "Supplement to Protest" of June 20, 2024, submitted by Morrico Equipment for Invitation for Bids IFB-PAG-013-24, re: Procurement of 180' Telescopic Boom Lift.

Page 19 of 21

regarding Morrico's Sunshine Reform Act request operated to penalize Morrico or prevent Morrico from participating in this solicitation or the IFB process. Morrico is not suffering, nor will suffer any injury to any personal, property, or pecuniary rights stemming from its records request. Whether the Port appropriately responded to the Sunshine Reform Act request is irrelevant to Morrico's participation in this IFB. Even if a court were to find in favor of Morrico on this claim, there is no detriment to Morrico. Morrico has entirely failed to assert "entitlement" to any relief under Guam's Procurement Law, or any other law.

Morrigo has suffered no injury, and is not aggrieved by any possible alleged violation of the Sunshine Reform Act or other laws governing records requests.

Morrigo Requests No Relief: In this fourth enumerated complaint, Morrico does not ask for any relief under any statute or rule. Morrico has not specifically alleged any violation of any law, and has failed to request any redress or remedy available for a procurement protest or otherwise. 2 GAR, Div. 4 §§ 9104, 9105, 9106; and 5 GCA §§ 5451 and 5452. Morrico merely characterizes the Port's timely response making the record available to Morrico as "declin[ing] to comply." *Morrigo Supplemental Protest*, p. 1, ¶ 1. Morrico entirely fails to request an available legal remedy for any possible suggested violation, stating only that "[o]ur team eventually did review the records, and that review has necessitated this protest supplement." *Morrigo Supplemental Protest*, p. 1, ¶ 1. Even if this "complaint" in the Protest were to be sustained, there is no request for an available remedy that can be granted, and therefore, no "injury ... that is likely to be redressed by a favorable decision." *Simon v. E. Kentucky Welfare Rights Org.*, 426 U.S. 26, 38 (1976).

This Complaint Alleges no Violation of Law: In order to sustain a protest, it must be determined that the solicitation or award "is in violation of law." 2 GAR, Div. § 9104(a)(1); and 5 GCA § 5450. Morrico's fourth enumerated complaint fails to allege any violations of the laws or rules governing procurements. Further, Morrico makes no claim that the Sunshine Reform Act was violated. Regarding this fourth complaint, Morrico makes no explicit claim that any law was violated. There is no remedy available where there has been no violation of law.

Even if Morrico were to allege specific violations of Guam's Sunshine Reform Act (which it has not), Morrico would be required to seek the remedies provided for violations of the Sunshine Reform Act (which it has not). *See* 5 GCA § 10108; and *M.S. v. Brown*, 902 F.3d 1076, 1082, 1083-1090 (9th Cir. 2018) (Even where a plaintiff requests relief that could redress a claimed injury, there is no redressability, as required for standing, if the requested relief is beyond the scope of available relief).

Morrigo fails to indicate any procurement provision or other law which has been violated, and fails to show any prejudice stemming from any such violation. Therefore, it must be denied.

This Complaint Has No Merit: The Port has no duty to deliver or send Morrico copies of any records under any law.

Decision on Protest

Date: July 31, 2024

Subject: Decision on Protest of June 3, 2024, and "Supplement to Protest" of June 20, 2024, submitted by Morrico Equipment for Invitation for Bids IFB-PAG-013-24, re: Procurement of 180' Telescopic Boom Lift.

Page 20 of 21

5 GCA § 5251 states: "Public Record. The record required by § 5249 of this Chapter is a public record and, subject to rules promulgated by the Public Auditor, any person may inspect and copy any portion of the record." *Id.* (emphases added).

Under Guam's Procurement Law, a party has a right to access the procurement records current to the present stage of the procurement, which are public and not confidential, to inspect them and make copies of any portions of these records. 5 GCA § 5252. A party does not have the right to demand transmission of any records in an unspecified format to an unspecified location, especially without providing payment of any associated costs.

The Sunshine Reform Act (SRA) is also clear in this matter. 5 GCA § 10103 is entitled "Right of Inspection of Public Documents." 5 GCA § 10103 (emphasis added). It states:

(a) Every person has the right to inspect and take a copy of any public document on Guam, except as otherwise expressly prohibited in law, and except as provided in § 10108 of this Chapter. (b) Public records are open to inspection at all times during the office hours of the agency and every person has a right to inspect any public record, . . ."

5 GCA § 10103(a)(emphases added).

Pursuant to the SRA, a party has a right to go to the office of any public agency to inspect and then explicitly identify the records of which it would like copies, in any reasonable form. The party must clearly identify the documents sought. A party does not have the right to make public employees guess at which records a party would like to take copies of, or deliver unspecified copies to an unidentified location (online or otherwise), without having the party inspect and clearly identify specific documents, and then pay any fees for reproduction of those documents in a specified available format. 5 GCA §§ 10103(c) (agencies "shall make the records promptly available to any person, upon payment of fees covering direct costs of duplication, or a statutory fee, if applicable."); and 10104(b). 5 GCA § 10201 reiterates that a party only has a right to inspection prior to taking any copies in any specified form:

Inspection of Public Records; Certified Copies. Every person has a right to inspect any public writing on record in Guam and every public officer having the custody thereof is bound to permit such inspection, and to give on demand and on payment of the legal fees therefor a certified copy of such writing or record.

5 GCA § 10201 (emphases added).

Morrigo did not identify particular documents for copying or transmission, and never requested production of any records in any specified manner or format, electronic or not. Morrigo's request did not even supply an email, physical address, or other means of transmission for any subject records, stating only "provide to the company the complete procurement record" *Morrigo*

Decision on Protest

Date: July 31, 2024

Subject: Decision on Protest of June 3, 2024, and "Supplement to Protest" of June 20, 2024, submitted by Morrico Equipment for Invitation for Bids IFB-PAG-013-24, re: Procurement of 180' Telescopic Boom Lift.

Page 21 of 21

Protest, p. 2, Sunshine Act Request. Despite this vague missive, the Port immediately responded to Morrico's request, and produced the entire procurement records for IFB-PAG-013-24 and IFB-PAG-004-24, so that Morrico could inspect these records and then identify and take copies of any documents it needed, in any readily available format. There is no legal or factual merit to Morrico's allegation that the Port "declined to comply with the Sunshine Act request," *Morrigo Supplemental Protest*, p. 1, ¶ 1, and this protest complaint is denied on this basis as well.

SUMMARY OF CONCLUSIONS:

Morrigo's Protest is untimely, as it was filed more than 14 days after Morrico knew or should have known of the complaints it has lodged regarding FCC's bid submission, which was public on May 8, 2024. Morrico's complaints in the Protest and Supplemental Protest are not entitled to any consideration. Further, the contract was already awarded, documented, and made known to everyone, including the successful vendor (FCC) and the unsuccessful vendor (Morrigo) through the Notice of Award issued on May 20, 2024. Accordingly, the stay provisions were not triggered.

Morrigo's additional complaint of any "declined" records request is also legally and factually unfounded. Finally, even if the Port were to consider Morrico's untimely protest(s), there is no merit to any of Morrico's complaints regarding the selection of FCC as the lowest, responsible, responsive vendor. Morrico is not aggrieved. Morrico was not harmed or prejudiced in any way, nor prevented from competing or having its bid duly considered in a full and open competitive selection procedure.

Pursuant to 5 GCA § 5425(c) this decision is final and conclusive. Protestor is advised that it has the right to administrative and judicial review.

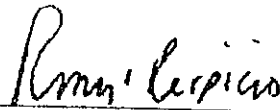

Rory J. Respicio, General Manager
Procurement Officer
Port Authority of Guam

8b



PORT OF GUAM

ATURIDAT I PUETTON GUAHAN

Jose D. Leon Guerrero Commercial Port

1026 Cabras Highway, Suite 201, Piti, Guam 96915

Telephone: 671-477-5931/35 Facsimile: 671-477-2689/4445

Website: www.portguam.com



Lourdes A. Leon Guerrero
Governor of Guam

Joshua F. Tenorio
Lieutenant Governor

Pete Pierson
Vice President
Federal Contracts Corp
Delivered via e-mail: pete@federalcontractscorp.com

Date: August 20, 2024

Re: Notification of Procurement Appeal for IFB-PAG-013-24 (Re-bid 180' Telescopic Boom Lift)

Hafa Adai Mr. Pierson,

This letter is to inform you that the Port of Guam (“Port”) has received a procurement appeal filed with the Office of Public Accountability for IFB-PAG-013-24.

The Port is required to provide this formal notification of the administrative procurement appeal, DOCKET NO. OPA-PA-24-002, to the awarded contractor for the procurement, pursuant to 2 GAR, Div. 4 § 12104(c)(2). Should you have any questions, or should you like to request any documents, please contact the Port’s Procurement Division, or you may obtain and review the public filings at <https://www.opaguam.org/procurement-appeals/search-procurement-appeals#14303>.

9

CERTIFICATION of COMPLETED PROCUREMENT RECORD

Instructions: After ascertaining the statement's accuracy and truthfulness, the agency's procurement officer (director or head of agency) must sign the Certification below to indicate that the agency has kept a complete procurement record of all documents required by law. The checklist below is provided to ensure that the record is complete, and must be filled out by the procurement officer or administrator. The checklist is comprised of every item that is required by law for an invitation for bid (IFB) or a request for proposal (RFP), and therefore every item, except as noted below, must be checked for the resulting contract to be considered legally sufficient. Please assemble the procurement record in the order stated below and place it in a three-ring binder, with visible tabs for each of the items below appearing in numerical order.

IFB/RFP No: IFB-PAG-013-24 Contractor: Federal Contracts Corp.

- 1. Published notice in newspaper of general circulation
- 2. Procurement package (IFB or RFP) issued to bidders or offerors
- 3. Log of distribution of procurement package
- N/A 4. Amendments to IFB or RFP, if any were issued
- N/A 5. Logs of distribution of amendments to IFB or RFP, but only if amendments were issued
- V/A 6. Minutes or summary of pre-submission conferences, but only if conferences were held
- V/A 7. Logs of attendees of pre-submission conferences, but only if conferences were held
- N/A 8. Written questions from bidders or offerors, but only if any questions were received
- N/A 9. Written answers, but only if any questions were received
- V/A 10. Proof that written answers were provided to all potential bidders or offerors, but only if any questions were received
- 11. Log of bids or registry of proposals received
- 12. Each bid or proposal received Attached to Procurement Record
- 13. Evaluation of proposals or analysis of bids (bids are not required by law to be analyzed, but may be)
- 14. Tabulation of evaluations or analysis (tabulations are not required by law but recommended)
- 15. Letters to bidders concerning outcome of bid; for offerors, letters informing them of ranking and letter to best qualified offeror inviting negotiations Notice of Award May 20
- N/A 16. Memorandum of evaluations and negotiations (only required for RFP's)
- 17. Notice of ~~intent~~ to award
- 18. Any and all communications from or to anyone concerning any part of IFB or RFP
- 19. Contract, including all draft versions
- 20. Bid protests, if any, and responses thereto Morrico's June 3rd protest
- 21. Any determination required by law as may fit the circumstances

CERTIFICATION: Pursuant to 5 G.C.A. §5250, I hereby certify under penalty of perjury that I am the procurement officer responsible for administering the solicitation of the acquisition referenced above, and that I have caused to be prepared and now maintain a full and complete record of the procurement as required by law.

Signature: [Signature]
Print Name: [Signature] Date: 6/6/24

10a

RE: Notice of Award for IFB-PAG-013-024 Re-bid 180' Telescopic Boom Lift

From : Pete Pierson <pete@federalcontractscorp.com>
Subject : RE: Notice of Award for IFB-PAG-013-024 Re-bid 180'
Telescopic Boom Lift
To : Mark A. Cabrera <macabrera@portofguam.com>

Wed, May 29, 2024 05:53 AM

📎 4 attachments

Hello Mark,

Attached is our W-9 and business license. Our EIN # is 42-1613127.

Please let me know if you need anything else.

Thank you,

Pete



Pete Pierson, Vice President
PH: 813.631.0000 FX: 813.631.0008
pete@federalcontractscorp.com

GSA & DLA Contract Holder
"Keeping Government Purchasing Simple"

Service Disabled Veteran Owned Small Business, *HUBZone Vendor*

From: Mark A. Cabrera <macabrera@portofguam.com>
Sent: Monday, May 27, 2024 9:25 PM
To: Pete Pierson <pete@federalcontractscorp.com>
Subject: Re: Notice of Award for IFB-PAG-013-024 Re-bid 180' Telescopic Boom Lift

Hello Mr. Peirson-

Can you provide me with a current copy of your business license and W-9 with EIN#? We need to register Pacific Federal Contracts Corporation as a Port vendor before I can process a purchase order or contract.

Thank You,

Mark A. Cabrera
Procurement Buyer Supervisor



Port Authority of Guam
1026 Cabras Highway
Suite 201 Piti GU 96915
(671)477-5931 ext. 252
macabrera@portofguam.com

From: "Mark A. Cabrera" <macabrera@portofguam.com>
To: "Pete Pierson" <pete@federalcontractscorp.com>
Sent: Tuesday, May 28, 2024 10:22:02 AM
Subject: Re: Notice of Award for IFB-PAG-013-024 Re-bid 180' Telescopic Boom Lift

Mr. Pierson,

Thank you for your quick response. We are preparing the purchase order. I will indicate 180 days delivery on it and will also include the contract cover which is the page from the solicitation that you had acknowledged. Needless to say, the Port is excited regarding this Procurement.

Respectfully,

Mark A. Cabrera
Procurement Buyer Supervisor



Port Authority of Guam
1026 Cabras Highway
Suite 201 Piti GU 96915
(671)477-5931 ext. 252
macabrera@portofguam.com

From: "Pete Pierson" <pete@federalcontractscorp.com>
To: "Mark A. Cabrera" <macabrera@portofguam.com>
Sent: Thursday, May 23, 2024 3:51:43 AM
Subject: RE: Notice of Award for IFB-PAG-013-024 Re-bid 180' Telescopic Boom Lift

Mark,

The lead time right now is 5 month ARO, plus transit time. I would say 30 days transit time to be safe. 180 days total to deliver.

Thank you,

Pete



Pete Pierson, Vice President
PH: 813.631.0000 FX: 813.631.0008
pete@federalcontractscorp.com

GSA & DLA Contract Holder
"Keeping Government Purchasing Simple"
Service Disabled Veteran Owned Small Business, HUBZone Vendor

From: Mark A. Cabrera <macabrera@portofguam.com>
Sent: Tuesday, May 21, 2024 10:09 PM
To: Pete Pierson <pete@federalcontractscorp.com>
Subject: Re: Notice of Award for IFB-PAG-013-024 Re-bid 180' Telescopic Boom Lift

Mr. Pierson-

Just wanted to confirm with you if Federal Contracts Corp can deliver within 150 days as noted in your bid submittal? The documents to award are being prepared and should be issued to you very soon.

Respectfully,

Mark A. Cabrera
Procurement Buyer Supervisor



Port Authority of Guam
1026 Cabras Highway
Suite 201 Piti GU 96915
(671)477-5931 ext. 252

macabrera@portofguam.com

From: "Pete Pierson" <pete@federalcontractscorp.com>
To: "Mark A. Cabrera" <macabrera@portofguam.com>
Cc: "Annie Sablan" <algsablan@portofguam.com>
Sent: Tuesday, May 21, 2024 10:09:17 PM
Subject: RE: Notice of Award for IFB-PAG-013-024 Re-bid 180' Telescopic Boom Lift

Hello,

We greatly appreciate your consideration and acknowledge your request.

Thank you,

Pete



Pete Pierson, Vice President
PH: 813.631.0000 FX: 813.631.0008
pete@federalcontractscorp.com

GSA & DLA Contract Holder
"Keeping Government Purchasing Simple"
Service Disabled Veteran Owned Small Business, HUBZone Vendor

From: Mark A. Cabrera <macabrera@portofguam.com>
Sent: Tuesday, May 21, 2024 2:01 AM
To: Pete Pierson <pete@federalcontractscorp.com>
Cc: algsablan <algsablan@portofguam.com>
Subject: Notice of Award for IFB-PAG-013-024 Re-bid 180' Telescopic Boom Lift

Hafa Adai Mr. Pierson-

Congratulations! Kindly acknowledge the attached request so that we may move forward with the Procurement process.

Thank You,

Mark A. Cabrera

Procurement Buyer Supervisor



Port Authority of Guam
1026 Cabras Highway
Suite 201 Piti GU 96915
(671)477-5931 ext. 252
macabrera@portofguam.com

 **w9-fcc.pdf**
146 KB

 **Certificate of Good Standing 2024.pdf**
116 KB

Re: Notice of Award for IFB-PAG-013-024 Re-bid 180' Telescopic Boom Lift

From : Mark A. Cabrera <macabrera@portofguam.com> Wed, May 29, 2024 09:41 AM
Subject : Re: Notice of Award for IFB-PAG-013-024 Re-bid 180' Telescopic Boom Lift 5 attachments
To : Pete Pierson <pete@federalcontractscorp.com>
Cc : MaryJane Garcia <mjgarcia@portofguam.com>

Good Morning Mr. Pierson,

Thank you for the quick response. I will provide to our Finance Department so that a vendor number is assigned and we can proceed with the contract and purchase order.

For now, this is all we need. Will get back to you soon.

Best Regards,

Mark A. Cabrera
Procurement Buyer Supervisor



Port Authority of Guam
1026 Cabras Highway
Suite 201 Piti GU 96915
(671)477-5931 ext. 252
macabrera@portofguam.com

From: "Pete Pierson" <pete@federalcontractscorp.com>
To: "Mark A. Cabrera" <macabrera@portofguam.com>
Sent: Wednesday, May 29, 2024 5:53:39 AM
Subject: RE: Notice of Award for IFB-PAG-013-024 Re-bid 180' Telescopic Boom Lift

Hello Mark,

Attached is our W-9 and business license. Our EIN # is 42-1613127.

Please let me know if you need anything else.

Thank you,

Pete



Pete Pierson, Vice President

PH: 813.631.0000 FX: 813.631.0008

pete@federalcontractscorp.com

GSA & DLA Contract Holder

"Keeping Government Purchasing Simple"

Service Disabled Veteran Owned Small Business, *HUBZone Vendor*

From: Mark A. Cabrera <macabrera@portofguam.com>

Sent: Monday, May 27, 2024 9:25 PM

To: Pete Pierson <pete@federalcontractscorp.com>

Subject: Re: Notice of Award for IFB-PAG-013-024 Re-bid 180' Telescopic Boom Lift

Hello Mr. Peirson-

Can you provide me with a current copy of your business license and W-9 with EIN#? We need to register Pacific Federal Contracts Corporation as a Port vendor before I can process a purchase order or contract.

Thank You,

Mark A. Cabrera
Procurement Buyer Supervisor



Port Authority of Guam
1026 Cabras Highway
Suite 201 Piti GU 96915
(671)477-5931 ext. 252
macabrera@portofguam.com

From: "Mark A. Cabrera" <macabrera@portofguam.com>
To: "Pete Pierson" <pete@federalcontractscorp.com>
Sent: Tuesday, May 28, 2024 10:22:02 AM
Subject: Re: Notice of Award for IFB-PAG-013-024 Re-bid 180' Telescopic Boom Lift

Mr. Pierson,

Thank you for your quick response. We are preparing the purchase order. I will indicate 180 days delivery on it and will also include the contract cover which is the page from the solicitation that you had acknowledged. Needless to say, the Port is excited regarding this Procurement.

Respectfully,

Mark A. Cabrera
Procurement Buyer Supervisor



Port Authority of Guam
1026 Cabras Highway
Suite 201 Piti GU 96915
(671)477-5931 ext. 252
macabrera@portofguam.com

From: "Pete Pierson" <pete@federalcontractscorp.com>
To: "Mark A. Cabrera" <macabrera@portofguam.com>
Sent: Thursday, May 23, 2024 3:51:43 AM
Subject: RE: Notice of Award for IFB-PAG-013-024 Re-bid 180' Telescopic Boom Lift

Mark,

The lead time right now is 5 month ARO, plus transit time. I would say 30 days transit time to be safe. 180 days total to deliver.

Thank you,

Pete



Pete Pierson, Vice President

PH: 813.631.0000 FX: 813.631.0008

pete@federalcontractscorp.com

GSA & DLA Contract Holder

"Keeping Government Purchasing Simple"

Service Disabled Veteran Owned Small Business, *HUBZone Vendor*

From: Mark A. Cabrera <macabrera@portofguam.com>

Sent: Tuesday, May 21, 2024 10:09 PM

To: Pete Pierson <pete@federalcontractscorp.com>

Subject: Re: Notice of Award for IFB-PAG-013-024 Re-bid 180' Telescopic Boom Lift

Mr. Pierson-

Just wanted to confirm with you if Federal Contracts Corp can deliver within 150 days as noted in your bid submittal? The documents to award are being prepared and should be issued to you very soon.

Respectfully,

Mark A. Cabrera
Procurement Buyer Supervisor



Port Authority of Guam
1026 Cabras Highway
Suite 201 Piti GU 96915
(671)477-5931 ext. 252
macabrera@portofguam.com

From: "Pete Pierson" <pete@federalcontractscorp.com>
To: "Mark A. Cabrera" <macabrera@portofguam.com>
Cc: "Annie Sablan" <algsablan@portofguam.com>
Sent: Tuesday, May 21, 2024 10:09:17 PM
Subject: RE: Notice of Award for IFB-PAG-013-024 Re-bid 180' Telescopic Boom Lift

Hello,

We greatly appreciate your consideration and acknowledge your request.

Thank you,

Pete



Pete Pierson, Vice President

PH: 813.631.0000 FX: 813.631.0008

pete@federalcontractscorp.com

GSA & DLA Contract Holder

"Keeping Government Purchasing Simple"

Service Disabled Veteran Owned Small Business, *HUBZone Vendor*

From: Mark A. Cabrera <macabrera@portofguam.com>
Sent: Tuesday, May 21, 2024 2:01 AM
To: Pete Pierson <pete@federalcontractscorp.com>
Cc: algsablan <algsablan@portofguam.com>
Subject: Notice of Award for IFB-PAG-013-024 Re-bid 180' Telescopic Boom Lift

Hafa Adai Mr. Pierson-

Congratulations! Kindly acknowledge the attached request so that we may move forward with the Procurement process.

Thank You,

Mark A. Cabrera
Procurement Buyer Supervisor



Port Authority of Guam
1026 Cabras Highway
Suite 201 Piti GU 96915
(671)477-5931 ext. 252
macabrera@portofguam.com



logo.jpeg
14 KB

 **w9-fcc.pdf**
146 KB

 **Certificate of Good Standing 2024.pdf**
116 KB

State of Florida

Department of State

I certify from the records of this office that FEDERAL CONTRACTS CORP is a corporation organized under the laws of the State of Florida, filed on December 5, 2003.

The document number of this corporation is P03000148343.

I further certify that said corporation has paid all fees due this office through December 31, 2024, that its most recent annual report/uniform business report was filed on January 12, 2024, and that its status is active.

I further certify that said corporation has not filed Articles of Dissolution.

*Given under my hand and the
Great Seal of the State of Florida
at Tallahassee, the Capital, this
the Twelfth day of January, 2024*



Secretary of State

Tracking Number: 7129621573CC

To authenticate this certificate, visit the following site, enter this number, and then follow the instructions displayed.

<https://services.sunbiz.org/Filings/CertificateOfStatus/CertificateAuthentication>

Request for Taxpayer Identification Number and Certification

**Give Form to the
requester. Do not
send to the IRS.**

Print or type See Specific Instructions on page 2.	1 Name (as shown on your income tax return). Name is required on this line; do not leave this line blank. Federal Contracts Corp	
	2 Business name/disregarded entity name, if different from above	
	3 Check appropriate box for federal tax classification; check only one of the following seven boxes: <input type="checkbox"/> Individual/sole proprietor or single-member LLC <input type="checkbox"/> C Corporation <input checked="" type="checkbox"/> S Corporation <input type="checkbox"/> Partnership <input type="checkbox"/> Trust/estate <input type="checkbox"/> Limited liability company. Enter the tax classification (C=C corporation, S=S corporation, P=partnership) ▶ _____ Note. For a single-member LLC that is disregarded, do not check LLC; check the appropriate box in the line above for the tax classification of the single-member owner. <input type="checkbox"/> Other (see instructions) ▶ _____	
	4 Exemptions (codes apply only to certain entities, not individuals; see instructions on page 3): Exempt payee code (if any) _____ Exemption from FATCA reporting code (if any) _____ <i>(Applies to accounts maintained outside the U.S.)</i>	
	5 Address (number, street, and apt. or suite no.) 12918 N. Nebraska Ave	Requester's name and address (optional)
	6 City, state, and ZIP code Tampa, FL 33612	
	7 List account number(s) here (optional)	

Part I Taxpayer Identification Number (TIN)																																																																
Enter your TIN in the appropriate box. The TIN provided must match the name given on line 1 to avoid backup withholding. For individuals, this is generally your social security number (SSN). However, for a resident alien, sole proprietor, or disregarded entity, see the Part I instructions on page 3. For other entities, it is your employer identification number (EIN). If you do not have a number, see <i>How to get a TIN</i> on page 3.																																																																
Note. If the account is in more than one name, see the instructions for line 1 and the chart on page 4 for guidelines on whose number to enter.																																																																
	<table border="1" style="margin: auto;"> <tr><td colspan="9" style="text-align: center;">Social security number</td></tr> <tr><td style="width: 20px; height: 20px;"></td><td style="width: 20px; height: 20px;"></td><td style="width: 20px; height: 20px;"></td><td style="width: 20px; height: 20px;"></td><td style="width: 20px; height: 20px;"></td><td style="width: 20px; height: 20px;"></td><td style="width: 20px; height: 20px;"></td><td style="width: 20px; height: 20px;"></td><td style="width: 20px; height: 20px;"></td></tr> <tr><td colspan="3" style="text-align: center;">-</td><td colspan="3" style="text-align: center;">-</td><td colspan="3"></td></tr> <tr><td colspan="9" style="text-align: center;">or</td></tr> <tr><td colspan="9" style="text-align: center;">Employer identification number</td></tr> <tr><td style="width: 20px; height: 20px;">4</td><td style="width: 20px; height: 20px;">2</td><td style="width: 20px; height: 20px;"></td><td style="width: 20px; height: 20px;">-</td><td style="width: 20px; height: 20px;">1</td><td style="width: 20px; height: 20px;">6</td><td style="width: 20px; height: 20px;">1</td><td style="width: 20px; height: 20px;">3</td><td style="width: 20px; height: 20px;">1</td></tr> <tr><td style="width: 20px; height: 20px;"></td><td style="width: 20px; height: 20px;"></td><td style="width: 20px; height: 20px;"></td><td style="width: 20px; height: 20px;"></td><td style="width: 20px; height: 20px;"></td><td style="width: 20px; height: 20px;"></td><td style="width: 20px; height: 20px;"></td><td style="width: 20px; height: 20px;"></td><td style="width: 20px; height: 20px;">7</td></tr> </table>	Social security number																		-			-						or									Employer identification number									4	2		-	1	6	1	3	1									7
Social security number																																																																
-			-																																																													
or																																																																
Employer identification number																																																																
4	2		-	1	6	1	3	1																																																								
								7																																																								

Part II Certification	
Under penalties of perjury, I certify that:	
1. The number shown on this form is my correct taxpayer identification number (or I am waiting for a number to be issued to me); and	
2. I am not subject to backup withholding because: (a) I am exempt from backup withholding, or (b) I have not been notified by the Internal Revenue Service (IRS) that I am subject to backup withholding as a result of a failure to report all interest or dividends, or (c) the IRS has notified me that I am no longer subject to backup withholding; and	
3. I am a U.S. citizen or other U.S. person (defined below); and	
4. The FATCA code(s) entered on this form (if any) indicating that I am exempt from FATCA reporting is correct.	
Certification instructions. You must cross out item 2 above if you have been notified by the IRS that you are currently subject to backup withholding because you have failed to report all interest and dividends on your tax return. For real estate transactions, item 2 does not apply. For mortgage interest paid, acquisition or abandonment of secured property, cancellation of debt, contributions to an individual retirement arrangement (IRA), and generally, payments other than interest and dividends, you are not required to sign the certification, but you must provide your correct TIN. See the instructions on page 3.	

Sign Here	Signature of Pete Pierson	Date ▶ 05/28/2024
------------------	----------------------------------	-------------------

Digitally signed by Pete Pierson
DN: cn=Pete Pierson, o=Federal Contracts Corp. ou,
email=pete@federalcontractscorp.com, c=US
Date: 2024.02.21 11:59:32 -0500

General Instructions

Section references are to the Internal Revenue Code unless otherwise noted.

Future developments. Information about developments affecting Form W-9 (such as legislation enacted after we release it) is at www.irs.gov/fw9.

Purpose of Form

An individual or entity (Form W-9 requester) who is required to file an information return with the IRS must obtain your correct taxpayer identification number (TIN) which may be your social security number (SSN), individual taxpayer identification number (ITIN), adoption taxpayer identification number (ATIN), or employer identification number (EIN), to report on an information return the amount paid to you, or other amount reportable on an information return. Examples of information returns include, but are not limited to, the following:

- Form 1099-INT (interest earned or paid)
- Form 1099-DIV (dividends, including those from stocks or mutual funds)
- Form 1099-MISC (various types of income, prizes, awards, or gross proceeds)
- Form 1099-B (stock or mutual fund sales and certain other transactions by brokers)
- Form 1099-S (proceeds from real estate transactions)
- Form 1099-K (merchant card and third party network transactions)

- Form 1098 (home mortgage interest), 1098-E (student loan interest), 1098-T (tuition)
- Form 1099-C (canceled debt)
- Form 1099-A (acquisition or abandonment of secured property)

Use Form W-9 only if you are a U.S. person (including a resident alien), to provide your correct TIN.

If you do not return Form W-9 to the requester with a TIN, you might be subject to backup withholding. See What is backup withholding? on page 2.

By signing the filled-out form, you:

1. Certify that the TIN you are giving is correct (or you are waiting for a number to be issued),
2. Certify that you are not subject to backup withholding, or
3. Claim exemption from backup withholding if you are a U.S. exempt payee. If applicable, you are also certifying that as a U.S. person, your allocable share of any partnership income from a U.S. trade or business is not subject to the withholding tax on foreign partners' share of effectively connected income, and
4. Certify that FATCA code(s) entered on this form (if any) indicating that you are exempt from the FATCA reporting, is correct. See *What is FATCA reporting?* on page 2 for further information.

Note. If you are a U.S. person and a requester gives you a form other than Form W-9 to request your TIN, you must use the requester's form if it is substantially similar to this Form W-9.

Definition of a U.S. person. For federal tax purposes, you are considered a U.S. person if you are:

- An individual who is a U.S. citizen or U.S. resident alien;
- A partnership, corporation, company, or association created or organized in the United States or under the laws of the United States;
- An estate (other than a foreign estate); or
- A domestic trust (as defined in Regulations section 301.7701-7).

Special rules for partnerships. Partnerships that conduct a trade or business in the United States are generally required to pay a withholding tax under section 1446 on any foreign partners' share of effectively connected taxable income from such business. Further, in certain cases where a Form W-9 has not been received, the rules under section 1446 require a partnership to presume that a partner is a foreign person, and pay the section 1446 withholding tax. Therefore, if you are a U.S. person that is a partner in a partnership conducting a trade or business in the United States, provide Form W-9 to the partnership to establish your U.S. status and avoid section 1446 withholding on your share of partnership income.

In the cases below, the following person must give Form W-9 to the partnership for purposes of establishing its U.S. status and avoiding withholding on its allocable share of net income from the partnership conducting a trade or business in the United States:

- In the case of a disregarded entity with a U.S. owner, the U.S. owner of the disregarded entity and not the entity;
- In the case of a grantor trust with a U.S. grantor or other U.S. owner, generally, the U.S. grantor or other U.S. owner of the grantor trust and not the trust; and
- In the case of a U.S. trust (other than a grantor trust), the U.S. trust (other than a grantor trust) and not the beneficiaries of the trust.

Foreign person. If you are a foreign person or the U.S. branch of a foreign bank that has elected to be treated as a U.S. person, do not use Form W-9. Instead, use the appropriate Form W-8 or Form 8233 (see Publication 515, Withholding of Tax on Nonresident Aliens and Foreign Entities).

Nonresident alien who becomes a resident alien. Generally, only a nonresident alien individual may use the terms of a tax treaty to reduce or eliminate U.S. tax on certain types of income. However, most tax treaties contain a provision known as a "saving clause." Exceptions specified in the saving clause may permit an exemption from tax to continue for certain types of income even after the payee has otherwise become a U.S. resident alien for tax purposes.

If you are a U.S. resident alien who is relying on an exception contained in the saving clause of a tax treaty to claim an exemption from U.S. tax on certain types of income, you must attach a statement to Form W-9 that specifies the following five items:

1. The treaty country. Generally, this must be the same treaty under which you claimed exemption from tax as a nonresident alien.
2. The treaty article addressing the income.
3. The article number (or location) in the tax treaty that contains the saving clause and its exceptions.
4. The type and amount of income that qualifies for the exemption from tax.
5. Sufficient facts to justify the exemption from tax under the terms of the treaty article.

Example. Article 20 of the U.S.-China income tax treaty allows an exemption from tax for scholarship income received by a Chinese student temporarily present in the United States. Under U.S. law, this student will become a resident alien for tax purposes if his or her stay in the United States exceeds 5 calendar years. However, paragraph 2 of the first Protocol to the U.S.-China treaty (dated April 30, 1984) allows the provisions of Article 20 to continue to apply even after the Chinese student becomes a resident alien of the United States. A Chinese student who qualifies for this exception (under paragraph 2 of the first protocol) and is relying on this exception to claim an exemption from tax on his or her scholarship or fellowship income would attach to Form W-9 a statement that includes the information described above to support that exemption.

If you are a nonresident alien or a foreign entity, give the requester the appropriate completed Form W-8 or Form 8233.

Backup Withholding

What is backup withholding? Persons making certain payments to you must under certain conditions withhold and pay to the IRS 28% of such payments. This is called "backup withholding." Payments that may be subject to backup withholding include interest, tax-exempt interest, dividends, broker and barter exchange transactions, rents, royalties, nonemployee pay, payments made in settlement of payment card and third party network transactions, and certain payments from fishing boat operators. Real estate transactions are not subject to backup withholding.

You will not be subject to backup withholding on payments you receive if you give the requester your correct TIN, make the proper certifications, and report all your taxable interest and dividends on your tax return.

Payments you receive will be subject to backup withholding if:

1. You do not furnish your TIN to the requester,
2. You do not certify your TIN when required (see the Part II instructions on page 3 for details),

3. The IRS tells the requester that you furnished an incorrect TIN,
4. The IRS tells you that you are subject to backup withholding because you did not report all your interest and dividends on your tax return (for reportable interest and dividends only), or
5. You do not certify to the requester that you are not subject to backup withholding under 4 above (for reportable interest and dividend accounts opened after 1983 only).

Certain payees and payments are exempt from backup withholding. See *Exempt payee code* on page 3 and the separate Instructions for the Requester of Form W-9 for more information.

Also see *Special rules for partnerships* above.

What is FATCA reporting?

The Foreign Account Tax Compliance Act (FATCA) requires a participating foreign financial institution to report all United States account holders that are specified United States persons. Certain payees are exempt from FATCA reporting. See *Exemption from FATCA reporting code* on page 3 and the Instructions for the Requester of Form W-9 for more information.

Updating Your Information

You must provide updated information to any person to whom you claimed to be an exempt payee if you are no longer an exempt payee and anticipate receiving reportable payments in the future from this person. For example, you may need to provide updated information if you are a C corporation that elects to be an S corporation, or if you no longer are tax exempt. In addition, you must furnish a new Form W-9 if the name or TIN changes for the account; for example, if the grantor of a grantor trust dies.

Penalties

Failure to furnish TIN. If you fail to furnish your correct TIN to a requester, you are subject to a penalty of \$50 for each such failure unless your failure is due to reasonable cause and not to willful neglect.

Civil penalty for false information with respect to withholding. If you make a false statement with no reasonable basis that results in no backup withholding, you are subject to a \$500 penalty.

Criminal penalty for falsifying information. Willfully falsifying certifications or affirmations may subject you to criminal penalties including fines and/or imprisonment.

Misuse of TINs. If the requester discloses or uses TINs in violation of federal law, the requester may be subject to civil and criminal penalties.

Specific Instructions

Line 1

You must enter one of the following on this line; do not leave this line blank. The name should match the name on your tax return.

If this Form W-9 is for a joint account, list first, and then circle, the name of the person or entity whose number you entered in Part I of Form W-9.

a. **Individual.** Generally, enter the name shown on your tax return. If you have changed your last name without informing the Social Security Administration (SSA) of the name change, enter your first name, the last name as shown on your social security card, and your new last name.

Note. ITIN applicant: Enter your individual name as it was entered on your Form W-7 application, line 1a. This should also be the same as the name you entered on the Form 1040/1040A/1040EZ you filed with your application.

b. **Sole proprietor or single-member LLC.** Enter your individual name as shown on your 1040/1040A/1040EZ on line 1. You may enter your business, trade, or "doing business as" (DBA) name on line 2.

c. **Partnership, LLC that is not a single-member LLC, C Corporation, or S Corporation.** Enter the entity's name as shown on the entity's tax return on line 1 and any business, trade, or DBA name on line 2.

d. **Other entities.** Enter your name as shown on required U.S. federal tax documents on line 1. This name should match the name shown on the charter or other legal document creating the entity. You may enter any business, trade, or DBA name on line 2.

e. **Disregarded entity.** For U.S. federal tax purposes, an entity that is disregarded as an entity separate from its owner is treated as a "disregarded entity." See Regulations section 301.7701-2(c)(2)(ii). Enter the owner's name on line 1. The name of the entity entered on line 1 should never be a disregarded entity. The name on line 1 should be the name shown on the income tax return on which the income should be reported. For example, if a foreign LLC that is treated as a disregarded entity for U.S. federal tax purposes has a single owner that is a U.S. person, the U.S. owner's name is required to be provided on line 1. If the direct owner of the entity is also a disregarded entity, enter the first owner that is not disregarded for federal tax purposes. Enter the disregarded entity's name on line 2, "Business name/disregarded entity name." If the owner of the disregarded entity is a foreign person, the owner must complete an appropriate Form W-8 instead of a Form W-9. This is the case even if the foreign person has a U.S. TIN.

Line 2

If you have a business name, trade name, DBA name, or disregarded entity name, you may enter it on line 2.

Line 3

Check the appropriate box in line 3 for the U.S. federal tax classification of the person whose name is entered on line 1. Check only one box in line 3.

Limited Liability Company (LLC). If the name on line 1 is an LLC treated as a partnership for U.S. federal tax purposes, check the "Limited Liability Company" box and enter "P" in the space provided. If the LLC has filed Form 8832 or 2553 to be taxed as a corporation, check the "Limited Liability Company" box and in the space provided enter "C" for C corporation or "S" for S corporation. If it is a single-member LLC that is a disregarded entity, do not check the "Limited Liability Company" box; instead check the first box in line 3 "Individual/sole proprietor or single-member LLC."

Line 4, Exemptions

If you are exempt from backup withholding and/or FATCA reporting, enter in the appropriate space in line 4 any code(s) that may apply to you.

Exempt payee code.

- Generally, individuals (including sole proprietors) are not exempt from backup withholding.
- Except as provided below, corporations are exempt from backup withholding for certain payments, including interest and dividends.
- Corporations are not exempt from backup withholding for payments made in settlement of payment card or third party network transactions.
- Corporations are not exempt from backup withholding with respect to attorneys' fees or gross proceeds paid to attorneys, and corporations that provide medical or health care services are not exempt with respect to payments reportable on Form 1099-MISC.

The following codes identify payees that are exempt from backup withholding. Enter the appropriate code in the space in line 4.

- 1—An organization exempt from tax under section 501(a), any IRA, or a custodial account under section 403(b)(7) if the account satisfies the requirements of section 401(f)(2)
- 2—The United States or any of its agencies or instrumentalities
- 3—A state, the District of Columbia, a U.S. commonwealth or possession, or any of their political subdivisions or instrumentalities
- 4—A foreign government or any of its political subdivisions, agencies, or instrumentalities
- 5—A corporation
- 6—A dealer in securities or commodities required to register in the United States, the District of Columbia, or a U.S. commonwealth or possession
- 7—A futures commission merchant registered with the Commodity Futures Trading Commission
- 8—A real estate investment trust
- 9—An entity registered at all times during the tax year under the Investment Company Act of 1940
- 10—A common trust fund operated by a bank under section 584(a)
- 11—A financial institution
- 12—A middleman known in the investment community as a nominee or custodian
- 13—A trust exempt from tax under section 664 or described in section 4947

The following chart shows types of payments that may be exempt from backup withholding. The chart applies to the exempt payees listed above, 1 through 13.

IF the payment is for . . .	THEN the payment is exempt for . . .
Interest and dividend payments	All exempt payees except for 7
Broker transactions	Exempt payees 1 through 4 and 6 through 11 and all C corporations. S corporations must not enter an exempt payee code because they are exempt only for sales of noncovered securities acquired prior to 2012.
Barter exchange transactions and patronage dividends	Exempt payees 1 through 4
Payments over \$600 required to be reported and direct sales over \$5,000 ¹	Generally, exempt payees 1 through 5 ²
Payments made in settlement of payment card or third party network transactions	Exempt payees 1 through 4

¹ See Form 1099-MISC, Miscellaneous Income, and its instructions.

² However, the following payments made to a corporation and reportable on Form 1099-MISC are not exempt from backup withholding: medical and health care payments, attorneys' fees, gross proceeds paid to an attorney reportable under section 6045(f), and payments for services paid by a federal executive agency.

Exemption from FATCA reporting code. The following codes identify payees that are exempt from reporting under FATCA. These codes apply to persons submitting this form for accounts maintained outside of the United States by certain foreign financial institutions. Therefore, if you are only submitting this form for an account you hold in the United States, you may leave this field blank. Consult with the person requesting this form if you are uncertain if the financial institution is subject to these requirements. A requester may indicate that a code is not required by providing you with a Form W-9 with "Not Applicable" (or any similar indication) written or printed on the line for a FATCA exemption code.

- A—An organization exempt from tax under section 501(a) or any individual retirement plan as defined in section 7701(a)(37)
- B—The United States or any of its agencies or instrumentalities
- C—A state, the District of Columbia, a U.S. commonwealth or possession, or any of their political subdivisions or instrumentalities
- D—A corporation the stock of which is regularly traded on one or more established securities markets, as described in Regulations section 1.1472-1(c)(1)(i)
- E—A corporation that is a member of the same expanded affiliated group as a corporation described in Regulations section 1.1472-1(c)(1)(i)
- F—A dealer in securities, commodities, or derivative financial instruments (including notional principal contracts, futures, forwards, and options) that is registered as such under the laws of the United States or any state
- G—A real estate investment trust
- H—A regulated investment company as defined in section 851 or an entity registered at all times during the tax year under the Investment Company Act of 1940
- I—A common trust fund as defined in section 584(a)
- J—A bank as defined in section 581
- K—A broker
- L—A trust exempt from tax under section 664 or described in section 4947(a)(1)
- M—A tax exempt trust under a section 403(b) plan or section 457(g) plan

Note. You may wish to consult with the financial institution requesting this form to determine whether the FATCA code and/or exempt payee code should be completed.

Line 5

Enter your address (number, street, and apartment or suite number). This is where the requester of this Form W-9 will mail your information returns.

Line 6

Enter your city, state, and ZIP code.

Part I. Taxpayer Identification Number (TIN)

Enter your TIN in the appropriate box. If you are a resident alien and you do not have and are not eligible to get an SSN, your TIN is your IRS individual taxpayer identification number (ITIN). Enter it in the social security number box. If you do not have an ITIN, see *How to get a TIN* below.

If you are a sole proprietor and you have an EIN, you may enter either your SSN or EIN. However, the IRS prefers that you use your SSN.

If you are a single-member LLC that is disregarded as an entity separate from its owner (see *Limited Liability Company (LLC)* on this page), enter the owner's SSN (or EIN, if the owner has one). Do not enter the disregarded entity's EIN. If the LLC is classified as a corporation or partnership, enter the entity's EIN.

Note. See the chart on page 4 for further clarification of name and TIN combinations.

How to get a TIN. If you do not have a TIN, apply for one immediately. To apply for an SSN, get Form SS-5, Application for a Social Security Card, from your local SSA office or get this form online at www.ssa.gov. You may also get this form by calling 1-800-772-1213. Use Form W-7, Application for IRS Individual Taxpayer Identification Number, to apply for an ITIN, or Form SS-4, Application for Employer Identification Number, to apply for an EIN. You can apply for an EIN online by accessing the IRS website at www.irs.gov/businesses and clicking on Employer Identification Number (EIN) under Starting a Business. You can get Forms W-7 and SS-4 from the IRS by visiting IRS.gov or by calling 1-800-TAX-FORM (1-800-829-3676).

If you are asked to complete Form W-9 but do not have a TIN, apply for a TIN and write "Applied For" in the space for the TIN, sign and date the form, and give it to the requester. For interest and dividend payments, and certain payments made with respect to readily tradable instruments, generally you will have 60 days to get a TIN and give it to the requester before you are subject to backup withholding on payments. The 60-day rule does not apply to other types of payments. You will be subject to backup withholding on all such payments until you provide your TIN to the requester.

Note. Entering "Applied For" means that you have already applied for a TIN or that you intend to apply for one soon.

Caution: A disregarded U.S. entity that has a foreign owner must use the appropriate Form W-8.

Part II. Certification

To establish to the withholding agent that you are a U.S. person, or resident alien, sign Form W-9. You may be requested to sign by the withholding agent even if items 1, 4, or 5 below indicate otherwise.

For a joint account, only the person whose TIN is shown in Part I should sign (when required). In the case of a disregarded entity, the person identified on line 1 must sign. Exempt payees, see *Exempt payee code* earlier.

Signature requirements. Complete the certification as indicated in items 1 through 5 below.

1. **Interest, dividend, and barter exchange accounts opened before 1984 and broker accounts considered active during 1983.** You must give your correct TIN, but you do not have to sign the certification.
2. **Interest, dividend, broker, and barter exchange accounts opened after 1983 and broker accounts considered inactive during 1983.** You must sign the certification or backup withholding will apply. If you are subject to backup withholding and you are merely providing your correct TIN to the requester, you must cross out item 2 in the certification before signing the form.
3. **Real estate transactions.** You must sign the certification. You may cross out item 2 of the certification.
4. **Other payments.** You must give your correct TIN, but you do not have to sign the certification unless you have been notified that you have previously given an incorrect TIN. "Other payments" include payments made in the course of the requester's trade or business for rents, royalties, goods (other than bills for merchandise), medical and health care services (including payments to corporations), payments to a nonemployee for services, payments made in settlement of payment card and third party network transactions, payments to certain fishing boat crew members and fishermen, and gross proceeds paid to attorneys (including payments to corporations).
5. **Mortgage interest paid by you, acquisition or abandonment of secured property, cancellation of debt, qualified tuition program payments (under section 529), IRA, Coverdell ESA, Archer MSA or HSA contributions or distributions, and pension distributions.** You must give your correct TIN, but you do not have to sign the certification.

What Name and Number To Give the Requester

For this type of account:	Give name and SSN of:
1. Individual	The individual
2. Two or more individuals (joint account)	The actual owner of the account or, if combined funds, the first individual on the account ¹
3. Custodian account of a minor (Uniform Gift to Minors Act)	The minor ²
4. a. The usual revocable savings trust (grantor is also trustee) b. So-called trust account that is not a legal or valid trust under state law	The grantor-trustee ¹ The actual owner ¹
5. Sole proprietorship or disregarded entity owned by an individual	The owner ¹
6. Grantor trust filing under Optional Form 1099 Filing Method 1 (see Regulations section 1.671-4(b)(2)(i)(A))	The grantor ¹
For this type of account:	Give name and EIN of:
7. Disregarded entity not owned by an individual	The owner
8. A valid trust, estate, or pension trust	Legal entity ⁴
9. Corporation or LLC electing corporate status on Form 8832 or Form 2553	The corporation
10. Association, club, religious, charitable, educational, or other tax-exempt organization	The organization
11. Partnership or multi-member LLC	The partnership
12. A broker or registered nominee	The broker or nominee
13. Account with the Department of Agriculture in the name of a public entity (such as a state or local government, school district, or prison) that receives agricultural program payments	The public entity
14. Grantor trust filing under the Form 1041 Filing Method or the Optional Form 1099 Filing Method 2 (see Regulations section 1.671-4(b)(2)(i)(B))	The trust

¹ List first and circle the name of the person whose number you furnish. If only one person on a joint account has an SSN, that person's number must be furnished.
² Circle the minor's name and furnish the minor's SSN.

³ You must show your individual name and you may also enter your business or DBA name on the "Business name/disregarded entity" name line. You may use either your SSN or EIN (if you have one), but the IRS encourages you to use your SSN.
⁴ List first and circle the name of the trust, estate, or pension trust. (Do not furnish the TIN of the personal representative or trustee unless the legal entity itself is not designated in the account title.) Also see *Special rules for partnerships* on page 2.
 *Note. Grantor also must provide a Form W-9 to trustee of trust.

Note. If no name is circled when more than one name is listed, the number will be considered to be that of the first name listed.

Secure Your Tax Records from Identity Theft

Identity theft occurs when someone uses your personal information such as your name, SSN, or other identifying information, without your permission, to commit fraud or other crimes. An identity thief may use your SSN to get a job or may file a tax return using your SSN to receive a refund.

- To reduce your risk:
- Protect your SSN,
 - Ensure your employer is protecting your SSN, and
 - Be careful when choosing a tax preparer.

If your tax records are affected by identity theft and you receive a notice from the IRS, respond right away to the name and phone number printed on the IRS notice or letter.

If your tax records are not currently affected by identity theft but you think you are at risk due to a lost or stolen purse or wallet, questionable credit card activity or credit report, contact the IRS Identity Theft Hotline at 1-800-908-4490 or submit Form 14039.

For more information, see Publication 4535, Identity Theft Prevention and Victim Assistance.

Victims of identity theft who are experiencing economic harm or a system problem, or are seeking help in resolving tax problems that have not been resolved through normal channels, may be eligible for Taxpayer Advocate Service (TAS) assistance. You can reach TAS by calling the TAS toll-free case intake line at 1-877-777-4778 or TTY/TDD 1-800-829-4059.

Protect yourself from suspicious emails or phishing schemes. Phishing is the creation and use of email and websites designed to mimic legitimate business emails and websites. The most common act is sending an email to a user falsely claiming to be an established legitimate enterprise in an attempt to scam the user into surrendering private information that will be used for identity theft.

The IRS does not initiate contacts with taxpayers via emails. Also, the IRS does not request personal detailed information through email or ask taxpayers for the PIN numbers, passwords, or similar secret access information for their credit card, bank, or other financial accounts.

If you receive an unsolicited email claiming to be from the IRS, forward this message to phishing@irs.gov. You may also report misuse of the IRS name, logo, or other IRS property to the Treasury Inspector General for Tax Administration (TIGTA) at 1-800-366-4484. You can forward suspicious emails to the Federal Trade Commission at: spam@uce.gov or contact them at www.ftc.gov/idtheft or 1-877-IDTHEFT (1-877-438-4338).

Visit IRS.gov to learn more about identity theft and how to reduce your risk.

Privacy Act Notice

Section 6109 of the Internal Revenue Code requires you to provide your correct TIN to persons (including federal agencies) who are required to file information returns with the IRS to report interest, dividends, or certain other income paid to you; mortgage interest you paid; the acquisition or abandonment of secured property; the cancellation of debt; or contributions you made to an IRA, Archer MSA, or HSA. The person collecting this form uses the information on the form to file information returns with the IRS, reporting the above information. Routine uses of this information include giving it to the Department of Justice for civil and criminal litigation and to cities, states, the District of Columbia, and U.S. commonwealths and possessions for use in administering their laws. The information also may be disclosed to other countries under a treaty, to federal and state agencies to enforce civil and criminal laws, or to federal law enforcement and intelligence agencies to combat terrorism. You must provide your TIN whether or not you are required to file a tax return. Under section 3406, payers must generally withhold a percentage of taxable interest, dividend, and certain other payments to a payee who does not give a TIN to the payer. Certain penalties may also apply for providing false or fraudulent information.

RE: Notice of Award for IFB-PAG-013-024 Re-bid 180' Telescopic Boom Lift

From : MJ Camacho <mjgarcia@portofguam.com>
Subject : RE: Notice of Award for IFB-PAG-013-024 Re-bid 180'
Telescopic Boom Lift
To : 'Mark A. Cabrera' <macabrera@portofguam.com>

Thu, May 30, 2024 09:28 AM

📎 6 attachments

Mark,

Vendor Number is 333611. Thank you!



Mary Jane G. Camacho
General Accounting Supervisor

Port Authority of Guam
1026 Cabras Highway Suite 201 Piti, Guam 96915
mjgarcia@portofguam.com
(671) 477-5931 ext. 220

From: Mark A. Cabrera [mailto:macabrera@portofguam.com]
Sent: Wednesday, May 29, 2024 9:41 AM
To: Pete Pierson <pete@federalcontractscorp.com>
Cc: MaryJane Garcia <mjgarcia@portofguam.com>
Subject: Re: Notice of Award for IFB-PAG-013-024 Re-bid 180' Telescopic Boom Lift

Good Morning Mr. Pierson,

Thank you for the quick response. I will provide to our Finance Department so that a vendor number is assigned and we can proceed with the contract and purchase order.

For now, this is all we need. Will get back to you soon.

Best Regards,

Mark A. Cabrera
Procurement Buyer Supervisor



Port Authority of Guam
1026 Cabras Highway
Suite 201 Piti GU 96915

(671)477-5931 ext. 252
macabrera@portofguam.com

From: "Pete Pierson" <pete@federalcontractscorp.com>
To: "Mark A. Cabrera" <macabrera@portofguam.com>
Sent: Wednesday, May 29, 2024 5:53:39 AM
Subject: RE: Notice of Award for IFB-PAG-013-024 Re-bid 180' Telescopic Boom Lift

Hello Mark,

Attached is our W-9 and business license. Our EIN # is 42-1613127.

Please let me know if you need anything else.

Thank you,

Pete



Pete Pierson, Vice President
PH: 813.631.0000 FX: 813.631.0008
pete@federalcontractscorp.com

GSA & DLA Contract Holder
"Keeping Government Purchasing Simple"
Service Disabled Veteran Owned Small Business, HUBZone Vendor

From: Mark A. Cabrera <macabrera@portofguam.com>
Sent: Monday, May 27, 2024 9:25 PM
To: Pete Pierson <pete@federalcontractscorp.com>
Subject: Re: Notice of Award for IFB-PAG-013-024 Re-bid 180' Telescopic Boom Lift

Hello Mr. Peirson-

Can you provide me with a current copy of your business license and W-9 with EIN#? We need to register Pacific Federal Contracts Corporation as a Port vendor before I can process a purchase order or contract.

Thank You,

Mark A. Cabrera
Procurement Buyer Supervisor



Port Authority of Guam
1026 Cabras Highway
Suite 201 Piti GU 96915
(671)477-5931 ext. 252
macabrera@portofguam.com

From: "Mark A. Cabrera" <macabrera@portofguam.com>
To: "Pete Pierson" <pete@federalcontractscorp.com>
Sent: Tuesday, May 28, 2024 10:22:02 AM
Subject: Re: Notice of Award for IFB-PAG-013-024 Re-bid 180' Telescopic Boom Lift

Mr. Pierson,

Thank you for your quick response. We are preparing the purchase order. I will indicate 180 days delivery on it and will also include the contract cover which is the page from the solicitation that you had acknowledged. Needless to say, the Port is excited regarding this Procurement.

Respectfully,

Mark A. Cabrera
Procurement Buyer Supervisor



Port Authority of Guam
1026 Cabras Highway
Suite 201 Piti GU 96915
(671)477-5931 ext. 252
macabrera@portofguam.com

From: "Pete Pierson" <pete@federalcontractscorp.com>
To: "Mark A. Cabrera" <macabrera@portofguam.com>
Sent: Thursday, May 23, 2024 3:51:43 AM
Subject: RE: Notice of Award for IFB-PAG-013-024 Re-bid 180' Telescopic Boom Lift

Mark,

The lead time right now is 5 month ARO, plus transit time. I would say 30 days transit time to be safe. 180 days total to deliver.

Thank you,

Pete



Pete Pierson, Vice President
PH: 813.631.0000 FX: 813.631.0008
pete@federalcontractscorp.com

GSA & DLA Contract Holder
"Keeping Government Purchasing Simple"
Service Disabled Veteran Owned Small Business, HUBZone Vendor

From: Mark A. Cabrera <macabrera@portofguam.com>
Sent: Tuesday, May 21, 2024 10:09 PM
To: Pete Pierson <pete@federalcontractscorp.com>
Subject: Re: Notice of Award for IFB-PAG-013-024 Re-bid 180' Telescopic Boom Lift

Mr. Pierson-

Just wanted to confirm with you if Federal Contracts Corp can deliver within 150 days as noted in your bid submittal? The documents to award are being prepared and should be issued to you very soon.

Respectfully,

Mark A. Cabrera
Procurement Buyer Supervisor



Port Authority of Guam
1026 Cabras Highway
Suite 201 Piti GU 96915
(671)477-5931 ext. 252
macabrera@portofguam.com

From: "Pete Pierson" <pete@federalcontractscorp.com>
To: "Mark A. Cabrera" <macabrera@portofguam.com>
Cc: "Annie Sablan" <algsablan@portofguam.com>
Sent: Tuesday, May 21, 2024 10:09:17 PM
Subject: RE: Notice of Award for IFB-PAG-013-024 Re-bid 180' Telescopic Boom Lift

Hello,

We greatly appreciate your consideration and acknowledge your request.

Thank you,

Pete



Pete Pierson, Vice President
PH: 813.631.0000 FX: 813.631.0008
pete@federalcontractscorp.com

GSA & DLA Contract Holder
"Keeping Government Purchasing Simple"
Service Disabled Veteran Owned Small Business, *HUBZone Vendor*

From: Mark A. Cabrera <macabrera@portofguam.com>
Sent: Tuesday, May 21, 2024 2:01 AM
To: Pete Pierson <pete@federalcontractscorp.com>
Cc: algsablan <algsablan@portofguam.com>
Subject: Notice of Award for IFB-PAG-013-024 Re-bid 180' Telescopic Boom Lift

Hafa Adai Mr. Pierson-

Congratulations! Kindly acknowledge the attached request so that we may move forward with the Procurement process.

Thank You,

Mark A. Cabrera
Procurement Buyer Supervisor



Port Authority of Guam
1026 Cabras Highway
Suite 201 Piti GU 96915
(671)477-5931 ext. 252
macabrera@portofguam.com

Re: Notice of Award for IFB-PAG-013-024 Re-bid 180' Telescopic Boom Lift

From : Mark A. Cabrera <macabrera@portofguam.com> Thu, May 30, 2024 01:50 PM
Subject : Re: Notice of Award for IFB-PAG-013-024 Re-bid 180' Telescopic Boom Lift 6 attachments
To : MaryJane Garcia <mjgarcia@portofguam.com>

Hi MJ-

Thanks so much. I will be processing the order shortly.

Thank You,
Mark

From: "MaryJane Garcia" <mjgarcia@portofguam.com>
To: "Mark A. Cabrera" <macabrera@portofguam.com>
Sent: Thursday, May 30, 2024 9:28:16 AM
Subject: RE: Notice of Award for IFB-PAG-013-024 Re-bid 180' Telescopic Boom Lift

Mark,

Vendor Number is 333611. Thank you!



Mary Jane G. Camacho
General Accounting Supervisor

Port Authority of Guam
1026 Cabras Highway Suite 201 Piti, Guam 96915

mjgarcia@portofguam.com

(671) 477-5931 ext. 220

From: Mark A. Cabrera [mailto:macabrera@portofguam.com]
Sent: Wednesday, May 29, 2024 9:41 AM
To: Pete Pierson <pete@federalcontractscorp.com>
Cc: MaryJane Garcia <mjgarcia@portofguam.com>
Subject: Re: Notice of Award for IFB-PAG-013-024 Re-bid 180' Telescopic Boom Lift

Good Morning Mr. Pierson,

Thank you for the quick response. I will provide to our Finance Department so that a vendor number is assigned and we can proceed with the contract and purchase order.

For now, this is all we need. Will get back to you soon.

Best Regards,

Mark A. Cabrera
Procurement Buyer Supervisor



Port Authority of Guam
1026 Cabras Highway
Suite 201 Piti GU 96915
(671)477-5931 ext. 252
macabrera@portofguam.com

From: "Pete Pierson" <pete@federalcontractscorp.com>
To: "Mark A. Cabrera" <macabrera@portofguam.com>
Sent: Wednesday, May 29, 2024 5:53:39 AM
Subject: RE: Notice of Award for IFB-PAG-013-024 Re-bid 180' Telescopic Boom Lift

Hello Mark,

Attached is our W-9 and business license. Our EIN # is 42-1613127.

Please let me know if you need anything else.

Thank you,

Pete



Pete Pierson, Vice President
PH: 813.631.0000 FX: 813.631.0008
pete@federalcontractscorp.com

GSA & DLA Contract Holder
"Keeping Government Purchasing Simple"

Service Disabled Veteran Owned Small Business, HUBZone Vendor

From: Mark A. Cabrera <macabrera@portofguam.com>

Sent: Monday, May 27, 2024 9:25 PM

To: Pete Pierson <pete@federalcontractscorp.com>

Subject: Re: Notice of Award for IFB-PAG-013-024 Re-bid 180' Telescopic Boom Lift

Hello Mr. Peirson-

Can you provide me with a current copy of your business license and W-9 with EIN#? We need to register Pacific Federal Contracts Corporation as a Port vendor before I can process a purchase order or contract.

Thank You,

Mark A. Cabrera
Procurement Buyer Supervisor



Port Authority of Guam
1026 Cabras Highway
Suite 201 Piti GU 96915
(671)477-5931 ext. 252
macabrera@portofguam.com

From: "Mark A. Cabrera" <macabrera@portofguam.com>

To: "Pete Pierson" <pete@federalcontractscorp.com>

Sent: Tuesday, May 28, 2024 10:22:02 AM

Subject: Re: Notice of Award for IFB-PAG-013-024 Re-bid 180' Telescopic Boom Lift

Mr. Pierson,

Thank you for your quick response. We are preparing the purchase order. I will indicate 180 days delivery on it and will also include the contract cover which is the page from the solicitation that you had acknowledged. Needless to say, the Port is excited regarding this Procurement.

Respectfully,

Mark A. Cabrera
Procurement Buyer Supervisor



Port Authority of Guam
1026 Cabras Highway
Suite 201 Piti GU 96915
(671)477-5931 ext. 252
macabrera@portofguam.com

From: "Pete Pierson" <pete@federalcontractscorp.com>
To: "Mark A. Cabrera" <macabrera@portofguam.com>
Sent: Thursday, May 23, 2024 3:51:43 AM
Subject: RE: Notice of Award for IFB-PAG-013-024 Re-bid 180' Telescopic Boom Lift

Mark,

The lead time right now is 5 month ARO, plus transit time. I would say 30 days transit time to be safe. 180 days total to deliver.

Thank you,

Pete



Pete Pierson, Vice President
PH: 813.631.0000 FX: 813.631.0008
pete@federalcontractscorp.com

GSA & DLA Contract Holder
"Keeping Government Purchasing Simple"

Service Disabled Veteran Owned Small Business, *HUBZone Vendor*

From: Mark A. Cabrera <macabrera@portofguam.com>
Sent: Tuesday, May 21, 2024 10:09 PM
To: Pete Pierson <pete@federalcontractscorp.com>
Subject: Re: Notice of Award for IFB-PAG-013-024 Re-bid 180' Telescopic Boom Lift

Mr. Pierson-

Just wanted to confirm with you if Federal Contracts Corp can deliver within 150 days as noted in your bid submittal? The documents to award are being prepared and should be issued to you very soon.

Respectfully,

Mark A. Cabrera
Procurement Buyer Supervisor



Port Authority of Guam
1026 Cabras Highway
Suite 201 Piti GU 96915
(671)477-5931 ext. 252
macabrera@portofguam.com

From: "Pete Pierson" <pete@federalcontractscorp.com>
To: "Mark A. Cabrera" <macabrera@portofguam.com>
Cc: "Annie Sablan" <algsablan@portofguam.com>
Sent: Tuesday, May 21, 2024 10:09:17 PM
Subject: RE: Notice of Award for IFB-PAG-013-024 Re-bid 180' Telescopic Boom Lift

Hello,

We greatly appreciate your consideration and acknowledge your request.

Thank you,

Pete



Pete Pierson, Vice President
PH: 813.631.0000 FX: 813.631.0008
pete@federalcontractscorp.com

GSA & DLA Contract Holder
"Keeping Government Purchasing Simple"
Service Disabled Veteran Owned Small Business, HUBZone Vendor

From: Mark A. Cabrera <macabrera@portofguam.com>
Sent: Tuesday, May 21, 2024 2:01 AM
To: Pete Pierson <pete@federalcontractscorp.com>

Cc: algsablan <algsablan@portofguam.com>

Subject: Notice of Award for IFB-PAG-013-024 Re-bid 180' Telescopic Boom Lift

Hafa Adai Mr. Pierson-

Congratulations! Kindly acknowledge the attached request so that we may move forward with the Procurement process.

Thank You,

Mark A. Cabrera
Procurement Buyer Supervisor



Port Authority of Guam
1026 Cabras Highway
Suite 201 Piti GU 96915
(671)477-5931 ext. 252
macabrera@portofguam.com

Re: Notice of Award for IFB-PAG-013-024 Re-bid 180' Telescopic Boom Lift

From : Mark A. Cabrera <macabrera@portofguam.com> Wed, Jun 05, 2024 10:39 AM
Subject : Re: Notice of Award for IFB-PAG-013-024 Re-bid 180' Telescopic Boom Lift 5 attachments
To : Pete Pierson <pete@federalcontractscorp.com>

Good Morning Mr. Pierson,

We are near the finalization of the Contract and Purchase Order. The attachments are required to be filled out as this award is provided through a Federal Grant. Simultaneously, I will be processing your order and contract in the amount of \$517,205.41. A four percent 4% (\$20,688.22) Withholding Assessment Fee will be applied against the amount, this will be stated on the order and be retained at payment to Federal Contracts Corporation.

The confirmed delivery will read: 180 days as you had indicated in your earlier e-mail. A copy of the contract and purchase order will be sent to you once signed.

Respectfully,

Mark A. Cabrera
Procurement Buyer Supervisor



Port Authority of Guam
1026 Cabras Highway
Suite 201 Piti GU 96915
(671)477-5931 ext. 252
macabrera@portofguam.com

From: "Pete Pierson" <pete@federalcontractscorp.com>
To: "Mark A. Cabrera" <macabrera@portofguam.com>
Sent: Wednesday, May 29, 2024 5:53:39 AM
Subject: RE: Notice of Award for IFB-PAG-013-024 Re-bid 180' Telescopic Boom Lift

Hello Mark,

Attached is our W-9 and business license. Our EIN # is 42-1613127.

Please let me know if you need anything else.

Thank you,

Pete



Pete Pierson, Vice President

PH: 813.631.0000 FX: 813.631.0008

pete@federalcontractscorp.com

GSA & DLA Contract Holder

"Keeping Government Purchasing Simple"

Service Disabled Veteran Owned Small Business, *HUBZone Vendor*

From: Mark A. Cabrera <macabrera@portofguam.com>

Sent: Monday, May 27, 2024 9:25 PM

To: Pete Pierson <pete@federalcontractscorp.com>

Subject: Re: Notice of Award for IFB-PAG-013-024 Re-bid 180' Telescopic Boom Lift

Hello Mr. Peirson-

Can you provide me with a current copy of your business license and W-9 with EIN#? We need to register Pacific Federal Contracts Corporation as a Port vendor before I can process a purchase order or contract.

Thank You,

Mark A. Cabrera
Procurement Buyer Supervisor



Port Authority of Guam
1026 Cabras Highway
Suite 201 Piti GU 96915
(671)477-5931 ext. 252
macabrera@portofguam.com

From: "Mark A. Cabrera" <macabrera@portofguam.com>
To: "Pete Pierson" <pete@federalcontractscorp.com>
Sent: Tuesday, May 28, 2024 10:22:02 AM
Subject: Re: Notice of Award for IFB-PAG-013-024 Re-bid 180' Telescopic Boom Lift

Mr. Pierson,

Thank you for your quick response. We are preparing the purchase order. I will indicate 180 days delivery on it and will also include the contract cover which is the page from the solicitation that you had acknowledged. Needless to say, the Port is excited regarding this Procurement.

Respectfully,

Mark A. Cabrera
Procurement Buyer Supervisor



Port Authority of Guam
1026 Cabras Highway
Suite 201 Piti GU 96915
(671)477-5931 ext. 252
macabrera@portofguam.com

From: "Pete Pierson" <pete@federalcontractscorp.com>
To: "Mark A. Cabrera" <macabrera@portofguam.com>
Sent: Thursday, May 23, 2024 3:51:43 AM
Subject: RE: Notice of Award for IFB-PAG-013-024 Re-bid 180' Telescopic Boom Lift

Mark,

The lead time right now is 5 month ARO, plus transit time. I would say 30 days transit time to be safe. 180 days total to deliver.

Thank you,

Pete



Pete Pierson, Vice President

PH: 813.631.0000 FX: 813.631.0008

pete@federalcontractscorp.com

GSA & DLA Contract Holder

"Keeping Government Purchasing Simple"

Service Disabled Veteran Owned Small Business, *HUBZone Vendor*

From: Mark A. Cabrera <macabrera@portofguam.com>

Sent: Tuesday, May 21, 2024 10:09 PM

To: Pete Pierson <pete@federalcontractscorp.com>

Subject: Re: Notice of Award for IFB-PAG-013-024 Re-bid 180' Telescopic Boom Lift

Mr. Pierson-

Just wanted to confirm with you if Federal Contracts Corp can deliver within 150 days as noted in your bid submittal? The documents to award are being prepared and should be issued to you very soon.

Respectfully,

Mark A. Cabrera
Procurement Buyer Supervisor



Port Authority of Guam
1026 Cabras Highway
Suite 201 Piti GU 96915

(671)477-5931 ext. 252
macabrera@portofguam.com

From: "Pete Pierson" <pete@federalcontractscorp.com>
To: "Mark A. Cabrera" <macabrera@portofguam.com>
Cc: "Annie Sablan" <algsablan@portofguam.com>
Sent: Tuesday, May 21, 2024 10:09:17 PM
Subject: RE: Notice of Award for IFB-PAG-013-024 Re-bid 180' Telescopic Boom Lift

Hello,

We greatly appreciate your consideration and acknowledge your request.

Thank you,

Pete



Pete Pierson, Vice President

PH: 813.631.0000 FX: 813.631.0008

pete@federalcontractscorp.com

GSA & DLA Contract Holder

"Keeping Government Purchasing Simple"

Service Disabled Veteran Owned Small Business, *HUBZone Vendor*

From: Mark A. Cabrera <macabrera@portofguam.com>
Sent: Tuesday, May 21, 2024 2:01 AM
To: Pete Pierson <pete@federalcontractscorp.com>
Cc: algsablan <algsablan@portofguam.com>
Subject: Notice of Award for IFB-PAG-013-024 Re-bid 180' Telescopic Boom Lift

Hafa Adai Mr. Pierson-

Congratulations! Kindly acknowledge the attached request so that we may move forward with the Procurement process.

Thank You,

Mark A. Cabrera
Procurement Buyer Supervisor



Port Authority of Guam
1026 Cabras Highway
Suite 201 Piti GU 96915
(671)477-5931 ext. 252
macabrera@portofguam.com



logo.jpeg
14 KB

-  **Attachment B; Conflict of Interest Instructions and Form.pdf**
733 KB

 -  **Attachment A - Telescopic Boom.pdf**
307 KB
-

Re: Notice of Award for IFB-PAG-013-024 Re-bid 180' Telescopic Boom Lift

From : Mark A. Cabrera <macabrera@portofguam.com> Thu, Jun 06, 2024 03:10 PM
Subject : Re: Notice of Award for IFB-PAG-013-024 Re-bid 180' Telescopic Boom Lift 6 attachments
To : Pete Pierson <pete@federalcontractscorp.com>
Cc : algsablan <algsablan@portofguam.com>, Steven P. Muna <spmuna01@portofguam.com>, Pia A. Castro <pacastro@portofguam.com>

Good Afternoon Mr. Pierson,

Congratulations on your award!!!

Attached is the IFB Contract in which requires your signature for the agreement. Also included is the purchase order that requires your acknowledgment on the second page. Last, I'm still pending the COI and Anti-Lobbying disclosure forms from you, but we can receive them from you all at once. Let me know if you have any questions. Thank You.

Respectfully,

Mark A. Cabrera
Procurement Buyer Supervisor



Port Authority of Guam
1026 Cabras Highway
Suite 201 Piti GU 96915
(671)477-5931 ext. 252
macabrera@portofguam.com

From: "Mark A. Cabrera" <macabrera@portofguam.com>
To: "Pete Pierson" <pete@federalcontractscorp.com>
Sent: Wednesday, June 5, 2024 10:39:17 AM
Subject: Re: Notice of Award for IFB-PAG-013-024 Re-bid 180' Telescopic Boom Lift

Good Morning Mr. Pierson,

We are near the finalization of the Contract and Purchase Order. The attachments are required to be filled out as this award is provided through a Federal Grant. Simultaneously, I will be processing your order and contract in the amount of \$517,205.41. A four percent 4% (\$20,688.22) Withholding Assessment Fee will be applied against the amount, this will be stated on the order and be retained at payment to Federal Contracts Corporation.

The confirmed delivery will read: 180 days as you had indicated in your earlier e-mail. A copy of the contract and purchase order will be sent to you once signed.

Respectfully,

Mark A. Cabrera
Procurement Buyer Supervisor



Port Authority of Guam
1026 Cabras Highway
Suite 201 Piti GU 96915
(671)477-5931 ext. 252
macabrera@portofguam.com

From: "Pete Pierson" <pete@federalcontractscorp.com>
To: "Mark A. Cabrera" <macabrera@portofguam.com>
Sent: Wednesday, May 29, 2024 5:53:39 AM
Subject: RE: Notice of Award for IFB-PAG-013-024 Re-bid 180' Telescopic Boom Lift

Hello Mark,

Attached is our W-9 and business license. Our EIN # is 42-1613127.

Please let me know if you need anything else.

Thank you,

Pete



Pete Pierson, Vice President

PH: 813.631.0000 FX: 813.631.0008

pete@federalcontractscorp.com

GSA & DLA Contract Holder

"Keeping Government Purchasing Simple"

Service Disabled Veteran Owned Small Business, *HUBZone Vendor*

From: Mark A. Cabrera <macabrera@portofguam.com>

Sent: Monday, May 27, 2024 9:25 PM

To: Pete Pierson <pete@federalcontractscorp.com>

Subject: Re: Notice of Award for IFB-PAG-013-024 Re-bid 180' Telescopic Boom Lift

Hello Mr. Peirson-

Can you provide me with a current copy of your business license and W-9 with EIN#? We need to register Pacific Federal Contracts Corporation as a Port vendor before I can process a purchase order or contract.

Thank You,

Mark A. Cabrera
Procurement Buyer Supervisor



Port Authority of Guam
1026 Cabras Highway
Suite 201 Piti GU 96915
(671)477-5931 ext. 252
macabrera@portofguam.com

From: "Mark A. Cabrera" <macabrera@portofguam.com>
To: "Pete Pierson" <pete@federalcontractscorp.com>
Sent: Tuesday, May 28, 2024 10:22:02 AM
Subject: Re: Notice of Award for IFB-PAG-013-024 Re-bid 180' Telescopic Boom Lift

Mr. Pierson,

Thank you for your quick response. We are preparing the purchase order. I will indicate 180 days delivery on it and will also include the contract cover which is the page from the solicitation that you had acknowledged. Needless to say, the Port is excited regarding this Procurement.

Respectfully,

Mark A. Cabrera
Procurement Buyer Supervisor



Port Authority of Guam
1026 Cabras Highway
Suite 201 Piti GU 96915
(671)477-5931 ext. 252

macabrera@portofguam.com

From: "Pete Pierson" <pete@federalcontractscorp.com>
To: "Mark A. Cabrera" <macabrera@portofguam.com>
Sent: Thursday, May 23, 2024 3:51:43 AM
Subject: RE: Notice of Award for IFB-PAG-013-024 Re-bid 180' Telescopic Boom Lift

Mark,

The lead time right now is 5 month ARO, plus transit time. I would say 30 days transit time to be safe. 180 days total to deliver.

Thank you,

Pete



Pete Pierson, Vice President

PH: 813.631.0000 FX: 813.631.0008

pete@federalcontractscorp.com

GSA & DLA Contract Holder

"Keeping Government Purchasing Simple"

Service Disabled Veteran Owned Small Business, *HUBZone Vendor*

From: Mark A. Cabrera <macabrera@portofguam.com>

Sent: Tuesday, May 21, 2024 10:09 PM

To: Pete Pierson <pete@federalcontractscorp.com>

Subject: Re: Notice of Award for IFB-PAG-013-024 Re-bid 180' Telescopic Boom Lift

Mr. Pierson-

Just wanted to confirm with you if Federal Contracts Corp can deliver within 150 days as noted in your bid submittal? The documents to award are being prepared and should be issued to you very soon.

Respectfully,

Mark A. Cabrera
Procurement Buyer Supervisor



Port Authority of Guam
1026 Cabras Highway
Suite 201 Piti GU 96915
(671)477-5931 ext. 252
macabrera@portofguam.com

From: "Pete Pierson" <pete@federalcontractscorp.com>

To: "Mark A. Cabrera" <macabrera@portofguam.com>

Cc: "Annie Sablan" <algsablan@portofguam.com>

Sent: Tuesday, May 21, 2024 10:09:17 PM

Subject: RE: Notice of Award for IFB-PAG-013-024 Re-bid 180' Telescopic Boom Lift

Hello,

We greatly appreciate your consideration and acknowledge your request.

Thank you,

Pete



Pete Pierson, Vice President

PH: 813.631.0000 FX: 813.631.0008

pete@federalcontractscorp.com

GSA & DLA Contract Holder

"Keeping Government Purchasing Simple"

Service Disabled Veteran Owned Small Business, *HUBZone Vendor*

From: Mark A. Cabrera <macabrera@portofguam.com>

Sent: Tuesday, May 21, 2024 2:01 AM

To: Pete Pierson <pete@federalcontractscorp.com>

Cc: algsablan <algsablan@portofguam.com>

Subject: Notice of Award for IFB-PAG-013-024 Re-bid 180' Telescopic Boom Lift

Hafa Adai Mr. Pierson-

Congratulations! Kindly acknowledge the attached request so that we may move forward with the Procurement process.

Thank You,

Mark A. Cabrera
Procurement Buyer Supervisor



Port Authority of Guam
1026 Cabras Highway
Suite 201 Piti GU 96915
(671)477-5931 ext. 252
macabrera@portofguam.com



 **Contract IFB-PAG-013-24.pdf**
2 MB

 **Purchase Order 19901-OS.pdf**
1 MB

FCDN-2-2-166 (APPROVED 10/66)
 INDICATE METHOD BY NUMBER
 03 OTHER CONTRACTUAL SERVICES
 04 SUPPLIES & MATERIALS
 05 EQUIPMENT
 XX MISCELLANEOUS

PURCHASE ORDER

 PORT AUTHORITY OF GUAM
 1026 CABRAS HIGHWAY SUITE 201
 PITI, GUAM 96925

PURCHASE ORDER
 NO: **199010S**
 This number must appear on all packages and papers pertaining to this order.

ID #98-0020236

Date: 2024-06-05

REQUISITION NUMBER: 00021658 ON **ALLOTMENT: C23F003.1782.1**

TO: S E L L E R	Federal Contracts Corp. 12918 N. Nebraska Ave. Tampa FL 33612	S H I P T O	Consignee, Destination and Marking PORT AUTHORITY OF GUAM 1026 CABRAS HIGHWAY SUITE 201 PITI, GUAM 96925
--	---	--	--

Invitation No.	Contract No.	Time for Delivery	Expiring	Discount Terms
----------------	--------------	-------------------	----------	----------------

Delivery F.O.B.	Shipping Point	Ship Via	B.L. NO.
-----------------	----------------	----------	----------

Line	ARTICLES OR SERVICES	Qty	Unit	Unit Price	Amount
1.000	TELSCOPIC BOOM LIFT - Award of IFB-PAG-013-24 180 Telescopic Boom Lift Government of Guam Withholding Assessment Fee 4%: \$20,688.22 Point of Contact: JACQUE CRUZ, RAYMOND SANTOS (671)477-5931/5 EXTENSIONS 295 OR 294. Authority Code: 3109 Delivery: 180 days ARO Must comply to all Bid Specification, Requirements, and PAG Federal Contracts Supplement as attached. *****NOTHING FOLLOWS*****	1	EA	517205.4100	517205.41

1. THE GOVERNMENT OF GUAM WILL NOT BE RESPONSIBLE FOR ANY UNAUTHORIZED PURCHASES OR SERVICES.
 2. DELIVER ALL MATERIALS TO PORT AUTHORITY OF GUAM SUPPLY WAREHOUSE 477-5931 X209/210.
 3. TO BE COORDINATED WITH AGENCY AND VENDOR.
 4. ALL LATE DELIVERIES AND ACCEPTANCES ARE SUBJECT TO THE LIQUIDATED DAMAGES CLAUSE IN SECTION 6101 (9)(a) OF THE GAR.
 5. SUBJECT TO ALL REQUIRED TERMS AND CONDITIONS OF THE PAG FEDERAL CONTRACT SUPPLEMENT ATTACHED HERETO.
 6. SUBJECT TO ALL REQUIRED TERMS AND CONDITIONS OF THE GUAM CONTRACT SUPPLEMENT ATTACHED HERETO

NOTE: AMOUNTS DUE THIS PURCHASE ORDER MAY BE OFF SET FOR MONIES DUE THE GOVERNMENT OF GUAM INCLUSIVE OF BUT NOT LIMITED TO TAXES, FEES, AND RETURNED CHECKS PLUS FEES, INTERESTS OR OTHER DAMAGES, PENALTIES, AND ATTORNEY'S FEES AFTER FAILURE TO PAY ACCORDING TO LAW.

Certified Funds Available  Authorized Certifying Officer Jose B. Guevara III, Chief Financial Officer				TOTAL	517205.41
---	--	--	--	--------------	-----------

ORIGINAL
 Contractor please supply promptly the above article or services. All correspondence pertaining to this order including invoices, shipping documents and packages must bear the Purchase Order number shown above. See reverse side for billing and shipping instructions.

 Signature
 RORY J. RESPIGIO, GENERAL MANAGER
 Name Title

FCDN-2-2-166 (APPROVED 10/66)
 INDICATE METHOD BY NUMBER
 03 OTHER CONTRACTUAL SERVICES
 04 SUPPLIES & MATERIALS
 05 EQUIPMENT
 XX MISCELLANEOUS

PURCHASE ORDER

 PORT AUTHORITY OF GUAM
 1026 CABRAS HIGHWAY SUITE 201
 PITI, GUAM 96925

PURCHASE ORDER
 NO: **199010S**
 This number must appear on all packages and papers pertaining to this order.

ID #98-0020236

Date: **2024-06-05**

REQUISITION NUMBER: 00021658 ON **ALLOTMENT: C23F003.1782.1**

TO: SELLER	Federal Contracts Corp. 12918 N. Nebraska Ave. Tampa FL 33612	SHIP TO	Consignee, Destination and Marking		
			PORT AUTHORITY OF GUAM 1026 CABRAS HIGHWAY SUITE 201 PITI, GUAM 96925		

Invitation No.	Contract No.	Time for Delivery	Expiring	Discount Terms
----------------	--------------	-------------------	----------	----------------

Delivery F.O.B.	Shipping Point	Ship Via	B.L. NO.
-----------------	----------------	----------	----------

Line	ARTICLES OR SERVICES	Qty	Unit	Unit Price	Amount
1.000	TELSCOPIC BOOM LIFT - Award of IFB-PAG-013-24 180 Telescopic Boom Lift Government of Guam Withholding Assessment Fee 4%: \$20,888.22 Point of Contact: JACQUE CRUZ, RAYMOND SANTOS (671)477-5931/5 EXTENSIONS 295 OR 294. Authority Code: 3109 Delivery: 180 days ARO Must comply to all Bid Specification, Requirements, and PAG Federal Contracts Supplement as attached. *****NOTHING FOLLOWS*****	1	EA	517205.4100	517205.41

1. THE GOVERNMENT OF GUAM WILL NOT BE RESPONSIBLE FOR ANY UNAUTHORIZED PURCHASES OR SERVICES.
 2. DELIVER ALL MATERIALS TO PORT AUTHORITY OF GUAM SUPPLY WAREHOUSE 477-5931 X209/210.
 3. TO BE COORDINATED WITH AGENCY AND VENDOR.
 4. ALL LATE DELIVERIES AND ACCEPTANCES ARE SUBJECT TO THE LIQUIDATED DAMAGES CLAUSE IN SECTION 6101 (9)(a) OF THE GAR.
 5. SUBJECT TO ALL REQUIRED TERMS AND CONDITIONS OF THE PAG FEDERAL CONTRACT SUPPLEMENT ATTACHED HERETO.
 6. SUBJECT TO ALL REQUIRED TERMS AND CONDITIONS OF THE GUAM CONTRACT SUPPLEMENT ATTACHED HERETO.

NOTE: AMOUNTS DUE THIS PURCHASE ORDER MAY BE OFF SET FOR MONIES DUE THE GOVERNMENT OF GUAM INCLUSIVE OF BUT NOT LIMITED TO TAXES, FEES, AND RETURNED CHECKS PLUS FEES, INTERESTS OR OTHER DAMAGES, PENALTIES, AND ATTORNEY'S FEES AFTER FAILURE TO PAY ACCORDING TO LAW.

Certified Funds Available				TOTAL	517205.41
 Authorized Certifying Officer Jose B. Guevara III, Chief Financial Officer					

ACKNOWLEDGEMENT COPY
 To: **PAG MANAGEMENT DIVISION**

DATE OF RECEIPT OF ORDER: _____

VENDOR SIGNATURE _____

	Signature
RORY J. RESPICTO, GENERAL MANAGER	
Name	Title

10b

PORT AUTHORITY OF GUAM FEDERAL CONTRACT SUPPLEMENT

All boxes marked below are terms and conditions applicable to the Agreement entered by the Port Authority of Guam ("PAG") and Contractor, which is funded in whole or in part by federal award funds, as supplemented with these federally required terms. To the extent that any of the contractual terms, provisions, or conditions of the Agreement are inconsistent with the applicable terms, provisions, or conditions of this Federal Contract Supplement, the applicable terms of this Federal Contract Supplement shall govern.

DOMESTIC PRODUCTS PREFERENCE

As appropriate and to the extent consistent with law, there is a preference for the purchase, acquisition, or use of goods, products, or materials produced in the United States (including but not limited to iron, aluminum, steel, cement, and other manufactured products). The requirements of this section must be included in all subcontracts, including all purchase orders for work or products under this subaward. For purposes of this section: "Produced in the United States" means, for iron and steel products, that all manufacturing processes, from the initial melting stage through the application of coatings, occurred in the United States.

PROHIBITION ON CERTAIN TELECOMMUNICATIONS AND VIDEO SURVEILLANCE SERVICES AND EQUIPMENT

For the purpose of public safety, security of government facilities, physical security surveillance of critical infrastructure, and other national security purposes, Contractor and all subcontractors are prohibited from procuring, obtaining, or purchasing: 1) equipment, services, or systems that uses covered telecommunications equipment or services as a substantial or essential component of any system, or as critical technology as part of any system. As described in Public Law 115-232, section 889, covered telecommunications equipment is telecommunications equipment produced by Huawei Technologies Company or ZTE Corporation (or any subsidiary or affiliate of such entities); 2) video surveillance and telecommunications equipment produced by Hytera Communications Corporation, Hangzhou Hikvision Digital Technology Company, or Dahua Technology Company (or any subsidiary or affiliate of such entities); 3) telecommunications or video surveillance services provided by such entities or using such equipment; and 4) telecommunications or video surveillance equipment or services produced or provided by an entity that the Secretary of Defense, in consultation with the Director of the National Intelligence or the Director of the Federal Bureau of Investigation, reasonably believes to be an entity owned or controlled by, or otherwise connected to, the government of a covered foreign country.

PROCUREMENT OF RECOVERED MATERIALS

Contractor and all subcontractors must comply with section 6002 of the Solid Waste Disposal Act, as amended by the Resource Conservation and Recovery Act. The requirements of Section 6002 include procuring only items designated in guidelines of the Environmental Protection Agency (EPA) at 40 CFR part 247 that contain the highest percentage of recovered materials practicable,

consistent with maintaining a satisfactory level of competition, where the purchase price of the item exceeds \$10,000 or the value of the quantity acquired during the preceding fiscal year exceeded \$10,000; procuring solid waste management services in a manner that maximizes energy and resource recovery; and establishing an affirmative procurement program for procurement of recovered materials identified in the EPA guidelines.

UNALLOWABLE COSTS

Contractor agrees to comply with all applicable laws, regulations, policies, and guidance (including specific cost limits, prior approval and reporting requirements, where applicable) governing the use of federal funds. Costs that are expressly unallowable under federal funding laws, or costs which specifically become designated as unallowable as a result of a written decision furnished by a contracting officer pursuant to contract dispute procedures, or costs which are mutually agreed to be unallowable, including mutually agreed to be unallowable directly associated costs, shall be identified and excluded from any invoice, billing, claim, or proposal applicable to a federally funded contract. A directly associated cost is any cost which is generated solely as a result of incurring another cost, and which would not have been incurred had the other cost not been incurred. When an unallowable cost is incurred, its directly associated costs are also unallowable. Contractor agrees to pay any penalties associated with any unallowable costs.

NO OBLIGATION BY THE FEDERAL GOVERNMENT

PAG and Contractor acknowledge and agree that, notwithstanding any concurrence by the Federal Government in or approval of the solicitation or award of the underlying Agreement, absent the express written consent by the Federal Government, the Federal Government is not a party to this contract and shall not be subject to any obligations or liabilities to PAG. Contractor, or any other party (whether or not a party to the contract) pertaining to any matter resulting from the underlying contract. Contractor agrees to include the above clause in each subcontract financed in whole or in part with Federal funds under this Agreement. It is further agreed that the clause shall not be modified, except to identify the subcontractor who will be subject to its provisions.

FEDERAL LOBBYING

The Contractor certifies, to the best of his or her knowledge and belief, that:

A. No Federal appropriated funds have been paid or will be paid, by or on behalf of the undersigned, to any person for influencing or attempting to influence an officer or employee of an agency, a Member of Congress, an officer or employee of Congress, or an employee of a Member of Congress in connection with the awarding of this Agreement, the making of any Federal grant, the making of any Federal loan, the entering into of any cooperative agreement, and the extension, continuation, renewal, amendment, or modification of this Agreement or any Federal grant, loan, or cooperative agreement.

B. If any funds other than Federal appropriated funds have been paid or will be paid to any person for making lobbying contacts to an officer or employee of any agency, a Member of Congress, an officer or employee of Congress, or an employee of a Member of Congress in connection with this Agreement, or any Federal grant, loan, or cooperative agreement, the undersigned shall complete and submit Standard Form--LLL, "Disclosure Form to Report Lobbying," in accordance with its instructions [as amended by "Government wide Guidance for New Restrictions on Lobbying," 61 Fed. Reg. 1413 (1/19/96). Note: Language in paragraph (2) herein has been modified in accordance with Section 10 of the Lobbying Disclosure Act of 1995 (P.L. 104-65, to be codified at 2 U.S.C. 1601, et seq.)]

C. The Contractor shall require that the language of this certification be included in the award documents for all subawards at all tiers (including subcontracts, subgrants, and contracts under grants, loans, and cooperative agreements) and that all subcontractors shall certify and disclose accordingly.

D. This certification is a material representation of fact upon which reliance was placed when this transaction was made or entered into. Submission of this certification is a prerequisite for making or entering into this Agreement. The Contractor certifies or affirms the truthfulness and accuracy of each statement of this certification and disclosure. In addition, the Contractor understands and agrees that the provisions of 31 U.S.C. A 3801, et seq., apply to this certification and disclosure.

ALL PUBLISHED ITEMS AND DELIVERABLES MUST INCLUDE NAME OF FEDERAL AWARDING AGENCY AND AWARD NUMBER

Contractor agrees to include the Program logo and the logos of the Federal Awarding Agency, the PAG, and the government of Guam on any materials developed for publication. Contractor further agrees to ensure statements, press releases, public service announcements, media interviews, requests for proposals, bid solicitations, and other documents or activities carried out in whole or part with program funds shall clearly state: (1) the dollar amount of federal funds for the project; (2) the Federal Award Number; and (3) the involvement of the Federal Awarding Agency, the PAG, and the government of Guam.

DEBARMENT (GUAM AND FEDERAL)

A. **Guam Debarment and Suspension.** Contractor warrants that it will comply with the provisions of 5 GCA Chapter 5 Articles 9 and 11, subject to debarment or suspension, and that it will not employ any subcontractors who have been federally debarred or debarred by the Government of Guam.

B. **Federal Debarment and Suspension (Executive Orders 12549 and 12689).** A contract award (see 2 CFR 180.220) must not be made to parties listed on the government-wide exclusions in the System for Award Management (SAM), in accordance with the OMB guidelines at 2 CFR 180 that implement Executive Orders 12549 (3 CFR part 1986 Comp., p. 189) and 12689 (3 CFR

part 1989 Comp., p. 235), "Debarment and Suspension." SAM Exclusions contains the names of parties debarred, suspended, or otherwise excluded by agencies, as well as parties declared ineligible under statutory or regulatory authority other than Executive Order 12549. As required by Executive Order 12549, Debarment and Suspension, and implemented at 34 CFR Part 85, for prospective participants in primary covered transactions, as defined at 34 CFR Part 85, Sections 85.105 and 85.110. The Contractor certifies that it and its principals: 1) Are not presently debarred, suspended, proposed for debarment, declared ineligible, or voluntarily excluded from covered transactions by any federal department or agency; 2) Have not within a three-year period preceding this application been convicted of or had a civil judgment rendered against them for commission of fraud or a criminal offense in connection with obtaining, attempting to obtain, or performing a public (federal, state, or local) transaction or contract under a public transaction; violation of federal or state antitrust statutes or commission of embezzlement, theft, forgery, bribery, falsification or destruction of records, making false statements, or receiving stolen property; 3) Are not presently indicted for or otherwise criminally or civilly charged by a governmental entity (federal, state, or local) with commission of any of the offenses enumerated above; and 4) Have not within a three-year period preceding this application had one or more public transactions (federal, state, or local) terminated for cause or default. Contractor further warrants that it is not a party listed on the government wide exclusions in the System for Award Management (SAM), and will comply with the provisions of Subpart C of 2 CFR Part 1326, "Nonprocurement Debarment and Suspension," (published in the Federal Register on December 21, 2006, 71 FR 76573) which generally prohibits entities that have been debarred, suspended, or voluntarily excluded from participating in nonprocurement transactions either through primary or lower tier covered transactions, and which sets forth the responsibilities of recipients of federal financial assistance regarding transactions with other persons, including subrecipients and contractors. Contractor will provide a Certification Regarding Debarment, Suspension, Ineligibility, and Voluntary Exclusion, Lower Tier Covered Transaction (Sub-Recipient), which is a material representation of fact. Submission of this certification is a pre-requisite for entering into this Agreement, imposed by Executive Order 12549, 28 CFR Part 67, Section 67.510.

ACCESS TO RECORDS, INSPECTION, AND AUDIT REVIEW

A. **Access to Records.** The Contractor, including its subcontractors, if any, shall maintain all books, documents, papers, accounting records and other evidence pertaining to costs incurred and to make such materials available at their respective office at all reasonable times during the contract period and for three (3) years from the date of final payment under this Formal Agreement, for inspection by the PAG. Each subcontract by the Contractor pursuant to this Agreement shall include a provision containing the conditions of this Section.

B. **Right to Audit.** Contractor shall establish and maintain a reasonable accounting system that enables the PAG to readily identify Contractor's assets, expenses, costs of goods, and use of funds. the PAG and its authorized representatives shall have the right to audit, to examine, and to make copies of or extracts from all financial and related records (in whatever form they may be kept, whether written, electronic, or other) relating to or pertaining to this Agreement kept by or under the control of the Contractor, including, but not limited to those kept by the Contractor, its employees, agents, assigns, successors, and subcontractors. Such records shall include, but not be

limited to, accounting records, written policies and procedures; subcontract files (including proposals of successful and unsuccessful bidders, bid recaps, etc.); all paid vouchers including those for out-of-pocket expenses; other reimbursement supported by invoices; ledgers; cancelled checks; deposit slips; bank statements; journals; original estimates; estimating work sheets; contract amendments and change order files; backcharge logs and supporting documentation; insurance documents; payroll documents; timesheets; memoranda; and correspondence. Contractor shall, at all times during the term of this Agreement and for a period of ten years after the completion of this Agreement, maintain such records, together with such supporting or underlying documents and materials. The Contractor shall at any time requested by the PAG, whether during or after completion of this Agreement, and at Contractor's own expense make such records available for inspection and audit (including copies and extracts of records as required) by the PAG. Such records shall be made available to the PAG during normal business hours at the Contractor's office or place of business and [subject to a three-day written notice/without prior notice]. In the event that no such location is available, then the financial records, together with the supporting or underlying documents and records, shall be made available for audit at a time and location that is convenient for the PAG. Contractor shall ensure the PAG has these rights with Contractor's employees, agents, assigns, successors, and subcontractors, and the obligations of these rights shall be explicitly included in any subcontracts or agreements formed between the Contractor and any subcontractors to the extent that those subcontracts or agreements relate to fulfillment of the Contractor's obligations to the PAG. Costs of any audits conducted under the authority of this right to audit and not addressed elsewhere will be borne by the PAG unless certain exemption criteria are met. If the audit identifies overpricing or overcharges (of any nature) by the Contractor to the PAG in excess of one-half of one percent (.5%) of the total contract billings, the Contractor shall reimburse the PAG for the total costs of the audit. If the audit discovers substantive findings related to fraud, misrepresentation, or non-performance, the PAG may recoup the costs of the audit work from the Contractor. Any adjustments and/or payments that must be made as a result of any such audit or inspection of the Contractor's invoices and/or records shall be made within a reasonable amount of time (not to exceed 90 days) from presentation of the PAG's findings to Contractor.

C. **Right to Enter and Inspect.** the PAG may, at any time, without notice, enter and inspect a Contractor's or subcontractor's facilities, place(s) of business, or any place(s) of performance of this Agreement. the PAG may enter and inspect any plans, supplies, services, equipment, work and records at these locations which are related to the performance of this Agreement, and may conduct any testing deemed necessary to determine whether the Contractor's or subcontractor's compliance or conformity to the solicitation or contract requirements. Guam may enter and audit the cost or pricing data, books, and records of the Contractor or any subcontractor, and/or investigate in connection with an action to debar or suspend a person from consideration for award of contracts pursuant to §9102 (Authority to Debar or Suspend) of the Guam Procurement Rules and Regulations.

FEDERAL REQUIREMENTS

Contractor agrees to comply with all applicable federal law, regulations, and executive orders, all standards, orders, requirements set forth under the federal award that is funding this Agreement, and all policies, procedures, and directives issued by the Federal Awarding Agency.

MODIFICATION

This Agreement may only be amended, modified, or extended in accordance with the applicable federal law, the terms and conditions of the federal award that is funding this Agreement, and the policies and procedures of the Federal Awarding Agency. Deviations from budget, project scope, objective, and/or time of performance require notification to the Federal Awarding Agency, and may require prior approval of the Federal Awarding Agency.

FALSE CLAIMS AND WHISTLEBLOWERS

Contractor acknowledges that 31 U.S.C. Chap. 38 (Administrative Remedies for False Claims and Statements) and Title 5 GCA Chapter 37, the False Claims and Whistleblower Act applies to this Agreement and to all Contractor's actions pertaining to this Agreement. The False Claims and Whistleblower Act was passed as Public Law 34-116, Chapter III, Section 20 (lapsed into law August 24, 2018) and codified at Title 5 GCA Chapter 37.

IMPLEMENTATION OF CLEAN AIR ACT AND FEDERAL WATER POLLUTION CONTROL ACT

(APPLICABLE TO ALL CONTRACTS AND SUBCONTRACTS EXCEEDING \$150,000)

Contractor agrees to comply with all applicable standards, orders, or requirements issued under Section 306 of the Clean Air Act (42 USC, 1857H), Section 508 of the Clean Water Act (33 USC, 1368), Executive Order 11378, and Environmental Protection Agency regulations (40 C.F.R., Part 15), which prohibit the use under nonexempt federal contracts, grants, or loans of facilities included on the EPA list of Violating Facilities. Contractor shall report violations to the PAG and to the USEPA Assistant Administrator for Enforcement (ENO329).

By executing this contract, and any subcontracts, as appropriate, the Contractor and any subcontractors will be deemed to have stipulated as follows:

A. That any person who is or will be utilized in the performance of this contract is not prohibited from receiving an award due to a violation of Section 508 of the Clean Water Act or Section 306 of the Clean Air Act.

B. That the Contractor agrees to include or cause to be included the requirements of paragraph (A) of this Section in every subcontract, and further agrees to take such action as the contracting agency may direct as a means of enforcing such requirements.

□ EQUAL EMPLOYMENT OPPORTUNITY COMPLIANCE
(APPLICABLE TO ALL CONSTRUCTION CONTRACTS AND SUBCONTRACTS)

The Contractor and all subcontractors must comply with the following policies: Executive Order 11246, 41 CFR 60, 29 CFR 1625-1627, Title 23 USC Section 140, the Rehabilitation Act of 1973, as amended (29 USC 794), Title VI of the Civil Rights Act of 1964, as amended, and related regulations including 49 CFR Parts 21, 26 and 27; and 23 CFR Parts 200, 230, and 633.

The Contractor and all subcontractors must also comply with: the requirements of the Equal Opportunity Clause in 41 CFR 60-1.4(b) and, for all construction contracts exceeding \$10,000, the Standard Federal Equal Employment Opportunity Construction Contract Specifications in 41 CFR 60-4.3.

A. Equal Employment Opportunity: Equal employment opportunity (EEO) requirements not to discriminate and to take affirmative action to assure equal opportunity as set forth under laws, executive orders, rules, regulations (28 CFR 35, 29 CFR 1630, 29 CFR 1625-1627, 41 CFR 60 and 49 CFR 27) and orders of the Secretary of Labor as modified by the provisions prescribed herein, and imposed pursuant to 23 U.S.C. 140 shall constitute the EEO and specific affirmative action standards for the Contractor's project activities under this contract. The provisions of the Americans with Disabilities Act of 1990 (42 U.S.C. 12101 et seq.) set forth under 28 CFR 35 and 29 CFR 1630 are incorporated by reference in this contract. In the execution of this contract, the Contractor agrees to comply with the following minimum specific requirement activities of EEO:

1) The Contractor will work with the PAG and the Federal Government to ensure that it has made every good faith effort to provide equal opportunity with respect to all of its terms and conditions of employment and in their review of activities under the contract.

2) The Contractor will accept as its operating policy the following statement:

"It is the policy of this Company to assure that applicants are employed, and that employees are treated during employment, without regard to their race, religion, sex, color, national origin, age or disability. Such action shall include: employment, upgrading, demotion, or transfer; recruitment or recruitment advertising; layoff or termination; rates of pay or other forms of compensation; and selection for training, including apprenticeship, pre-apprenticeship, and/or on-the-job training."

B. EEO Officer: The Contractor will designate and make known to the contracting officers an EEO Officer who will have the responsibility for and must be capable of effectively administering and promoting an active EEO program and who must be assigned adequate authority and responsibility to do so.

C. Dissemination of Policy: All members of the Contractor's staff who are authorized to hire, supervise, promote, and discharge employees, or who recommend such action, or who are substantially involved in such action, will be made fully cognizant of, and will implement, the Contractor's EEO policy and contractual responsibilities to provide EEO in each grade and classification of employment. To ensure that the above agreement will be met, the following actions will be taken as a minimum:

1) Periodic meetings of supervisory and personnel office employees will be conducted before the start of work and then not less often than once every six months, at which time the Contractor's EEO policy and its implementation will be reviewed and explained. The meetings will be conducted by the EEO Officer.

2) All new supervisory or personnel office employees will be given a thorough indoctrination by the EEO Officer, covering all major aspects of the Contractor's EEO obligations within thirty days following their reporting for duty with the Contractor.

3) All personnel who are engaged in direct recruitment for the project will be instructed by the EEO Officer in the Contractor's procedures for locating and hiring minorities and women.

4) Notices and posters setting forth the Contractor's EEO policy will be placed in areas readily accessible to employees, applicants for employment and potential employees.

5) The Contractor's EEO policy and the procedures to implement such policy will be brought to the attention of employees by means of meetings, employee handbooks, or other appropriate means.

D. Recruitment: When advertising for employees, the Contractor will include in all advertisements for employees the notation: "An Equal Opportunity Employer." All such advertisements will be placed in publications having a large circulation among minorities and women in the area from which the project work force would normally be derived.

1) The Contractor will, unless precluded by a valid bargaining agreement, conduct systematic and direct recruitment through public and private employee referral sources likely to yield qualified minorities and women. To meet this requirement, the Contractor will identify sources of potential minority group employees, and establish with such identified sources procedures whereby minority and women applicants may be referred to the Contractor for employment consideration.

2) In the event the Contractor has a valid bargaining agreement providing for exclusive hiring hall referrals, the Contractor is expected to observe the provisions of that agreement to the extent that the system meets the Contractor's compliance with EEO contract provisions. Where implementation of such an agreement has the effect of discriminating against minorities or women, or obligates the Contractor to do the same, such implementation violates Federal nondiscrimination provisions.

3) The Contractor will encourage its present employees to refer minorities and women as applicants for employment. Information and procedures with regard to referring such applicants will be discussed with employees.

E. Personnel Actions: Wages, working conditions, and employee benefits shall be established and administered, and personnel actions of every type, including hiring, upgrading, promotion, transfer, demotion, layoff, and termination, shall be taken without regard to race, color, religion, sex, national origin, age or disability. The following procedures shall be followed:

1) The Contractor will conduct periodic inspections of project sites to insure that working conditions and employee facilities do not indicate discriminatory treatment of project site personnel.

2) The Contractor will periodically evaluate the spread of wages paid within each classification to determine any evidence of discriminatory wage practices.

3) The Contractor will periodically review selected personnel actions in depth to determine whether there is evidence of discrimination. Where evidence is found, the Contractor will promptly take corrective action. If the review indicates that the discrimination may extend beyond the actions reviewed, such corrective action shall include all affected persons.

4) The Contractor will promptly investigate all complaints of alleged discrimination made to the Contractor in connection with its obligations under this Agreement, will attempt to resolve such complaints, and will take appropriate corrective action within a reasonable time. If the investigation indicates that the discrimination may affect persons other than the complainant, such corrective action shall include such other persons. Upon completion of each investigation, the Contractor will inform every complainant of all of their avenues of appeal.

F. Training and Promotion:

1) The Contractor will assist in locating, qualifying, and increasing the skills of minorities and women who are applicants for employment or current employees. Such efforts should be aimed at developing full journey level status employees in the type of trade or job classification involved.

2) Consistent with the Contractor's work force requirements and as permissible under Federal and State regulations, the Contractor shall make full use of training programs, i.e., apprenticeship, and on-the-job training programs for the geographical area of contract performance. In the event a special provision for training is provided under this Agreement, this subparagraph will be superseded as indicated in the special provision. the PAG may reserve training positions for persons who receive welfare assistance in accordance with 23 U.S.C. 140(a).

3) The Contractor will advise employees and applicants for employment of available training programs and entrance requirements for each.

4) The Contractor will periodically review the training and promotion potential of employees who are minorities and women and will encourage eligible employees to apply for such training and promotion.

G. Unions: If the Contractor relies in whole or in part upon unions as a source of employees, the Contractor will use good faith efforts to obtain the cooperation of such unions to increase opportunities for minorities and women. Actions by the Contractor, either directly or through a contractor's association acting as agent, will include the procedures set forth below:

1) The Contractor will use good faith efforts to develop, in cooperation with the unions, joint training programs aimed toward qualifying more minorities and women for membership in the unions and increasing the skills of minorities and women so that they may qualify for higher paying employment.

2) The Contractor will use good faith efforts to incorporate an EEO clause into each union agreement to the end that such union will be contractually bound to refer applicants without regard to their race, color, religion, sex, national origin, age or disability.

3) The Contractor is to obtain information as to the referral practices and policies of the labor union except that to the extent such information is within the exclusive possession of the labor union and such labor union refuses to furnish such information to the Contractor, the

Contractor shall so certify to the PAG and shall set forth what efforts have been made to obtain such information.

4) In the event the union is unable to provide the Contractor with a reasonable flow of referrals within the time limit set forth in the collective bargaining agreement, the Contractor will, through independent recruitment efforts, fill the employment vacancies without regard to race, color, religion, sex, national origin, age or disability; making full efforts to obtain qualified and/or qualifiable minorities and women. The failure of a union to provide sufficient referrals (even though it is obligated to provide exclusive referrals under the terms of a collective bargaining agreement) does not relieve the Contractor from the requirements of this paragraph. In the event the union referral practice prevents the Contractor from meeting the obligations pursuant to Executive Order 11246, as amended, and these special provisions, the Contractor shall immediately notify the PAG.

H. Reasonable Accommodation for Applicants/Employees with Disabilities: The Contractor must be familiar with the requirements for and comply with the Americans with Disabilities Act and all rules and regulations established thereunder. Employers must provide reasonable accommodation in all employment activities unless to do so would cause an undue hardship.

I. Selection of Subcontractors, Procurement of Materials and Leasing of Equipment: The Contractor shall not discriminate on the grounds of race, color, religion, sex, national origin, age or disability in the selection and retention of subcontractors, including procurement of materials and leases of equipment. The Contractor shall take all necessary and reasonable steps to ensure nondiscrimination in the administration of this Agreement.

1) The Contractor shall notify all potential subcontractors and suppliers and lessors of their EEO obligations under this Agreement.

2) The Contractor will use good faith efforts to ensure subcontractor compliance with their EEO obligations.

J. Records and Reports: The Contractor shall keep such records as necessary to document compliance with the EEO requirements. Such records shall be retained for a period of three years following the date of the final payment to the Contractor for all the Work under this Agreement and shall be available at reasonable times and places for inspection by authorized representatives of the PAG.

1) The records kept by the Contractor shall document the following:

(a) The number and work hours of minority and non-minority group members and women employed in each work classification on the project;

(b) The progress and efforts being made in cooperation with unions, when applicable, to increase employment opportunities for minorities and women; and

(c) The progress and efforts being made in locating, hiring, training, qualifying, and upgrading minorities and women;

2) The Contractor and any subcontractors will submit an annual report to the PAG each July for the duration of the Project, indicating the number of minority, women, and non-minority

group employees currently engaged in each work classification required by the Work under this Agreement. The staffing data should represent the project work force on board in all or any part of the last payroll period preceding the end of July. If on-the-job training is being required by special provision, the Contractor will be required to collect and report training data. The employment data should reflect the work force on board during all or any part of the last payroll period preceding the end of July.

NONSEGREGATED FACILITIES
(APPLICABLE TO ALL CONSTRUCTION CONTRACTS AND SUBCONTRACTS)

The Contractor must ensure that facilities provided for employees are provided in such a manner that segregation on the basis of race, color, religion, sex, or national origin cannot result. The Contractor may neither require such segregated use by written or oral policies nor tolerate such use by employee custom. The Contractor's obligation extends further to ensure that its employees are not assigned to perform their services at any location, under the Contractor's control, where the facilities are segregated. The term "facilities" includes waiting rooms, work areas, restaurants and other eating areas, time clocks, restrooms, washrooms, locker rooms, and other storage or dressing areas, parking lots, drinking fountains, recreation or entertainment areas, transportation, and housing provided for employees. The Contractor shall provide separate or single-user restrooms and necessary dressing or sleeping areas to assure privacy between sexes.

DAVIS-BACON ACT COMPLIANCE
(APPLICABLE TO ALL CONSTRUCTION CONTRACTS AND SUBCONTRACTS
EXCEEDING \$2,000)

A. Minimum wages

1) All laborers and mechanics employed or working upon the site of the work, will be paid unconditionally and not less often than once a week, and without subsequent deduction or rebate on any account (except such payroll deductions as are permitted by regulations issued by the Secretary of Labor under the Copeland Act (29 CFR part 3)), the full amount of wages and bona fide fringe benefits (or cash equivalents thereof) due at time of payment computed at rates not less than those contained in the wage determination of the Secretary of Labor which is attached hereto and made a part hereof, regardless of any contractual relationship which may be alleged to exist between the Contractor and such laborers and mechanics.

Contributions made or costs reasonably anticipated for bona fide fringe benefits under section 1(b)(2) of the Davis-Bacon Act on behalf of laborers or mechanics are considered wages paid to such laborers or mechanics, subject to the provisions of paragraph 1.d. of this section; also, regular contributions made or costs incurred for more than a weekly period (but not less often than quarterly) under plans, funds, or programs which cover the particular weekly period, are deemed to be constructively made or incurred during such weekly period. Such laborers and mechanics shall be paid the appropriate wage rate and fringe benefits on the wage determination for the classification of work actually performed, without regard to skill, except as provided in

29 CFR 5.5(a)(4). Laborers or mechanics performing work in more than one classification may be compensated at the rate specified for each classification for the time actually worked therein: Provided, That the employer's payroll records accurately set forth the time spent in each classification in which work is performed. The wage determination (including any additional classification and wage rates conformed under paragraph 1.b. of this section) and the Davis-Bacon poster (WH-1321) shall be posted at all times by the Contractor and its subcontractors at the site of the work in a prominent and accessible place where it can be easily seen by the workers.

2) The contracting officer shall require that any class of laborers or mechanics, including helpers, which is not listed in the wage determination and which is to be employed under the contract shall be classified in conformance with the wage determination. The contracting officer shall approve an additional classification and wage rate and fringe benefits therefore only when the following criteria have been met:

- (i) The work to be performed by the classification requested is not performed by a classification in the wage determination; and
- (ii) The classification is utilized in the area by the construction industry; and
- (iii) The proposed wage rate, including any bona fide fringe benefits, bears a reasonable relationship to the wage rates contained in the wage determination.

3) If the Contractor and the laborers and mechanics to be employed in the classification (if known), or their representatives, and the contracting officer agree on the classification and wage rate (including the amount designated for fringe benefits where appropriate), a report of the action taken shall be sent by the contracting officer to the Administrator of the Wage and Hour Division, Employment Standards Administration, U.S. Department of Labor, Washington, DC 20210. The Administrator, or an authorized representative, will approve, modify, or disapprove every additional classification action within 30 days of receipt and so advise the contracting officer or will notify the contracting officer within the 30-day period that additional time is necessary.

4) In the event the Contractor, the laborers or mechanics to be employed in the classification or their representatives, and the contracting officer do not agree on the proposed classification and wage rate (including the amount designated for fringe benefits, where appropriate), the contracting officer shall refer the questions, including the views of all interested parties and the recommendation of the contracting officer, to the Wage and Hour Administrator for determination. The Wage and Hour Administrator, or an authorized representative, will issue a determination within 30 days of receipt and so advise the contracting officer or will notify the contracting officer within the 30-day period that additional time is necessary.

5) The wage rate (including fringe benefits where appropriate) determined pursuant to paragraphs 1.b.(2) or 1.b.(3) of this section, shall be paid to all workers performing work in the classification under this contract from the first day on which work is performed in the classification.

6) Whenever the minimum wage rate prescribed in the contract for a class of laborers or mechanics includes a fringe benefit which is not expressed as an hourly rate, the Contractor shall either pay the benefit as stated in the wage determination or shall pay another bona fide fringe benefit or an hourly cash equivalent thereof.

7) If the Contractor does not make payments to a trustee or other third person, the Contractor may consider as part of the wages of any laborer or mechanic the amount of any costs reasonably anticipated in providing bona fide fringe benefits under a plan or program, Provided, That the Secretary of Labor has found, upon the written request of the Contractor, that the applicable standards of the Davis-Bacon Act have been met. The Secretary of Labor may require the Contractor to set aside, in a separate account, assets for the meeting of obligations under the plan or program.

B. Withholding

The contracting agency shall upon its own action or upon written request of an authorized representative of the Department of Labor, withhold or cause to be withheld from the Contractor under this contract, or any other Federal contract with the same prime Contractor, or any other federally-assisted contract subject to Davis-Bacon prevailing wage requirements, which is held by the same prime Contractor, so much of the accrued payments or advances as may be considered necessary to pay laborers and mechanics, including apprentices, trainees, and helpers, employed by the Contractor or any subcontractor the full amount of wages required by the contract. In the event of failure to pay any laborer or mechanic, including any apprentice, trainee, or helper, employed or working on the site of the work, all or part of the wages required by the contract, the PAG may, after written notice to the Contractor, take such action as may be necessary to cause the suspension of any further payment, advance, or guarantee of funds until such violations have ceased.

C. Payrolls and Basic Records

1) Payrolls and basic records relating thereto shall be maintained by the Contractor during the course of the work and preserved for a period of three years thereafter for all laborers and mechanics working at the site of the work. Such records shall contain the name, address, and social security number of each such worker, his or her correct classification, hourly rates of wages paid (including rates of contributions or costs anticipated for bona fide fringe benefits or cash equivalents thereof of the types described in section 1(b)(2)(B) of the Davis-Bacon Act), daily and weekly number of hours worked, deductions made and actual wages paid. Whenever the Secretary of Labor has found under 29 CFR 5.5(a)(1)(iv) that the wages of any laborer or mechanic include the amount of any costs reasonably anticipated in providing benefits under a plan or program described in section 1(b)(2)(B) of the Davis-Bacon Act, the Contractor shall maintain records which show that the commitment to provide such benefits is enforceable, that the plan or program is financially responsible, and that the plan or program has been communicated in writing to the laborers or mechanics affected, and records which show the costs anticipated or the actual cost incurred in providing such benefits. Contractors employing apprentices or trainees under approved programs shall maintain written evidence of the

registration of apprenticeship programs and certification of trainee programs, the registration of the apprentices and trainees, and the ratios and wage rates prescribed in the applicable programs.

2) The Contractor shall submit weekly for each week in which any contract work is performed a copy of all payrolls to the PAG. The payrolls submitted shall set out accurately and completely all of the information required to be maintained under 29 CFR 5.5(a)(3)(i), except that full social security numbers and home addresses shall not be included on weekly transmittals. Instead the payrolls shall only need to include an individually identifying number for each employee (e.g., the last four digits of the employee's social security number). The required weekly payroll information may be submitted in any form desired. Optional Form WH-347 is available for this purpose from the Wage and Hour Division Web site at <http://www.dol.gov/esa/whd/forms/wh347instr.htm> or its successor site. The prime Contractor is responsible for the submission of copies of payrolls by all subcontractors. Contractors and subcontractors shall maintain the full social security number and current address of each covered worker, and shall provide them upon request to the PAG for transmission to the Wage and Hour Division of the Department of Labor for purposes of an investigation or audit of compliance with prevailing wage requirements. It is not a violation of this section for a prime contractor to require a subcontractor to provide addresses and social security numbers to the prime contractor for its own records, without weekly submission to the PAG.

3) Each payroll submitted shall be accompanied by a "Statement of Compliance," signed by the Contractor or subcontractor or his or her agent who pays or supervises the payment of the persons employed under the contract and shall certify the following:

(i) That the payroll for the payroll period contains the information required to be provided under §5.5 (a)(3)(ii) of Regulations, 29 CFR part 5, the appropriate information is being maintained under §5.5 (a)(3)(i) of Regulations, 29 CFR part 5, and that such information is correct and complete;

(ii) That each laborer or mechanic (including each helper, apprentice, and trainee) employed on the contract during the payroll period has been paid the full weekly wages earned, without rebate, either directly or indirectly, and that no deductions have been made either directly or indirectly from the full wages earned, other than permissible deductions as set forth in Regulations, 29 CFR part 3;

(iii) That each laborer or mechanic has been paid not less than the applicable wage rates and fringe benefits or cash equivalents for the classification of work performed, as specified in the applicable wage determination incorporated into the contract.

4) The weekly submission of a properly executed certification set forth on the reverse side of Optional Form WH-347 shall satisfy the requirement for submission of the "Statement of Compliance" required by paragraph 3.b.(2) of this section.

5) The falsification of any of the above certifications may subject the Contractor or subcontractor to civil or criminal prosecution under section 1001 of title 18 and section 231 of title 31 of the United States Code.

6) The Contractor or subcontractor shall make the records required under this section available for inspection, copying, or transcription by authorized representatives of the contracting agency or the Department of Labor, and shall permit such representatives to interview employees during working hours on the job. If the Contractor or subcontractor fails to submit the required records or to make them available, the Federal granting agency may, after written notice to the Contractor, or the contracting agency, take such action as may be necessary to cause the suspension of any further payment, advance, or guarantee of funds. Furthermore, failure to submit the required records upon request or to make such records available may be grounds for debarment action pursuant to 29 CFR 5.12.

D. Apprentices and trainees

1) Apprentices (programs of the USDOL).

Apprentices will be permitted to work at less than the predetermined rate for the work they performed when they are employed pursuant to and individually registered in a bona fide apprenticeship program registered with the U.S. Department of Labor, Employment and Training Administration, Office of Apprenticeship Training, Employer and Labor Services, or with a State Apprenticeship Agency recognized by the Office, or if a person is employed in his or her first 90 days of probationary employment as an apprentice in such an apprenticeship program, who is not individually registered in the program, but who has been certified by the Office of Apprenticeship Training, Employer and Labor Services or a State Apprenticeship Agency (where appropriate) to be eligible for probationary employment as an apprentice.

The allowable ratio of apprentices to journeymen on the job site in any craft classification shall not be greater than the ratio permitted to the Contractor as to the entire work force under the registered program. Any worker listed on a payroll at an apprentice wage rate, who is not registered or otherwise employed as stated above, shall be paid not less than the applicable wage rate on the wage determination for the classification of work actually performed. In addition, any apprentice performing work on the job site in excess of the ratio permitted under the registered program shall be paid not less than the applicable wage rate on the wage determination for the work actually performed. Where a contractor is performing construction on a project in a locality other than that in which its program is registered, the ratios and wage rates (expressed in percentages of the journeyman's hourly rate) specified in the Contractor's or subcontractor's registered program shall be observed.

Every apprentice must be paid at not less than the rate specified in the registered program for the apprentice's level of progress, expressed as a percentage of the journeymen hourly rate specified in the applicable wage determination. Apprentices shall be paid fringe benefits in accordance with the provisions of the apprenticeship program. If the apprenticeship program does not specify fringe benefits, apprentices must be paid the full amount of fringe benefits listed on the wage determination for the applicable classification. If the Administrator determines that a different practice prevails for the applicable apprentice classification, fringes shall be paid in accordance with that determination.

In the event the Office of Apprenticeship Training, Employer and Labor Services, or a State Apprenticeship Agency recognized by the Office, withdraws approval of an apprenticeship program, the Contractor will no longer be permitted to utilize apprentices at less than the applicable predetermined rate for the work performed until an acceptable program is approved.

2) Trainees (programs of the USDOL).

Except as provided in 29 CFR 5.16, trainees will not be permitted to work at less than the predetermined rate for the work performed unless they are employed pursuant to and individually registered in a program which has received prior approval, evidenced by formal certification by the U.S. Department of Labor, Employment and Training Administration.

The ratio of trainees to journeymen on the job site shall not be greater than permitted under the plan approved by the Employment and Training Administration.

Every trainee must be paid at not less than the rate specified in the approved program for the trainee's level of progress, expressed as a percentage of the journeyman hourly rate specified in the applicable wage determination. Trainees shall be paid fringe benefits in accordance with the provisions of the trainee program. If the trainee program does not mention fringe benefits, trainees shall be paid the full amount of fringe benefits listed on the wage determination unless the Administrator of the Wage and Hour Division determines that there is an apprenticeship program associated with the corresponding journeyman wage rate on the wage determination which provides for less than full fringe benefits for apprentices. Any employee listed on the payroll at a trainee rate who is not registered and participating in a training plan approved by the Employment and Training Administration shall be paid not less than the applicable wage rate on the wage determination for the classification of work actually performed. In addition, any trainee performing work on the job site in excess of the ratio permitted under the registered program shall be paid not less than the applicable wage rate on the wage determination for the work actually performed.

In the event the Employment and Training Administration withdraws approval of a training program, the Contractor will no longer be permitted to utilize trainees at less than the applicable predetermined rate for the work performed until an acceptable program is approved.

3) Equal employment opportunity. The utilization of apprentices, trainees and journeymen under this part shall be in conformity with the equal employment opportunity requirements of Executive Order 11246, as amended, and 29 CFR part 30.

E. Compliance with Copeland Act requirements. The Contractor shall comply with the requirements of 29 CFR part 3, which are incorporated by reference in this contract.

F. Subcontracts. The Contractor or subcontractor shall insert in any subcontracts the clauses contained in 29 CFR 5.5(a)(1) through (10) and such other clauses as the (write in the name of the Federal agency) may by appropriate instructions require, and also a clause requiring the subcontractors to include these clauses in any lower tier subcontracts. The prime Contractor shall

be responsible for the compliance by any subcontractor or lower tier subcontractor with all the contract clauses in 29 CFR 5.5.

G. Contract termination: debarment. A breach of the contract clauses in 29 CFR 5.5 may be grounds for termination of the contract, and for debarment as a contractor and a subcontractor as provided in 29 CFR 5.12.

H. Compliance with Davis-Bacon and Related Act requirements. All rulings and interpretations of the Davis-Bacon and Related Acts contained in 29 CFR parts 1, 3, and 5 are herein incorporated by reference in this contract.

I. Disputes concerning labor standards. Disputes arising out of the labor standards provisions of this contract shall not be subject to the general disputes clause of this contract. Such disputes shall be resolved in accordance with the procedures of the Department of Labor set forth in 29 CFR parts 5, 6, and 7. Disputes within the meaning of this clause include disputes between the Contractor (or any of its subcontractors) and the PAG, the U.S. Department of Labor, or the employees or their representatives.

J. Certification of eligibility.

1) By entering into this contract, the Contractor certifies that neither it (nor he or she) nor any person or firm who has an interest in the Contractor's firm is a person or firm ineligible to be awarded Government contracts by virtue of section 3(a) of the Davis-Bacon Act or 29 CFR 5.12(a)(1).

2) No part of this contract shall be subcontracted to any person or firm ineligible for award of a Government contract by virtue of section 3(a) of the Davis-Bacon Act or 29 CFR 5.12(a)(1).

3) The penalty for making false statements is prescribed in the U.S. Criminal Code, 18 U.S.C. 1001.

CONTRACT WORK HOURS AND SAFETY STANDARDS ACT
(APPLICABLE TO ALL CONTRACTS AND SUBCONTRACTS EXCEEDING \$100,000
AND INVOLVING EMPLOYMENT OF MECHANICS AND LABORERS)

As used in these paragraphs, the terms laborers and mechanics include watchmen and guards.

A. Overtime requirements. No contractor or subcontractor contracting for any part of the contract Work which may require or involve the employment of laborers or mechanics shall require or permit any such laborer or mechanic in any workweek in which he or she is employed on such work to work in excess of forty hours in such workweek unless such laborer or mechanic receives compensation at a rate not less than one and one-half times the basic rate of pay for all hours worked in excess of forty hours in such workweek.

B. Violation; liability for unpaid wages; liquidated damages. In the event of any violation of this section, the Contractor and any subcontractor responsible therefore shall be liable for the unpaid wages. In addition, such Contractor and subcontractor shall be liable to the United States (in the case of work done under contract for the District of Columbia or a territory, to such District or to such territory), for liquidated damages. Such liquidated damages shall be computed with respect to each individual laborer or mechanic, including watchmen and guards, employed in violation of the clause set forth in this section, in the sum of \$10 for each calendar day on which such individual was required or permitted to work in excess of the standard workweek of forty hours without payment of the overtime wages required by this section.

C. Withholding for unpaid wages and liquidated damages. the PAG shall upon its own action or upon written request of an authorized representative of the Department of Labor withhold or cause to be withheld, from any moneys payable on account of work performed by the Contractor or subcontractor under any such contract or any other Federal contract with the same prime Contractor, or any other federally-assisted contract subject to the Contract Work Hours and Safety Standards Act, which is held by the same prime Contractor, such sums as may be determined to be necessary to satisfy any liabilities of such Contractor or subcontractor for unpaid wages and liquidated damages as provided in the clause set forth in this section.

D. Subcontracts. The Contractor or subcontractor shall insert in any subcontracts the clauses set forth in this section and also a clause requiring the subcontractors to include these clauses in any lower tier subcontracts. The prime Contractor shall be responsible for compliance by any subcontractor or lower tier subcontractor with the clauses set forth in this section.

SAFETY: ACCIDENT PREVENTION
(APPLICABLE TO ALL CONSTRUCTION CONTRACTS AND SUBCONTRACTS
EXCEEDING \$100,000)

A. In the performance of this contract the Contractor shall comply with all applicable Federal, State, and local laws governing safety, health, and sanitation. The Contractor shall provide all safeguards, safety devices and protective equipment and take any other needed actions as it determines, or as the contracting officer may determine, to be reasonably necessary to protect the life and health of employees on the job and the safety of the public and to protect property in connection with the performance of the work covered by the contract.

B. It is a condition of this contract, and shall be made a condition of each subcontract, which the Contractor enters into pursuant to this contract, that the Contractor and any subcontractor shall not permit any employee, in performance of the contract, to work in surroundings or under conditions which are unsanitary, hazardous or dangerous to his/her health or safety, as determined under construction safety and health standards (29 CFR 1926) promulgated by the Secretary of Labor, in accordance with Section 107 of the Contract Work Hours and Safety Standards Act (40 U.S.C. 3704).

C. Pursuant to 29 CFR 1926.3, it is a condition of this contract that the Secretary of Labor or authorized representative thereof, shall have right of entry to any site of contract performance to

inspect or investigate the matter of compliance with the construction safety and health standards and to carry out the duties of the Secretary under Section 107 of the Contract Work Hours and Safety Standards Act (40 U.S.C.3704).

D. Hazardous Materials.

(1) The Contractor is responsible for compliance with any applicable Federal, State, and local laws or requirements regarding hazardous materials. If the Contractor encounters a hazardous material or substance not addressed in this Agreement and if reasonable precautions will be inadequate to prevent foreseeable bodily injury or death to persons resulting from a material or substance, including but not limited to asbestos or polychlorinated biphenyl (PCB), encountered on the site by the Contractor, the Contractor shall, upon recognizing the condition, immediately stop Work in the affected area and report the condition to the PAG and the Project Manager in writing.

(2) The Contractor shall indemnify the PAG for the cost and expense incurred: (1) for remediation of a material or substance the Contractor brings to the site and negligently handles; or (2) where the Contractor fails to perform its obligations, except to the extent that the cost and expense are due to the PAG's fault or negligence.

E. Emergencies. In an emergency affecting safety of persons or property, the Contractor shall act, at the Contractor's discretion, to prevent threatened damage, injury or loss.

DRUG FREE WORKPLACE

A. The Contractor shall, within 30 days after award:

(1) Publish a statement notifying its employees that the unlawful manufacture, distribution, dispensing, possession, or use of a controlled substance is prohibited in the Contractor's workplace and specifying the actions that will be taken against employees for violations of such prohibition;

(2) Establish an ongoing drug-free awareness program to inform such employees about -

(i) The dangers of drug abuse in the workplace;

(ii) The Contractor's policy of maintaining a drug-free workplace;

(iii) Any available drug counseling, rehabilitation, and employee assistance programs; and

(iv) The penalties that may be imposed upon employees for drug abuse violations

occurring in the workplace.

(3) Provide all employees engaged in performance of the contract with a copy of the statement required by paragraph (1) of this clause;

(4) Notify such employees in writing in the statement required by subparagraph (b)(1) of this clause that, as a condition of continued employment on this contract, the employee will -

(i) Abide by the terms of the statement; and

(ii) Notify the employer in writing of the employee's conviction under a criminal drug statute for a violation occurring in the workplace no later than 5 days after such conviction.

(5) Notify the Procurement Officer in writing within 10 days after receiving notice under subdivision (4)(ii) of this clause, from an employee or otherwise receiving actual notice of such conviction. The notice shall include the position title of the employee;

(6) Within 30 days after receiving notice under subdivision (4)(ii) of this clause of a conviction, take one of the following actions with respect to any employee who is convicted of a drug abuse violation occurring in the workplace:

(i) Taking appropriate personnel action against such employee, up to and including termination; or

(ii) Require such employee to satisfactorily participate in a drug abuse assistance or rehabilitation program approved for such purposes by a Federal, State, or local health, law enforcement, or other appropriate agency; and

(7) Make a good faith effort to maintain a drug-free workplace through implementation of paragraphs (1) through (6) of this clause.

B. The Contractor, if an individual, agrees by award of the contract or acceptance of a purchase order, not to engage in the unlawful manufacture, distribution, dispensing, possession, or use of a controlled substance while performing this contract.

C. In addition to other remedies available to the PAG, the Contractor's failure to comply with the requirements of paragraph (B) or (C) of this clause may render the Contractor subject to suspension of contract payments, termination of the contract for default, and suspension or debarment.

RIGHTS TO INVENTIONS MADE UNDER A CONTRACT OR AGREEMENT
(APPLICABLE TO ALL CONTRACTS INVOLVING EXPERIMENTAL,
DEVELOPMENTAL, OR RESEARCH WORK BY A SMALL BUSINESS ENTITY OR NON-
PROFIT ENTITY)

A. The Contractor must comply with all applicable requirements of 37 CFR Part 401, "Rights to Inventions Made by Nonprofit Organizations and Small Business Firms Under Government Grants, Contracts and Cooperative Agreements," and any implementing regulations issued by the OEA. The interpretation of this clause and this Agreement is subject to the definitions located at 37 CFR § 401.14.

B. The Contractor may retain the entire right, title, and interest throughout the world to each subject invention subject to the provisions of this clause and 35 U.S.C. 203. With respect to any subject invention in which the Contractor retains title, the Federal government shall have a nonexclusive, nontransferable, irrevocable, paid-up license to practice or have practiced for or on behalf of the United States the subject invention throughout the world.

C. **Invention Disclosure, Election of Title and Filing of Patent Application by Contractor**

1. The Contractor will disclose each subject invention to the OEA ("Federal Agency") within two months after the inventor discloses it in writing to Contractor personnel responsible for patent matters. The disclosure to the agency shall be in the form of a written report and shall identify the contract under which the invention was made and the inventor(s). It shall be sufficiently complete in technical detail to convey a clear understanding to the extent known at the time of the disclosure, of the nature, purpose, operation, and the physical, chemical, biological or electrical characteristics of the invention. The disclosure shall also identify any publication, on sale or public use of the invention and whether a manuscript describing the invention has been

submitted for publication and, if so, whether it has been accepted for publication at the time of disclosure. In addition, after disclosure to the agency, the Contractor will promptly notify the agency of the acceptance of any manuscript describing the invention for publication or of any on sale or public use planned by the Contractor.

2. The Contractor will elect in writing whether or not to retain title to any such invention by notifying the Federal agency within two years of disclosure to the Federal agency. However, in any case where a patent, a printed publication, public use, sale, or other availability to the public has initiated the one year statutory period wherein valid patent protection can still be obtained in the United States, the period for election of title may be shortened by the agency to a date that is no more than 60 days prior to the end of the statutory period.

3. The Contractor will file its initial patent application on a subject invention to which it elects to retain title within one year after election of title or, if earlier, prior to the end of any statutory period wherein valid patent protection can be obtained in the United States after a publication, on sale, or public use. If the Contractor files a provisional application as its initial patent application, it shall file a non-provisional application within 10 months of the filing of the provisional application. The Contractor will file patent applications in additional countries or international patent offices within either ten months of the first filed patent application or six months from the date permission is granted by the Commissioner of Patents to file foreign patent applications where such filing has been prohibited by a Secrecy Order.

4. For any subject invention with Federal agency and Contractor co-inventors, where the Federal agency employing such co-inventor determines that it would be in the interest of the government, pursuant to 35 U.S.C. 207(a)(3), to file an initial patent application on the subject invention, the Federal agency employing such co-inventor, at its discretion and in consultation with the Contractor, may file such application at its own expense, provided that the Contractor retains the ability to elect title pursuant to 35 U.S.C. 202(a).

5. Requests for extension of the time for disclosure, election, and filing under paragraphs (1), (2), and (3) of this clause may, at the discretion of the Federal agency, be granted. When a Contractor has requested an extension for filing a non-provisional application after filing a provisional application, a one-year extension will be granted unless the Federal agency notifies the Contractor within 60 days of receiving the request.

D. Conditions When the Government May Obtain Title

The Contractor will convey to the Federal agency, upon written request, title to any subject invention:

1. If the Contractor fails to disclose or elect title to the subject invention within the times specified in paragraph (C) of this clause, or elects not to retain title.

2. In those countries in which the Contractor fails to file patent applications within the times specified in paragraph (C) of this clause; provided, however, that if the Contractor has filed a patent application in a country after the times specified in paragraph (C) of this clause, but prior to its receipt of the written request of the Federal agency, the Contractor shall continue to retain title in that country.

3. In any country in which the Contractor decides not to continue the prosecution of any non-provisional patent application for, to pay a maintenance, annuity or renewal fee on, or to defend in a reexamination or opposition proceeding on, a patent on a subject invention.

E. Minimum Rights to Contractor and Protection of the Contractor Right to File

1. The Contractor will retain a nonexclusive royalty-free license throughout the world in each subject invention to which the Government obtains title, except if the Contractor fails to disclose the invention within the times specified in (C), above. The Contractor's license extends to its domestic subsidiary and affiliates, if any, within the corporate structure of which the Contractor is a party and includes the right to grant sublicenses of the same scope to the extent the Contractor was legally obligated to do so at the time the contract was awarded. The license is transferable only with the approval of the Federal agency except when transferred to the successor of that party of the Contractor's business to which the invention pertains.

2. The Contractor's domestic license may be revoked or modified by the funding Federal agency to the extent necessary to achieve expeditious practical application of the subject invention pursuant to an application for an exclusive license submitted in accordance with applicable provisions at 37 CFR part 404 and agency licensing regulations (if any). This license will not be revoked in that field of use or the geographical areas in which the Contractor has achieved practical application and continues to make the benefits of the invention reasonably accessible to the public. The license in any foreign country may be revoked or modified at the discretion of the funding Federal agency to the extent the Contractor, its licensees, or the domestic subsidiaries or affiliates have failed to achieve practical application in that foreign country.

3. Before revocation or modification of the license, the funding Federal agency will furnish the Contractor a written notice of its intention to revoke or modify the license, and the Contractor will be allowed thirty days (or such other time as may be authorized by the funding Federal agency for good cause shown by the Contractor) after the notice to show cause why the license should not be revoked or modified. The Contractor has the right to appeal, in accordance with applicable regulations in 37 CFR part 404 and agency regulations (if any) concerning the licensing of Government-owned inventions, any decision concerning the revocation or modification of the license.

F. Contractor Action to Protect the Government's Interest

1. The Contractor agrees to execute or to have executed and promptly deliver to the Federal agency all instruments necessary to: (i) establish or confirm the rights the Government has throughout the world in those subject inventions to which the Contractor elects to retain title; and (ii) convey title to the Federal agency when requested under paragraph (D) above and to enable the government to obtain patent protection throughout the world in that subject invention.

2. The Contractor agrees to require, by written agreement, its employees, other than clerical and nontechnical employees, to disclose promptly in writing to personnel identified as responsible for the administration of patent matters and in a format suggested by the Contractor each subject invention made under contract in order that the Contractor can comply with the disclosure provisions of paragraph (C) of this clause, to assign to the Contractor the entire right, title and interest in and to each subject invention made under contract, and to execute all papers necessary to file patent applications on subject inventions and to establish the government's rights in the subject inventions. This disclosure format should require, as a minimum, the information required by paragraph (C)(1) of this clause. The Contractor shall instruct such employees through employee agreements or other suitable educational programs on the importance of reporting inventions in sufficient time to permit the filing of patent applications prior to U.S. or foreign statutory bars.

3. For each subject invention, the Contractor will, no less than 60 days prior to the expiration of the statutory deadline, notify the Federal agency of any decision: Not to continue the

prosecution of a non-provisional patent application; not to pay a maintenance, annuity or renewal fee; not to defend in a reexamination or opposition proceeding on a patent, in any country; to request, be a party to, or take action in a trial proceeding before the Patent Trial and Appeals Board of the U.S. Patent and Trademark Office, including but not limited to post-grant review, review of a business method patent, *inter partes* review, and derivation proceeding; or to request, be a party to, or take action in a non-trial submission of art or information at the U.S. Patent and Trademark Office, including but not limited to a pre-issuance submission, a post-issuance submission, and supplemental examination.

4. The Contractor agrees to include, within the specification of any United States patent applications and any patent issuing thereon covering a subject invention, the following statement, "This invention was made with government support under the Agreement for Professional Technical Advisory Services between Contractor and OOG, awarded by the OOG under Federal Award Number HQ0005171035. The government has certain rights in the invention."

G. Subcontracts

1. The Contractor will include this clause, suitably modified to identify the parties, in all subcontracts, regardless of tier, for experimental, developmental or research work to be performed by a subcontractor. The subcontractor will retain all rights provided for the Contractor in this clause, and the Contractor will not, as part of the consideration for awarding the subcontract, obtain rights in the subcontractor's subject inventions.

2. The Contractor will include in all other subcontracts, regardless of tier, for experimental developmental or research work the patent rights clause required by the FAR or the Terms and Conditions of Federal Award Number HQ0005171035.

3. In the case of subcontracts, at any tier, when the prime award with the Federal agency was a contract (but not a grant or cooperative agreement), the OEA, subcontractor, and the Contractor agree that the mutual obligations of the parties created by this clause constitute a contract between the subcontractor and the Federal agency with respect to the matters covered by the clause; provided, however, that nothing in this paragraph is intended to confer any jurisdiction under the Contract Disputes Act in connection with proceedings under paragraph (J) of this clause.

H. Reporting on Utilization of Subject Inventions

The Contractor agrees to submit on request periodic reports no more frequently than annually on the utilization of a subject invention or on efforts at obtaining such utilization that are being made by the Contractor or its licensees or assignees. Such reports shall include information regarding the status of development, date of first commercial sale or use, gross royalties received by the Contractor, and such other data and information as the agency may reasonably specify. The Contractor also agrees to provide additional reports as may be requested by the agency in connection with any march-in proceeding undertaken by the agency in accordance with paragraph (J) of this clause. As required by 35 U.S.C. 202(c)(5), the agency agrees it will not disclose such information to persons outside the government without permission of the Contractor.

I. Preference for United States Industry

Notwithstanding any other provision of this clause, the Contractor agrees that neither it nor any assignee will grant to any person the exclusive right to use or sell any subject inventions in the United States unless such person agrees that any products embodying the subject invention or produced through the use of the subject invention will be manufactured substantially in the United

States. However, in individual cases, the requirement for such an agreement may be waived by the Federal agency upon a showing by the Contractor or its assignee that reasonable but unsuccessful efforts have been made to grant licenses on similar terms to potential licensees that would be likely to manufacture substantially in the United States or that under the circumstances domestic manufacture is not commercially feasible.

J. March-in Rights

The Contractor agrees that with respect to any subject invention in which it has acquired title, the Federal agency has the right in accordance with the procedures in 37 CFR 401.6 and any supplemental regulations of the agency to require the Contractor, an assignee or exclusive licensee of a subject invention to grant a nonexclusive, partially exclusive, or exclusive license in any field of use to a responsible applicant or applicants, upon terms that are reasonable under the circumstances, and if the Contractor, assignee, or exclusive licensee refuses such a request the Federal agency has the right to grant such a license itself if the Federal agency determines that:

1. Such action is necessary because the Contractor or assignee has not taken, or is not expected to take within a reasonable time, effective steps to achieve practical application of the subject invention in such field of use.

2. Such action is necessary to alleviate health or safety needs which are not reasonably satisfied by the Contractor, assignee or their licensees;

3. Such action is necessary to meet requirements for public use specified by Federal regulations and such requirements are not reasonably satisfied by the Contractor, assignee or licensees; or

4. Such action is necessary because the agreement required by paragraph (I) of this clause has not been obtained or waived or because a licensee of the exclusive right to use or sell any subject invention in the United States is in breach of such agreement.

INVITATION FOR BID

ISSUING OFFICE:
PORT AUTHORITY OF GUAM
GOVERNMENT OF GUAM
1026 CABRAS HIGHWAY, SUITE 201,
PITI, GUAM 96915

RORY J. RESPICIO
GENERAL MANAGER

DATE ISSUED: 4/23/2024

BID INVITATION NO: IFB/PAG-013-24

BID FOR: **Re-bid 180' Telescopic Boom Lift**

SPECIFICATION: **SEE BELOW**

DESTINATION: **PORT AUTHORITY OF GUAM**

REQUIRED DELIVERY DATE: (460 days ARO) upon receipt of purchase order. Delivery schedule time and quantity will be coordinated between the successful bidder and the requesting department in accordance with the schedules contained in MARAD FY2022 American Marine Highway (AMH) Grant No. 693JF72340007, and in accordance with the expiration date of this grant, currently set to expire on May 1, 2026. This project is funded by the MARAD FY2022 American Marine Highway (AMH) Grant No.: 693JF72340007.

INSTRUCTION TO BIDDERS:

INDICATE WHETHER: INDIVIDUAL PARTNERSHIP CORPORATION

INCORPORATED IN: Florida

This bid shall be submitted in duplicate with electronic copy (pdf format) and sealed to the issuing office above no later than (Time) **2:00 PM** Date: **WEDNESDAY, May 8, 2024** and shall be publicly opened. Alternatively, bids may be submitted via e-mail prior to the due date and time above; please refer to the instructions below. Any bid submitted after the time and date specified above shall be rejected. See attached General Terms and Conditions, and Sealed Bid Solicitation for details.

The undersigned offers and agrees to furnish within the time specified, the articles and services at the price stated opposite the respective items listed on the schedule provided, unless otherwise specified by the bidder. In consideration to the expense of the Government in opening, tabulating, and evaluating this and other bids, and other considerations, the undersigned agrees that this bid remain firm and irrevocable within **90** calendar days from the date opening to supply any or all the items which prices are quoted.

NAME AND ADDRESS OF BIDDER:

Federal Contracts Corp
12918 N. Nebraska Ave
Tampa, FL 33612

SIGNATURE AND TITLE OF PERSON AUTHORIZED TO SIGN THIS BID:



AWARD: CONTRACT NO.: 09-03P-113DA AMOUNT: \$517,205.41 DATE: 05/07/2024

ITEM NO(S). 1.1 AWARDED: \$517,205.41

Telescopic Boom Lift, 180' Reach, Fulltime 4WD

NAME AND ADDRESS OF CONTRACTOR:

Federal Contracts Corp
12918 N. Nebraska Ave, Tampa, FL 33612

CONTRACTING OFFICER:

RORY J. RESPICIO
General Manager

SIGNATURE AND TITLE OF PERSON AUTHORIZED TO SIGN THIS CONTRACT:

Name: Pete Pearson
Title: Vice President

Date: 4/26/24

Date: 05/07/2024

SPECIAL PROVISIONS

Contract Period:

The term of this contract will continue until the expiration of the grant funds under MARAD FY2022 American Marine Highway (AMH) Grant No.: 693JF72340007 and may be extended if the period of performance for the grant funds is extended in accordance with the federal award terms and conditions. The current expiration date of the grant funds is May 1, 2026.

The initial purchase of one (1) Re-bid 180' Telescopic Boom Lift is funded by MARAD FY2022 American Marine Highway (AMH) Grant No. 693JF72340007

Contract incorporates all applicable provision of the Port Authority of Guam Federal Contract Supplement.



PORT OF GUAM
AFURIDAT / PUEYTON GUAHAN
 Jose D. Leon Guerrero Commercial Port
 1026 Cabras Highway, Suite 201, Piti, Guam 96925
 Telephone: 671-477-5931/35 Facsimile: 671-477-2689/4445
 Website: www.portguam.com



Lourdes A. Leon Guerrero
 Governor of Guam
 Joshua F. Tenorio
 Lieutenant Governor

Accountability * Impartiality * Competence * Openness * Value

INVITATION FOR BID NO.: IFB-PAG-013-24

DESCRIPTION:

Re-bid 180' Telescopic Boom Lift

SPECIAL REMINDER TO PROSPECTIVE BIDDERS

Bidders are reminded to read the Sealed Bid Solicitation and Instructions, and General Terms and Conditions attached to the IFB to ascertain that all of the following requirements checked below are submitted in the bid envelope. If hard copies are submitted, One (1) original, one (1) copy, and one (1) CD or USB containing electronic file copy (in PDF format) of the complete bid proposal shall be enclosed in a sealed package or envelope at the date and time for bid opening; or bid may be submitted electronically via e-mail before the deadline, see instructions below. No award will be made until bid security is confirmed.

- BID GUARANTEE (15% of Bid Amount) May be in the form of;**
Reference #11 on the General Terms and Conditions
 - a. Cashier's Check or Certified Check
 - b. Letter of Credit
 - c. Surety Bond – Valid only if accompanied by:
 - 1. Current Certificate of Authority issued by the Insurance Commissioner;
 - 2. Power of Attorney issued by the Surety to the Resident General Agent;
 - 3. Power of Attorney issued by two (2) major officers of the Surety to whoever is signing on their behalf.
- BROCHURES/DESCRIPTIVE LITERATURE;**
- AFFIDAVIT DISCLOSING OWNERSHIP and COMMISSION**
 - a. Date of signature of the person authorized to sign the bid and the notary date must be the same.
- OTHER REQUIREMENTS:**
Disclosure of Shareholder & Commission, Non-Collusion Declaration, D.O.L. Wage Determination Declaration, Restriction against Sexual Offenders Declaration, No Kickbacks or Gratuities Declaration and Ethical Standards Declaration, and Declaration re Contingent Fees, Conflict of Interest Form, SF-LLL Byrd Anti-Lobbying, and Current Business License at the time of the award.

This reminder must be signed and returned in the bid envelope together with the bid. Failure to comply with the above requirements may be cause for disqualification and rejection of the bid.

On this _____ day of _____, 2024, I, _____

authorized representative of _____ acknowledge receipt of this special reminder to prospective bidders with the above referenced IFB.

 Bidder Representative's Signature

INVITATION FOR BID NO.: IFB-PAG-013-24

Re-bid 180' Telescopic Boom Lift

ACKNOWLEDGEMENT RECEIPT FORM

Please be advised that to be considered a prospective bidder you must fill out this Acknowledgement receipt form. Please submit by fax form to (671) 472-1439 or email to macabrera@portofguam.com, and pagprocurement@portofguam.com

Acknowledgement Receipt Form must be submitted no later than three (3) days upon receipt of IFB package.

Name	<u>Pete Pearson</u>
Signature	<u></u>
Date	<u>05/07/2024</u>
Time	<u>9:00am EST</u>
Contact Number	<u>813-631-0000</u>
Fax Number	<u>813-631-0008</u>
Contact Person regarding IFB	<u>Pete Pearson</u>
Title	<u>Vice President</u>
E-Mail Address	<u>pete@federalcontractscorp.com</u>
Company/Firm	<u>Federal Contracts Corp</u>
Address	<u>12918 N. Nebraska Ave, Tampa, FL 33612</u>

Note: IFB recommends that prospective bidders register current contact information with IFB to ensure they receive any notices regarding any changes or update to the IFB. The procuring agency and IFB will not be liable for failure to provide notice to any party who did not register current contact information.

All questions and concerns in regards to this bid must be submitted to the PORT AUTHORITY OF GUAM via fax or email, addressed to the GENERAL MANAGER no later than Wednesday, May 1, 2024 by the close of business at 5:00pm. Your inquiry may be sent by fax to (671)472-1439, or emailed to rirespicio@portofguam.com and copied to pagprocurement@portofguam.com, aisablan@portofguam.com, and macabrera@portofguam.com.

No Entitlement to Preparation Costs – the bidder expressly waives any right it may have against the government for any expenses incurred in connection with the preparation of its bid.

GOVERNMENT OF GUAM

THE PORT AUTHORITY OF GUAM
1026 Cabras Highway, Suite 201
Pki, Guam 96915

BID BOND

NO. _____

KNOW ALL MEN BY THESE PRESENTS that _____, as Principal hereinafter called the Principal, and (Bonding Company), _____ A duly admitted Insurer under the laws of the Territory of Guam, as Surety, hereinafter called the Surety are Held firmly bound unto the Territory of Guam for the sum of _____ Dollars (\$ _____), for Payment of which sum will and truly to be made, the said Principal and the said Surety bind ourselves, our heirs, executors, administrators, successors and assigns, jointly and severally, firmly by these presents.

WHEREAS, the Principal has submitted a bid for (Identify project by number and brief description)

NOW, THEREFORE, if the Territory of Guam shall accept the bid of the Principal and the Principal shall enter into a Contract with the Territory of Guam in accordance with the terms of such bid, and give such bond or bonds as may be specified in bidding or Contract Documents with good and sufficient surety for the faithful performance of such Contract and for the prompt payment of labor and material furnished in the prosecution thereof, or in the event of the failure of the Principal to enter such Contract and give such bond or bonds, if the Principal shall pay to the Territory of Guam the difference not to exceed the penalty hereof between the amounts specified in said bid and such larger amount for which the Territory of Guam may in good faith contract with another party to perform work covered by said bid or an appropriate liquidated amount as specified in the Invitation for Bids then this obligation shall be null and void, otherwise to remain full force and effect.

Signed and sealed this _____ day of _____ 2024

(PRINCIPAL)

(SEAL)

(WITNESS)

(TITLE)

(MAJOR OFFICER OF SURETY)

(TITLE)

(MAJOR OFFICER OF SURETY)

(TITLE)

(RESIDENT GENERAL AGENT)

INSTRUCTION TO PROVIDERS:

NOTICE to all Insurance and Bonding Institutions:

The Bond requires the signatures of the Vendor, two (2) major Officers of the Surety and Resident General Agent, if the Surety is a foreign or alien surety.

When the form is submitted to THE PORT AUTHORITY OF GUAM, it should be accompanied with copies of

The following:

- 1. Current Certificate of Authority to do business on Guam issued by the Department of Revenue and Taxation.**
- 2. Power of Attorney issued by the Surety to the Resident General Agent.**
- 3. Power of Attorney issued by two (2) major officers of the Surety to whoever is signing on their behalf.**

Bonds, submitted as Bid Guarantee, without signatures and supporting documents are invalid and Bids will be rejected.

DECLARATION RE: ETHICAL STANDARDS
(AG Form 005)

Pete Pierson

[state name of declarant signing below], hereby declares that:

The declarant is Federal Contracts Corp [state one of the following: the Bidder/Offeror, a partner of the Bidder/Offeror, an officer of the Bidder/Offeror] making the foregoing identified bid or proposal. To the best of declarant's knowledge, neither declarant nor any officers, representatives, agents, subcontractors or employees of offeror have knowingly influenced any government of Guam employee to breach any of the ethical standards set forth in 5 GCA Chapter 5, Article 11. Further, declarant promises that neither he or she, nor any officer, representative, agent, subcontractor, or employee of bidder/offeror will knowingly influence any government of Guam employee to breach any ethical standards set forth in 5 GCA Chapter 5, Article 11. These statements are made pursuant to 5GCA §§ 5626, 5628 through 5633; and 2 GAR Division 4 § 11103(b).

I hereby declare under penalty of perjury under the laws of Guam that the foregoing is true and correct.



Signature of one of the following:

Bidder/ Offeror, if the bidder/offeror is an individual; Partner, if the bidder/offeror is a partnership; Officer, if the bidder/offeror is a corporation.

DECLARATION RE: NO GRATUITIES or KICKBACKS
(AG Form 004)

Pete Pearson (state name of declarant signing below), hereby declare that:

1. The name of the offering firm or individual is Federal Contracts Corp [state name of bidder/offeror company] Declarant is bidder/offeror [state one of the following: the bidder/offeror, a partner of the bidder/offeror, an officer of the bidder/offeror] making the foregoing identified bid or proposal.

2. To the best of declarant's knowledge, neither declarant, nor any of the bidder's/offeror's officers, representatives, agents, subcontractors, or employees have violated, are violating the prohibition against gratuities and kickbacks set forth in 2 GAR Division 4 § 11107(e). Further, affiant promises, on behalf of bidder/offeror, not to violate the prohibition against gratuities and kickbacks as set forth in 2 GAR Division 4 § 11107(e).

3. To the best of declarant's knowledge, neither declarant, nor any of the bidders/offerors officers, representatives, agents, subcontractors, or employees have offered, given or agreed to give, any government of Guam employee or former government employee, any payment, gift, kickback, gratuity or offer of employment in connection with the bidders/offerors bid or proposal.

4. I make these statements on behalf of myself as a representative of the bidder/offeror, and on behalf of the bidder/offeror's officers, representatives, agents, subcontractors, and employees.

I hereby declare under penalty of perjury under the laws of Guam that the foregoing is true and correct.

Signature of one of the following:

Offeror, if the bidder/offeror is an individual;
Partner, if the bidder/offeror is a partnership;
Officer, if the bidder/offeror is a corporation.

SPECIAL PROVISIONS

RESTRICTION AGAINST SEX OFFENDERS EMPLOYED BY SERVICES PROVIDERS TO GOVERNMENT OF GUAM FROM WORKING ON GOVERNMENT PROPERTY

If a contract for services is awarded to the bidder or offeror, then the service provider must warranty that no person in its employment who has been convicted of a sex offense under the provisions of chapter 25 of Title 9 of Guam code Annotated or of an offense defined in Article 2 of chapter 28 of Title 9 of the Guam Code annotated, or who has been convicted in any other jurisdiction of an offense with the same elements as heretofore defined, or who is listed on the Sex Offender Registry, shall provide services on behalf of the service provider while on government of Guam property, with the exception of public highways. If any employee of a service provider is providing services on government property and is convicted subsequent to an award of a contract, then the service provider warrants that it will notify the Government of the conviction within twenty-four (24) hours of the conviction, and will immediately remove such convicted person from providing services on government property. If the service provider is found to be in violation of any of the provisions of this paragraph, then the government will give notice to the service provider to take corrective action. The service provider shall take corrective action within twenty-four (24) hours of notice from the Government, and the service provider shall notify the Government when action has been taken. If the service providers fail to take corrective steps within twenty-four (24) hours of notice from the Government, then the Government in its sole discretion may suspend temporarily and contract for services until corrective action has been taken.

Signature of Bidder

5/7/2024
Date

Proposer, if an individual;
Partner, if a partnership;
Officer, if a corporation.

DECLARATION RE COMPLIANCE WITH U.S. D.O.L WAGE DETERMINATION

Procurement No: IFB-PAG-013-24 Re-bid 180 FT. Telescopic Boom Lift

Name of Offeror Company: Federal Contracte Corp hereby certifies under penalty of perjury:

(1) That I am Pete Pearson (the offeror, a partner of the offeror, an officer of the offeror) making the bid or proposal in the foregoing identified procurement;

(2) That I have read and understand the provisions of 5 GCA § 5801 and § 5802 which read:

§ 5801. Wage Determination Established.

In such cases where the government of Guam enters into contractual arrangements with a sole proprietorship, a partnership or a corporation ("contractor") for the provision of a service to the government of Guam, and in such cases where the contractor employs a person(s) whose purpose, in whole or in part, is the direct delivery of service contracted by the government of Guam, then the contractor shall pay such employee(s) in accordance with the Wage Determination for Guam and the Northern Mariana Islands issued and promulgated by the U.S. Department of Labor for such labor as is employed in the direct delivery of contract deliverables to the government of Guam.

The Wage Determination most recently issued by the U.S. Department of Labor at the time a contract is awarded to a contractor by the government of Guam shall be used to determine wages, which shall be paid to employees pursuant to this Article. Should any contract contain a renewal clause, then at the time of renewal adjustments, there shall be made stipulations contained in that contract for applying the Wage Determination, as required by this Article, so that the Wage Determination promulgated by the U.S. Department of Labor on a date most recent to the renewal date shall apply.

§ 5802. Benefits.

In addition to the Wage Determination detailed in this Article, any contract to which this Article applies shall also contain provisions mandating health and similar benefits for employees covered by this Article, such benefits having a minimum value as detailed in the Wage Determination issued and promulgated by the U.S. Department of Labor, and shall contain provisions guaranteeing a minimum of ten (10) paid holidays per annum per employee.

(3) That the offeror is in full compliance with 5 GCA § 5801 and § 5802, as may be applicable to the procurement referenced herein;

(4) That I have attached the most recent wage determination applicable to Guam issued by the U.S. Department of Labor. (INSTRUCTIONS – Please attach)

Pete Pearson 05/07/2024
Signature Date

*REGISTER OF WAGE DETERMINATIONS
UNDER THE SERVICE CONTRACT ACT
by direction of the Secretary of Labor

Daniel W. Simms, Division of
Director Wage Determinations

U.S. DEPARTMENT OF LABOR
EMPLOYMENT STANDARDS ADMINISTRATION
WAGE AND HOUR DIVISION
WASHINGTON D.C. 20219
Wage Determination No.: 2015-5693
Revision No.: 19 | Date of Last Revision: 07/17/2023

Note: Contracts subject to the Service Contract Act are generally required to pay at least the applicable minimum wage rate required under Executive Order 14026. If the contract is entered into on or after January 30 2022 or the contract is renewed or extended (e.g., an option is exercised) on or after January 30 2022: The contractor must pay all covered workers at least \$16.20 per hour (or the applicable wage rate listed on this wage determination if it is higher) for all hours spent performing on the contract in 2023.

The applicable Executive Order minimum wage rate will be adjusted annually. Additional information on contractor requirements and worker protections under the Executive Orders is available at <http://www.dol.gov/agencies/whd/government-contracts>.

States: Guam Northern Marianas Wake Island
Area: Guam Statewide
Northern Marianas Statewide
Wake Island Statewide

Fringe Benefits Required Follow the Occupational Listing

OCCUPATION CODE - TITLE	FOOTNOTE RATE	OCCUPATION CODE - TITLE	FOOTNOTE RATE
-------------------------	---------------	-------------------------	---------------

01000 - Administrative Support And Clerical Occupations		
01011 - Accounting Clerk I		14.27***
01012 - Accounting Clerk II		15.02***
01013 - Accounting Clerk III		17.93
01020 - Administrative Assistant		21.43
01025 - Court Reporter		17.40
01041 - Customer Service Representative I		12.75***
01042 - Customer Service Representative II		14.23***
01043 - Customer Service Representative III		15.63***
01051 - Data Entry Operator I		12.16***
01052 - Data Entry Operator II		13.77***
01060 - Dispatcher, Motor Vehicle		17.39
01070 - Document Preparation Clerk		13.65***
01090 - Duplicating Machine Operator		13.85***
01111 - General Clerk I		11.33***
01112 - General Clerk II		12.36***
01113 - General Clerk III		13.48***
01120 - Housing Referral Assistant		19.19
01141 - Messenger Courier		13.37***
01191 - Order Clerk I		12.57***
01192 - Order Clerk II		13.71***
01261 - Personnel Assistant (Employment) I		15.95***
01262 - Personnel Assistant (Employment) II		17.85
01263 - Personnel Assistant (Employment) III		19.89
01270 - Production Control Clerk		22.97
01290 - Rental Clerk		11.10***
01300 - Scheduler, Maintenance		15.53***
01311 - Secretary I		15.55***
01312 - Secretary II		17.40
01313 - Secretary III		19.39
01320 - Service Order Dispatcher		15.40***
01410 - Supply Technician		21.43
01420 - Survey Worker		16.96
01460 - Switchboard Operator/Receptionist		10.78***
01531 - Travel Clerk I		13.01***
01532 - Travel Clerk II		14.13***
01533 - Travel Clerk III		15.09***
01611 - Word Processor I		14.53***
01613 - Word Processor III		18.26
05000 - Automotive Service Occupations		
05005 - Automobile Body Repairer, Fiberglass		17.20
05010 - Automotive Electrician		16.16***
05040 - Automotive Glass Installer		13.31***
05070 - Automotive Worker		15.31***
05110 - Mobile Equipment Servicer		12.95***
05130 - Motor Equipment Metal Mechanic		17.20
05160 - Motor Equipment Metal Worker		15.11***
05190 - Motor Vehicle Mechanic		17.20
05220 - Motor Vehicle Mechanic Helper		11.87***
05250 - Motor Vehicle Upholstery Worker		14.06***
05280 - Motor Vehicle Wrecker		15.11***
05310 - Painter, Automotive		16.16***
05340 - Radiator Repair Specialist		18.13***
05370 - Tire Repairer		12.67***
05400 - Transmission Repair Specialist		17.20
07000 - Food Preparation And Service Occupations		
07010 - Baker		11.10***
07041 - Cook I		14.44***
07042 - Cook II		16.84
07070 - Dishwasher		9.69***
07130 - Food Service Worker		10.11***
07210 - Meat Cutter		13.34***
07260 - Waiter/Waitress		9.73***

09000 - Furniture Maintenance And Repair Occupations		
09010 - Electrostatic Spray Painter		18.75
09040 - Furniture Handler		11.37***
09080 - Furniture Refinisher		18.75
09090 - Furniture Refinisher Helper		13.77***
09110 - Furniture Repairer, Mi		16.32
09130 - Upholsterer		18.75
11000 - General Services And Support Occupations		
11090 - Cleaner, Vehicles		9.69***
11090 - Elevator Operator		9.69***
11090 - Gardener		14.28***
11123 - Housekeeping Aide		10.13***
11150 - Janitor		10.13***
11210 - Laborer, Grounds Maintenance		10.79***
11240 - Maid or Houseman		9.67***
11260 - Pruner		9.66***
11270 - Tractor Operator		13.07***
11330 - Trail Maintenance Worker		10.79***
01612 - Word Processor II		16.51
11360 - Window Cleaner		11.32***
12000 - Health Occupations		
12010 - Ambulance Driver		18.96
12011 - Breath Alcohol Technician		18.96
12012 - Certified Occupational Therapist Assistant		26.02
12015 - Certified Physical Therapist Assistant		26.02
12020 - Dental Assistant		18.79
12025 - Dental Hygienist		39.79
12030 - EKG Technician		28.73
12035 - Electroneurodiagnostic Technologist		28.73
12040 - Emergency Medical Technician		18.96
12071 - Licensed Practical Nurse I		16.95
12072 - Licensed Practical Nurse II		18.96
12079 - Licensed Practical Nurse III		21.34
12100 - Medical Assistant		13.42***
12110 - Medical Laboratory Technician		18.82
12160 - Medical Record Clerk		14.87***
12180 - Medical Record Technician		17.77
12195 - Medical Transcriptionist		14.95
12210 - Nuclear Medicine Technologist		41.68
12221 - Nursing Assistant I		12.43***
12222 - Nursing Assistant II		13.97***
12223 - Nursing Assistant III		15.24***
12224 - Nursing Assistant IV		17.12
12235 - Optical Dispenser		18.96
12236 - Optical Technician		14.95
12250 - Pharmacy Technician		15.49***
12260 - Prosthetist		18.95
12305 - Radiologic Technologist		20.73
12311 - Registered Nurse I		23.50
12312 - Registered Nurse II		28.73
12313 - Registered Nurse III, Specialist		28.73
12314 - Registered Nurse III		34.76
12315 - Registered Nurse III, Anesthetist		34.76
12316 - Registered Nurse IV		41.68
12317 - Scheduler (Drug and Alcohol Testing)		23.50
12320 - Substance Abuse Treatment Counselor		23.90
13000 - Information And Arts Occupations		
13011 - Exhibits Specialist I		21.42
13012 - Exhibits Specialist II		26.53
13013 - Exhibits Specialist III		32.45
13041 - Illustrator I		21.42
13042 - Illustrator II		26.53
13043 - Illustrator III		32.45

OCCUPATION CODE - TITLE	FOOTNOTE RATE	FOOTNOTE
13047 - Librarian	28.38	
13050 - Library Aide/Clerk	17.05	
13054 - Library Information Technology Systems Administrator	26.53	
13058 - Library Technician	18.11	
13061 - Media Specialist I	19.15	
13062 - Media Specialist II	21.42	
13063 - Media Specialist III	23.87	
13071 - Photographer I	19.15	
13072 - Photographer II	21.42	
13073 - Photographer III	24.53	
13074 - Photographer IV	27.45	
13075 - Photographer V	29.27	
13090 - Technical Order Library Clerk	21.42	
13110 - Video Teleconference Technician	19.15	
14000 - Information Technology Occupations		
14041 - Computer Operator I	15.71***	
14042 - Computer Operator II	17.22	
14043 - Computer Operator III	19.19	
14044 - Computer Operator IV	21.33	
14045 - Computer Operator V	23.62	
14071 - Computer Programmer I (see 1)	15.73***	
14072 - Computer Programmer II (see 1)	19.50	
14073 - Computer Programmer III (see 1)	23.84	
14074 - Computer Programmer IV (see 1)		
14101 - Computer Systems Analyst I (see 1)	24.23	
14102 - Computer Systems Analyst II (see 1)		
14103 - Computer Systems Analyst III (see 1)		
14150 - Peripheral Equipment Operator	15.71***	
14160 - Personal Computer Support Technician	21.33	
14170 - System Support Specialist	21.24	
15000 - Instructional Occupations		
15010 - Aircrew Training Devices Instructor (Non-Rated)	24.23	
15020 - Aircrew Training Devices Instructor (Rated)	29.32	
15030 - Air Crew Training Devices Instructor (Pilot)	34.91	
15050 - Computer Based Training Specialist / Instructor	24.23	
15060 - Educational Technologist	29.40	
15070 - Flight Instructor (Pilot)	34.91	
15080 - Graphic Artist	20.47	
15085 - Maintenance Test Pilot, Fixed, Jet/Prop	34.91	
15086 - Maintenance Test Pilot, Rotary Wing	34.91	
15088 - Non-Maintenance Test/Co-Pilot	34.91	
15090 - Technical Instructor	17.67	
15095 - Technical Instructor/Course Developer	23.78	
15110 - Test Proctor	15.70***	
15120 - Tutor	15.70***	
16000 - Laundry, Dry Cleaning, Pressing And Related Occupations		
16010 - Assembler	10.83***	
16030 - Counter Attendant	10.83***	
16040 - Dry Cleaner	12.36***	
16070 - Finisher, Flatwork, Machine	10.83***	
16080 - Presser, Hand	10.83***	
16110 - Presser, Machine, Drycleaning	10.83***	
16130 - Presser, Machine, Shirts	10.83***	
16160 - Presser, Machine, Wearing Apparel, Laundry	10.83***	
16190 - Sewing Machine Operator	12.88***	
16220 - Tailor	13.40***	
16250 - Washer, Machine	11.34***	
18000 - Machine Tool Operation And Repair Occupations		
18010 - Machine-Tool Operator (Tool Room)	19.46	
19040 - Tool And Die Maker	24.46	
21000 - Materials Handling And Packing Occupations		
21020 - Forklift Operator	15.36***	
21030 - Material Coordinator	22.97	
21040 - Material Expediter	22.97	
21050 - Material Handling Laborer	12.57***	
21071 - Order Filler	10.62***	
21080 - Production Line Worker (Food Processing)	15.36***	
21110 - Shipping Packer	17.12	
21130 - Shipping/Receiving Clerk	17.12	
21140 - Store Worker I	15.83***	
21150 - Stock Clerk	22.26	
21210 - Tools And Parts Attendant	15.36***	
21410 - Warehouse Specialist	15.36***	
23000 - Mechanics And Maintenance And Repair Occupations		
23010 - Aerospace Structural Welder	25.04	
23019 - Aircraft Log and Records Technician	19.47	
23021 - Aircraft Mechanic I	23.84	
23022 - Aircraft Mechanic II	25.04	
23023 - Aircraft Mechanic III	26.30	
23040 - Aircraft Mechanic Helper	16.58	
23050 - Aircraft, Painter	22.99	
23060 - Aircraft Servicer	19.47	
23070 - Aircraft Survival Flight Equipment Technician	22.39	
23080 - Aircraft Worker	21.03	
23091 - Aircrew Life Support Equipment (ALSE) Mechanic 2L03 I		
23092 - Aircrew Life Support Equipment (ALSE) Mechanic 23.84 II		

OCCUPATION CODE - TITLE FOOTNOTE RATE

23110 - Appliance Mechanic	19.46	
23120 - Bicycle Repairer	15.61***	RA7
23125 - Cabin Splitter	22.47	
23130 - Carpenter, Maintenance	17.58	
23140 - Carpet Layer	18.20	
23160 - Electrician, Maintenance	19.37	
23181 - Electronics Technician Maintenance I	18.20	
23182 - Electronics Technician Maintenance II	19.46	
23183 - Electronics Technician Maintenance III	20.72	
23260 - Fabric Worker	16.94	
23290 - Fire Alarm System Mechanic	18.77	
23310 - Fire Extinguisher Repairer	15.61***	
23311 - Fuel Distribution System Mechanic	20.72	
23312 - Fuel Distribution System Operator	15.61***	
23370 - General Maintenance Worker	13.24***	
23380 - Ground Support Equipment Mechanic	23.84	
23381 - Ground Support Equipment Servicer	19.47	
23382 - Ground Support Equipment Worker	21.03	
23391 - Gunsmith I	15.61***	
23392 - Gunsmith II	18.20	
23393 - Gunsmith III	20.72	
23410 - Heating, Ventilation And Air-Conditioning Mechanic	19.27	
23411 - Heating, Ventilation And Air Conditioning Mechanic (Research Facility)	20.50	
23430 - Heavy Equipment Mechanic	19.50	
23440 - Heavy Equipment Operator	18.20	
23460 - Instrument Mechanic	20.72	
23465 - Laboratory/Shelter Mechanic	19.46	
23470 - Laborer	12.57***	
23510 - Locksmith	19.46	
23530 - Machinery Maintenance Mechanic	23.13	
23550 - Machinist, Maintenance	20.72	
23580 - Maintenance Trades Helper	11.77***	
23591 - Metrology Technician I	20.72	
23592 - Metrology Technician II	22.83	
23593 - Metrology Technician III	23.33	
23640 - Millwright	20.72	
23710 - Office Appliance Repairer	19.46	
23760 - Painter, Maintenance	17.04	
23790 - Pipefitter, Maintenance	19.96	
23810 - Plumber, Maintenance	18.75	
23820 - Pneumatic Systems Mechanic	20.72	
23850 - Rigger	20.72	
23870 - Scale Mechanic	18.20	
23890 - Sheet-Metal Worker, Maintenance	19.55	
23910 - Small Engine Mechanic	18.20	
23931 - Telecommunications Mechanic I	19.96	
23932 - Telecommunications Mechanic II	21.24	
23950 - Telephone Lineman	20.62	
23960 - Welder, Combination, Maintenance	19.96	
23965 - Well Driller	21.13	
23970 - Woodcraft Worker	20.71	
23980 - Woodworker	15.61***	
24000 - Personal Needs Occupations		
24550 - Case Manager	15.01***	
24570 - Child Care Attendant	10.09***	
24580 - Child Care Center Clerk	13.25***	
24610 - Chores Aide	14.06***	
24620 - Family Readiness And Support Services Coordinator	15.01***	
24630 - Homemaker	16.12***	
25000 - Plant And System Operations Occupations		
25030 - Boiler Tender	22.79	
25040 - Sewage Plant Operator	22.89	
25070 - Stationary Engineer	22.79	
25190 - Ventilation Equipment Tender	15.72***	
25210 - Water Treatment Plant Operator	22.89	
27000 - Protective Service Occupations		
27004 - Alarm Monitor	10.90***	
27007 - Baggage Inspector	9.43***	
27008 - Corrections Officer	14.59***	
27010 - Court Security Officer	14.59***	
27030 - Detection Dog Handler	10.90***	
27040 - Detention Officer	14.59***	
27070 - Firefighter	14.59***	
27101 - Guard I	9.63***	
27102 - Guard II	10.90***	
27121 - Police Officer I	14.59***	
27132 - Police Officer II	16.21	
28000 - Recreation Occupations		
28041 - Carnival Equipment Operator	13.24***	
28042 - Carnival Equipment Repairer	14.46***	
28043 - Carnival Worker	9.78***	
28210 - Gate Attendant/Gate Tender	12.18***	

OCCUPATION CODE - TITLE FOOTNOTE RATE

28310 - Lifeguard	11.01***	
28350 - Park Attendant (Aide)	14.74***	
28510 - Recreation Aide/Health Facility Attendant	11.84***	
28515 - Recreation Specialist	18.26	
29000 - Stevedoring/Longshoremen Occupational Services		
29010 - Stevedore And Bracer	26.02	
29020 - Hatch Tender	26.02	
29030 - Line Handler	26.02	
29041 - Stevedore I	24.23	
29042 - Stevedore II	27.82	
30000 - Technical Occupations		
30030 - Air Traffic Control Specialist, Center (HFO) (see 2)	43.06	
30011 - Air Traffic Control Specialist, Station (HFO) (see 2)	28.89	
30012 - Air Traffic Control Specialist, Terminal (HFO) (see 2)	32.70	
30021 - Archeological Technician I	18.17	
30022 - Archeological Technician II	20.33	
30023 - Archeological Technician III	25.19	
30030 - Cartographic Technician	25.19	
30040 - Civil Engineering Technician	25.19	
30051 - Cryogenic Technician I	27.89	
30051 - Cryogenic Technician II	30.80	
30061 - Drafter/CAD Operator I	18.17	
30062 - Drafter/CAD Operator II	20.33	
30063 - Drafter/CAD Operator III	22.66	
30064 - Drafter/CAD Operator IV	27.89	
30081 - Engineering Technician I	16.18***	
30082 - Engineering Technician II	18.17	
30083 - Engineering Technician III	20.33	
30084 - Engineering Technician IV	25.19	
30085 - Engineering Technician V	30.80	
30086 - Engineering Technician VI	37.27	
30090 - Environmental Technician	25.19	
30095 - Evidence Control Specialist	25.19	
30210 - Laboratory Technician	22.66	
30221 - Latent Fingerprint Technician I	27.89	
30222 - Latent Fingerprint Technician II	30.80	
30240 - Mathematical Technicians	25.19	
30341 - Paralegal/Legal Assistant I	19.54	
30342 - Paralegal/Legal Assistant II	24.23	
30343 - Paralegal/Legal Assistant III	29.63	
30344 - Paralegal/Legal Assistant IV	35.83	
30375 - Petroleum Supply Specialist	30.80	
30390 - Photo-Optical Technician	24.92	
30395 - Radiation Control Technician	30.80	
30451 - Technical Writer I	25.19	
30452 - Technical Writer II	30.80	
30453 - Technical Writer III	37.27	
30491 - Unexploded Ordnance (UXO) Technician I	27.37	
30492 - Unexploded Ordnance (UXO) Technician II	33.11	
30493 - Unexploded Ordnance (UXO) Technician III	39.69	
30494 - Unexploded (UXO) Safety Escort	27.37	
30495 - Unexploded (UXO) Sweep Personnel	27.37	
30501 - Weather Forecaster I	27.99	
30502 - Weather Forecaster II	33.92	
30620 - Weather Observer, Combined Upper Air Or Surface Programs (see 2)	22.66	
30621 - Weather Observer, Senior (see 2)	25.19	
31000 - Transportation/Mobile Equipment Operation Occupations		
31010 - Airplane Pilot	81.31	
31020 - Bus Aide	8.97***	
31030 - Bus Driver	11.79***	
31043 - Driver Courier	10.26***	
31280 - Parking and Lot Attendant	9.91***	
31290 - Shuttle Bus Driver	11.65***	
31310 - Taxi Driver	11.43***	
31361 - Truckdriver, Light	13.21***	
31362 - Truckdriver, Medium	12.16***	
31363 - Truckdriver, Heavy	16.11***	
31364 - Truckdriver, Tractor-Trailer	16.11***	
99000 - Miscellaneous Occupations		
99020 - Cabin Safety Specialist	16.14***	
99020 - Cashier	10.01***	
99030 - Desk Clerk	9.71***	
99095 - Embalmer	27.37	
99130 - Flight Follower	27.37	
99251 - Laboratory Animal Caretaker I		
24.31		
99252 - Laboratory Animal Caretaker II		
26.56		
99260 - Marketing Analyst	21.54	
99310 - Mortician	27.37	
99410 - Pest Controller	16.07***	
99510 - Photofinishing Worker		
14.38***		
99710 - Recycling Laborer		
17.32		
99711 - Recycling Specialist		
23.38		
99730 - Refuse Collector	16.40	
99810 - Sales Clerk	10.63***	
99820 - School Crossing Guard	17.96	
99830 - Survey Party Chief	23.99	
99831 - Surveying Aide	13.65***	
99832 - Surveying Technician	17.73	
99840 - Vending Machine Attendant	24.31	
99841 - Vending Machine Repairer	30.96	

***Workers in this classification may be entitled to a higher minimum wage under Executive Order 14026 (\$16.20 per hour). Please see the Note at the top of the wage determination for more information. Please also note that the minimum wage requirements of Executive Order 14026 are not currently being enforced as to contracts or contract-like instruments entered into with the federal government in connection with seasonal recreational services or seasonal recreational equipment rental for the general public on federal lands.

ALL OCCUPATIONS LISTED ABOVE RECEIVE THE FOLLOWING BENEFITS:

HEALTH & WELFARE: \$4.98 per hour, up to 40 hours per week, or \$199.20 per week or \$863.20 per month

HEALTH & WELFARE EO 13706: \$4.57 per hour, up to 40 hours per week, or \$182.80 per week, or \$792.19 per month*

*This rate is to be used only when compensating employees for performance on an SCA-covered contract also covered by EO 13706, Establishing Paid Sick Leave for Federal Contractors. A contractor may not receive credit toward its SCA obligations for any paid sick leave provided pursuant to EO 13706.

VACATION: 2 weeks paid vacation after 1 year of service with a contractor or successor; and 4 weeks after 3 years. Length of service includes the whole span of continuous service with the present contractor or successor, whenever employed, and with the predecessor contractors in the performance of similar work at the same Federal facility. (Reg. 29 CFR 4.173) **HOLIDAYS:** A minimum of eleven paid holidays per year: New Year's Day, Martin Luther King Jr.'s Birthday, Washington's Birthday, Memorial Day, Juneteenth National Independence Day, Independence Day, Labor Day, Columbus Day, Veterans' Day, Thanksgiving Day, and Christmas Day. (A contractor may substitute for any of the named holidays another day off with pay in accordance with a plan communicated to the employees involved.) (See 29 CFR 4.174)

THE OCCUPATIONS WHICH HAVE NUMBERED FOOTNOTES IN PARENTHESES RECEIVE THE FOLLOWING:

1) **COMPUTER EMPLOYEES:** This wage determination does not apply to any individual employed in a bona fide executive, administrative, or professional capacity, as defined in 29 C.F.R. Part 541. (See 43 C.F.R. 6701(3)). Because most Computer Systems Analysts and Computer Programmers who are paid at least \$27.63 per hour for at least \$684 per week if paid on a salary or fee basis likely qualify as exempt computer professionals under 29 U.S.C. 213(a)(1) and 29 U.S.C. 213(a)(17), this wage determination may not include wage rates for all occupations within those job families. In such instances, a conformance will be necessary if there are nonexempt employees in these job families working on the contract.

Job titles vary widely and change quickly in the computer industry, and are not determinative of whether an employee is an exempt computer professional. To be exempt, computer employees who satisfy the compensation requirements must also have a primary duty that consists of:

- (1) The application of systems analysis techniques and procedures, including consulting with users, to determine hardware, software or system functional specifications;
- (2) The design, development, documentation, analysis, creation, testing or modification of computer systems or programs, including prototypes, based on and related to user or system design specifications;
- (3) The design, documentation, testing, creation or modification of computer programs related to machine operating systems; or
- (4) A combination of the aforementioned duties, the performance of which requires the same level of skills. (29 C.F.R. 541.400).

Any computer employee who meets the applicable compensation requirements and the above duties test qualifies as an exempt computer professional under both section 13(a)(1) and section 13(a)(17) of the Fair Labor Standards Act. (Field Assistance Bulletin No. 2006-3 (Dec. 14, 2006)). Accordingly, this wage determination will not apply to any exempt computer employee regardless of which of these two exemptions is utilized.

2) **AIR TRAFFIC CONTROLLERS AND WEATHER OBSERVERS - NIGHT PAY & SUNDAY PAY:** If you work at night as part of a regular tour of duty, you will earn a night differential and receive an additional 10% of basic pay for any hours worked between 6pm and 6am. If you are a full-time employee (40 hours a week) and Sunday is part of your regularly scheduled workweek, you are paid at your rate of basic pay plus a Sunday premium of 25% of your basic rate for each hour of Sunday work which is not overtime (i.e. occasional work on Sunday outside the normal tour of duty is considered overtime work).

**** HAZARDOUS PAY DIFFERENTIAL ****

An 8 percent differential is applicable to employees employed in a position that represents a high degree of hazard when working with or in close proximity to ordnance, explosives, and incendiary materials. This includes work such as screening, blending, drying, mixing, and pressing of sensitive ordnance, explosives, and pyrotechnic compositions such as lead azide, black powder and photoflash powder. All dry-house activities involving propellants or explosives. Demilitarization, modification, renovation, demolition, and maintenance operations on sensitive ordnance, explosives and incendiary materials. All operations involving re-grading and cleaning of artillery ranges.

A 4 percent differential is applicable to employees employed in a position that represents a low degree of hazard when working with, or in close proximity to ordnance, (or employees possibly adjacent to) explosives and incendiary materials which involves potential injury such as laceration of hands, face, or arms of the employee engaged in the operation, irritation of the skin, minor burns and the like; minimal damage to immediate or adjacent work area or equipment being used. All operations involving unloading, storage, and handling of ordnance, explosive, and incendiary ordnance material other than small arms ammunition. These differentials are only applicable to work that has been specifically designated by the agency for ordnance, explosives, and incendiary material differential pay.

**** UNIFORM ALLOWANCE ****

If employees are required to wear uniforms in the performance of this contract (either by the terms of the Government contract, by the employer, by the state or local law, etc.), the cost of furnishing such uniforms and maintaining (by laundering or dry cleaning) such uniforms is an expense that may not be borne by an employee where such cost exceeds the hourly rate below that required by the wage determination. The Department of Labor will accept payment in accordance with the following standards as compliance:

The contractor or subcontractor is required to furnish all employees with an adequate number of uniforms without cost or to reimburse employees for the actual cost of the uniforms. In addition, where uniform cleaning and maintenance is made the responsibility of the employee, all contractors and subcontractors subject to this wage determination shall (in the absence of a bona fide collective bargaining agreement providing for a different amount, or the furnishing of contrary affirmative proof as to the actual cost), reimburse all employees for such cleaning and maintenance at a rate of \$3.35 per week (or \$6.67 cents per day). However, in those instances where the uniforms furnished are made of "wash and wear" materials, may be routinely washed and dried with other personal garments, and do not require any special treatment such as dry cleaning, daily washing, or commercial laundering in order to meet the cleanliness or appearance standards set by the terms of the Government contract, by the contractor, by law, or by the nature of the work, there is no requirement that employees be reimbursed for uniform maintenance costs.

**** SERVICE CONTRACT ACT DIRECTORY OF OCCUPATIONS ****

The duties of employees under job titles listed are those described in the "Service Contract Act Directory of Occupations", FRRh Edition (Revision 1), dated September 2015, unless otherwise indicated.

**** REQUEST FOR AUTHORIZATION OF ADDITIONAL CLASSIFICATION AND WAGE RATE, Standard Form 1444 (SF-1444) ****

Conformance Process: The contracting officer shall require that any class of service employee which is not listed herein and which is to be employed under the contract (i.e., the work to be performed is not performed by any classification listed in the wage determination), be classified by the contractor so as to provide a reasonable relationship (i.e., appropriate level of skill comparison) between such unlisted classifications and the classifications listed in the wage determination (See 29 CFR 4.6(b)(2)(iv)). Such conforming procedures shall be initiated by the contractor prior to the performance of contract work by such unlisted class(es) of employees (See 29 CFR 4.6(b)(2)(iii)). The Wage and Hour Division shall make a final determination of conformed classification, wage rate, and/or fringe benefits which shall be paid to all employees performing in the classification from the first day of work on which contract work is performed by them in the classification. Failure to pay such unlisted employees the compensation agreed upon by the interested parties and/or fully determined by the Wage and Hour Division retroactive to the date such class of employees commenced contract work shall be a violation of the Act and this contract. (See 29 CFR 4.6(b)(2)(v)). When multiple wage determinations are included in a contract, a separate SF-1444 should be prepared for each wage determination to which a class(es) is to be confirmed.

The process for preparing a conformance request is as follows:

- 1) When preparing the bid, the contractor identifies the need for a conformed occupation(s) and computes a proposed rate(s).
- 2) After contract award, the contractor prepares a written report listing in order the proposed classification title(s), a federal grade equivalent (FGE) for each proposed classification(s), job description(s), and rationale for proposed wage rate(s), including information regarding the agreement or disagreement of the authorized representative of the employees involved, or where there is no authorized representative, the employees themselves. This report should be submitted to the contracting officer no later than 30 days after such unlisted class(es) of employees performs any contract work.
- 3) The contracting officer reviews the proposed action and promptly submits a report of the action, together with the agency's recommendations and pertinent information including the position of the contractor and the employees, to the U.S. Department of Labor, Wage and Hour Division, for review (See 29 CFR 4.6(b)(2)(ii)).
- 4) Within 30 days of receipt, the Wage and Hour Division approves, modifies, or disapproves the action via transmittal to the agency contracting officer, or notifies the contracting officer that additional time will be required to process the request.
- 5) The contracting officer transmits the Wage and Hour Division's decision to the contractor.

6) Each affected employee shall be furnished by the contractor with a written copy of such determination or it shall be posted as a part of the wage determination (See 29 CFR 4.4(b)(2)(B))

Information required by the Regulations must be submitted on SF-1444 or bond paper.

When preparing a conformance request, the "Service Contract Act Directory of Occupations" should be used to compare job definitions to ensure that duties requested are not performed by a classification already listed in the wage determination. Remember, it is not the job title, but the required tasks that determine whether a class is included in an established wage determination. Conformances may not be used to artificially split, combine, or subdivide classifications listed in the wage determination (See 29 CFR 4.152(c)(1))."

DECLARATION RE: NON-COLLUSION
(AG FORM 003)

Pete Plerson [state name of declarant signing below], declares that:

1. The name of the bidding/offering company or individual is [state name of company]
Federal Contract Corp

2. The Bid/Proposal for the solicitation identified above is genuine and not collusive or a sham. The bidder/offeree has not colluded, conspired, connived or agreed, directly or indirectly, with any other bidder/offeree or person, to put in a sham bid/proposal or to refrain from making an offer. The bidder/offeree has not in any manner, directly or indirectly, sought by an agreement or collusion, or communication or conference, with any person to fix the proposal price of bidder/offeree or of any other bidder/offeree, or to fix any overhead, profit or cost element of said proposal price, or of that of any other bidder/offeree, or to secure any advantage against the government of Guam or any other bidder/offeree, or to secure any advantage against the government of Guam or any person interested in the proposed contract. All statements in this affidavit and in the proposal are true to the best of the knowledge of the undersigned. This statement is made pursuant to 2 GAR Division 4 § 3126(b).

3. I make this statement on behalf of myself as a representative of the bidder/offeree, and on behalf of the bidder/offeree's officers, representatives, agents, subcontractors, and employees.

I hereby declare under penalty of perjury under the laws of Guam that the foregoing is true and correct.



Signature of one of the following:

Offeror, if the bidder/offeree is an individual;
Partner, if the bidder/offeree is a partnership;
Officer, if the bidder/offeree is a corporation.

**DECLARATION DISCLOSING OWNERSHIP, INFLUENCE, COMMISSIONS
AND CONFLICTS OF INTEREST**
(Required by 5 GCA § 5233 as amended by P.L. 36-13 (4/9/2021))

Preface. As a condition of submitting a Bid/Offer/Proposal or responding to any method of source selection under Guam's Procurement Law for the purpose of entering into a contract with the government of Guam, this Affidavit requires all Bidders/Offerors/Prospective Contractors to make disclosures of ownership, influence, commissions, gratuities, kickbacks, and conflicts of interest occurring during the 365 calendar days preceding the publication of this solicitation and until award of a contract. This includes the duty to disclose any changes to the facts disclosed herein throughout the solicitation process; and if the entity submitting this Affidavit is awarded a contract, the duty to disclose any changes to the facts disclosed herein continues throughout the life of the contract, including any extensions or renewals.

A. I, the undersigned, hereby declare that I am an authorized representative of the Bidder/Offeror/Prospective Contractor and that (please check and fill out all that apply):

The Bidder/Offeror/Prospective Contractor is an individual with a business license, and all decisions are by, and all profit is for, that same individual, with principal place of business street address being:

The Bidder/Offeror/Prospective Contractor is a business or artificial person (as defined in 1 GCA § 715 or 5 GCA §§ 5030(n) or 5233(b)), and is a sole proprietorship owned entirely (100%) by _____, with principal place of business street address being:

The Bidder/Offeror/Prospective Contractor is a business or artificial person (as defined in 1 GCA § 715 or 5 GCA §§ 5030(n) or 5233(b)), and is owned by the following multiple individuals. Note: owners of more than 10% are statutorily required to be listed below, but other owners of smaller percentage are encouraged to be listed as well.

Name of Owner	Principal Place of Business Street Address	% of Interest
Clark Ricke	12918 N. Nebraska Ave	51%
Steve Ricke	**	16.3%
Chris Rey	**	16.3%
Pete Pearson	**	16.3%

One or more of the more-than-10% owners listed above is a business or artificial person. Any more-than-25% owners of such a business or artificial person are listed below per 5 GCA § 5233. Note: any less-than-25% owners of such a business or artificial person is encouraged to also be listed below.

Name of >10% Owner Business or Artificial Person:

Names of owners of the >10% Owner Business or Artificial Person ("Second Tier Owner")	Owner's Principal Place of Business Street Address	% of Interest

Name of other >10% Owner Business or Artificial Person:

Names of owners of the >10% Owner Business or Artificial Person ("Second Tier Owner")	Owner's Principal Place of Business Street Address	% of Interest

B. If any Second Tier Owner identified above is an artificial person, the natural or artificial owners of such Second Tier Owner who have held more than 49% of the shares or interest in the Bidder/Offeror/Prospective Contractor (Third Tier Owners) are as follows (if none, please so state):

Second Tier Owner Name _____

Name of Third Tier Owner	Principal Place of Business Street Address	% of Interest
_____	_____	_____
_____	_____	_____
_____	_____	_____

C. If the name of no natural person has been identified as an owner, or a Second or Third Tier Owner of the Bidder/Offeror/Prospective Contractor, please identify the name, position, address, and contact information of the natural person having the authority and responsibility for the Bid/Offer/Proposal/Prospective Contract, and the name of any natural person who has the authority and power to remove and replace the designated responsible person:

Name of Natural Person	Position	Street Address of Principal Place of Business	Phone Number, Email Address, and other Contact Information

D. Further, I say that the persons who have received or are entitled to receive a commission, gratuity, contingent fee or other compensation to solicit, secure, or assist in obtaining business related to the Bid/Offer/Proposal/Prospective Contract for which this Affidavit is submitted are as follows (if none, please so state):

Name	Principal Place of Business Street Address	Amount of Compensation
_____	_____	_____
_____	_____	_____

E. Further, I say that the persons who have directly or indirectly participated in this solicitation and who are also employees of the government of Guam or the government of the United States, if federal funds are to be used

In the payment of the contract related to the Bid/Offer/Proposal/Prospective Contract for which this Affidavit is submitted, are as follows (if none, please so state):

Name	Principal Place of Business Street Address
_____	_____
_____	_____

F. Regardless of any ownership interest, the following individuals have the power to control the performance of the contract or to control the Bidder/Offeror/Prospective Contractor, directly or indirectly:

Name	Principal Place of Business Street Address
_____	_____
_____	_____

G. Until award of the contract, and throughout the term of any contract awarded to the Bidder/Offeror/Prospective Contractor represented herein, I agree to promptly make any disclosures not made previously and update changes in ownership, identities of owners and other required information, interests, compensation or conflicts of the persons required to be disclosed. I understand that failure to comply with this requirement shall constitute a material breach of contract.

H. I hereby declare under penalty of perjury under the laws of Guam that the foregoing is true and correct.

Executed on: 05/07/2024 (date)



Signature of one of the following:
Bidder/Offeror/Prospective Contractor, if a licensed individual
Owner of sole proprietorship Bidder/Offeror/Prospective
Contractor
Partner, if the Bidder/Offeror/Prospective Contractor is a
partnership
Officer, if the Bidder/Offeror/Prospective Contractor is a
corporation

AG Procurement Form 002 (Substitution)

DECLARATION RE: CONTINGENT FEES
(AG Form 007)

Pete Pierson [state name of declarant signing below], hereby declares that:

1. The name of the bidding/offering company or individual is [state name of company]

Federal Contracts Corp

2. As a part of the bidding/offering company's bid or proposal, to the best of my knowledge, the offering company has not retained any person or agency on a percentage, commission, or other contingent arrangement to secure this contract. This statement is made pursuant to 2 GAR Division 4 § 11108(f).

3. As a part of the bidding/offering company's bid or proposal, to the best of my knowledge, the bidding/offering company has not retained a person to solicit or secure a contract with the government of Guam upon an agreement or understanding for a commission, percentage, brokerage, or contingent fee, except for retention of bona fide employees or bona fide established commercial selling agencies for the purpose of securing business. This statement is made pursuant to 2 GAR Division 4 § 11108(f).

4. I make these statements on behalf of myself as a representative of the bidder/offering company, and on behalf of the Bidder/Offerors officers, representatives, agents, subcontractors, and employees.

I hereby declare under penalty of perjury under the laws of Guam that the foregoing is true and correct.

Pete Pierson

Signature of one of the following:

Bidder/Offeror, if the bidder/offering company is an individual; Partner, if the bidder/offering company is a partnership; Officer, if the bidder/offering company is a corporation.

**GOVERNMENT OF GUAM
GENERAL TERMS AND CONDITIONS
SEALED BID SOLICITATION AND AWARD**

Only those Boxes checked below are applicable to this bid.

1. **AUTHORITY:** This solicitation is issued subject to all the provision of the Guam Procurement Act (SGCA, Chapter 5) and the Guam Procurement Regulations (copies of both are available at the Office of the Comptroller of Laws, Department of Law, copies available for inspection at the PORT AUTHORITY OF GUAM). It requires all parties involved in the Preparation, negotiation, performance, or administration of contracts to act in good faith.
2. **GENERAL INTENTION:** Unless otherwise specified, it is the declared and acknowledged intention and meaning of these General Terms and conditions for the bidder to provide the Government of Guam (Government) with specified services or with materials, supplies or equipment completely assembled and ready for use.
3. **TAXES:** Bidders are cautioned that they are subject to Guam Income Taxes as well as all other taxes on Guam Transactions. Specific information on taxes may be obtained from the Director of Revenue and Taxation.
- WITHHOLDING ASSESSMENT FEE:** All procurements of professional services are subject to a withholding assessment fee for non-resident persons or companies without a valid Guam Business License, which is equal to four percent (4%) of the total dollar value of any contract awarded for all government of Guam contracts for any professional services provided by a non-resident person or company residing outside of Guam, as a cost of doing business with the government of Guam, in accordance with 11 GCA § 71114 (P.L. 33-166).
4. **LICENSING:** Bidders are cautioned that the Government will not consider for award any offer submitted by a bidder who has not complied with the Guam Licensing Law. Specific information on licenses may be obtained from the Director of Revenue and Taxation.
5. **NO LOCAL PROCUREMENT PREFERENCE:** There is no geographical preference for this IFB in compliance with 2 CFR § 200.319(c) and the terms and conditions of MARAD FY2022 American Marine Highway (AMH) Grant No.: 693HF72340007; however, no specification, term, condition, or qualification of this IFB shall exclude any Offeror from consideration on the basis of Guam-only experience provided that the experience of such Offeror is otherwise responsive to the solicitation, in accordance with the requirements of 5 GCA § 5006(e).
6. **COMPLIANCE WITH SPECIFICATIONS AND OTHER SOLICITATION REQUIREMENTS:** Bidders shall comply with all specifications and other requirements of the Solicitation.
7. **"ALL OR NONE" BIDS: NOTE:** By checking this item, the Government is requesting all of the bid items to be bid or none at all. ~~The Government will not award on an itemized basis.~~
8. **INDEPENDENT PRICE DETERMINATION:** The bidder, upon signing the invitation for bid, certifies that the prices in his bid were derived at without collusion, and acknowledge that collusion and anti-competitive practices are prohibited by law. Violations will be subject to the provision of Section 5631 of that of the Guam Procurement Act. Other existing civil, criminal or administrative remedies are not impaired and may be in addition to the remedies in Section 5631 of the Government code.
9. **BIDDER'S PRICE:** The Government will consider not more than two (2) (Basic and Alternate) item prices and the bidder shall explain fully each price if supplies, materials, equipment, and/or specified services offered comply with specifications and the products origin. Where basic or alternate bid meets the minimum required specification, cost and other factors will be considered. Failure to explain this requirement will result in rejection of the bid.
10. **BID ENVELOPE:** Envelope shall be sealed and marked with the bidder's name, Bid number, time, date and place of Bid Opening.
11. **BID GUARANTEE REQUIREMENT:** Bidder is required to submit a Bid Guarantee Bond or standby Irrevocable Letter of Credit or Certified Check or Cashier's Check in the same bid envelope to be held by the Government pending award. The Bid Guarantee Bond, Letter of Credit, Certified Check or Cashier's Check must be issued by any local surety or banking institution licensed to do business on Guam and made payable to the Treasurer of Guam in the amount of fifteen percent (15%) of his highest total bid offer. The Bid Bond must be submitted on Government Standard Form BB-1 (copy enclosed). Personal Checks will not be accepted as Bid Guarantee. If a successful Bidder (contractor) withdraws from the bid or fails to enter into contract within the prescribed time, such Bid Guarantee will be forfeited to the Government of Guam. Bids will be disqualified if not accompanied by Bid Bond, Letter of Credit, Certified Check or Cashier's check. Bidder must include in his/her bid, valid copies of a Power of Attorney from the Surety and a Certificate of Authority from the Government of Guam to show proof that the surety company named on the bond instrument is authorized by the Government of Guam and qualified to do business on Guam. For detailed information on bonding matters, contact the Department of Revenue and Taxation. Failure to submit a valid Power of Attorney and Certificate of Authority on the surety is cause for rejection of bid. Pursuant to 5 GCA § 5212, all competitive sealed bidding for the procurement of supplies or services exceeding \$25,000.00 a 15% Bid Security of the total bid price must accompany the bid package. The bid bond, Letter of Credit, Certified Check or Cashier's Check will serve as Bid Security for this procurement. No award shall be given until bid security is confirmed.
12. **PERFORMANCE GUARANTEE:** Bidders who are awarded a contract under this solicitation, guarantee that goods will be delivered or required services performed within the time specified. Failure to perform the contract in a satisfactory manner may be cause for suspension or debarment from doing business with the Government of Guam. In addition, the Government will hold the Vendor liable and will enforce the requirements as set forth in Section 40 of these General Terms and Conditions.
13. **SURETY BONDS:** Bid and Bid Bonds coverage must be signed or countersigned in Guam by a foreign or alien surety's resident general agent. The surety must be an insurance Company, authorized by the government of Guam and qualified to do business in Guam. Bids will be disqualified if the Surety Company does not have a valid Certificate of Authority from the Government of Guam to conduct business in Guam.
14. **COMPETENCY OF BIDDERS:** Bids will be considered only from such bidders who, in the opinion of the Government, can show evidence of their ability, experience, equipment, and facilities to render satisfactory service.
15. **DETERMINATION OF RESPONSIBILITY OF BIDDERS:** The GENERAL MANAGER reserves the right for securing from Bidders information to determine whether or not they are responsible and to inspect plant site, place of business; and supplies and services as necessary to determine their responsibility in accordance with Section 15 of these General Terms and Conditions.
(2 GAR, Div. 4 § 3116)

- (X) 16. **STANDARD FOR DETERMINATION OF LOWEST RESPONSIBLE BIDDER:**
In determining the lowest responsible offer, the GENERAL MANAGER shall be guided by the following:
- a) Price of items offered.
 - b) The ability, capacity, and skill of the Bidder to perform.
 - c) Whether the Bidder can perform promptly or within the specified time.
 - d) The quality of performance of the Bidder with regards to awards previously made to him
 - e) The previous and existing compliance by the Bidder with laws and regulations relative to procurement.
 - f) The sufficiency of the financial resources and ability of the Bidder to perform.
 - g) The ability of the bidder to provide future maintenance and services for the subject of the award.
 - h) The compliance with all of the conditions to the Solicitation.
- (X) 17. **THE BIDS:** If the bids are for the same unit price or total amount in the whole or in part, the GENERAL MANAGER will determine award based on 2 GAR, Div. 4, § 3109(o) (2) or to reject all such bids.
- (X) 18. **BRAND NAMES:** Any reference in the Solicitation to manufacturer's Brand Names and number is due to lack of a satisfactory specification of commodity description. Such preference is intended to be descriptive, but not restrictive and for the sole purpose of indicating prospective bidders a description of the article or services that will be satisfactory. Bids on comparable items will be considered provided the bidder clearly states in his bid the exact articles he is offering and how it differs from the original specification.
- (X) 19. **DESCRIPTIVE LITERATURE:** Descriptive literature(s) as specified in this solicitation must be furnished as a part of the bid and must be received at the date and time set for opening Bids. The literature furnished must clearly identify the item(s) in the Bid. The descriptive literature is required to establish, for the purpose of evaluation and award, details of the product(s) the bidder proposes to furnish including design, materials, components, performance characteristics, methods of manufacture, construction, assembly or other characteristics which are considered appropriate. Rejection of the Bid will be required if the descriptive literature(s) do not show that the product(s) offered conform(s) to the specifications and other requirements of this solicitation. Failure to furnish the descriptive literature(s) by the time specified in the Solicitation will require rejection of the bid.
- [] 20. **SAMPLES:** Sample(s) of item(s) as specified in this solicitation must be furnished as a part of the bid and must be received at the date and time set for opening Bids. The sample(s) should represent exactly what the bidder proposes to furnish and will be used to determine if the item(s) offered complies with the specifications. Rejection of the Bid will be required if the sample(s) do not show that the product(s) offered conform(s) to the specifications and other requirements of this solicitation. Failure to furnish the sample(s) by the time specified in the Solicitation will require rejection of the bid.
- [] 21. **LABORATORY TEST:** Successful bidder is required to accompany delivery of his goods with a Laboratory Test Report indicating that the product he is furnishing the Government meets with the specifications. This report is on the bidder's account and must be from a certified Testing Association.
- (X) 22. **AWARD, CANCELLATION, & REJECTION:** Award shall be made to the lowest responsible and responsive bidder, whose bid is determined to be the most advantageous to the Government, taking into consideration the evaluation factors set forth in this solicitation. No other factors or criteria shall be used in the evaluation. The right is reserved as the interest of the Government may require to waive any minor irregularity in bid received. The GENERAL MANAGER shall have the authority to award, cancel, or reject bids, in whole or in part for any one or more items if he determines it is in the public interest. Award issued to the lowest responsible bidder within the specified time for acceptance as indicated in the solicitation, results in a bidding contract without further action by either party. In case of an error in the extension of prices, unit price will govern. It is the policy of the Government to award contracts to qualified local bidders. The Government reserves the right to increase or decrease the quantity of the items for award and make additional awards for the same type items and the vendor agrees to such modifications and additional awards based on the bid prices for a period of thirty (30) days after original award. No award shall be made under this solicitation which shall require advance payment or irrevocable letter of credit from the government (2 GAR, Div.4 §1103).
- [] 23. **MARKING:** Each outside container shall be marked with the Purchase Order number, item number, brief item description and quantity. Letter marking shall not be less than 3/4" in height.
- (X) 24. **SCHEDULE FOR DELIVERY:** Successful bidder shall notify the PORT AUTHORITY OF GUAM, Telephone Nos. 477-5931, at least twenty-four (24) hours before delivery of any item under this solicitation.
- [] 25. **BILL OF SALE:** Successful supplier shall render Bills of Sale for each item delivered under this contract. Failure to comply with this requirement will result in rejection of delivery. The Bill of Sale must accompany the items delivered but will not be considered as an invoice for payment. Supplier shall bill the Government in accordance with billing instructions as indicated on the Purchase Order.
- (X) 26. **MANUFACTURER'S CERTIFICATE:** Successful bidder is required, upon delivery of any item under this contract, to furnish a certificate from the manufacturer indicating that the goods meet the specifications. Failure to comply with this request will result in rejection of delivery payment. Supplier shall bill the Government in accordance with billing instructions as indicated on the Purchase Order.
- (X) 27. **INSPECTION:** All supplies, materials, equipment, or services delivered under this contract shall be subject to the inspection and/or test conducted by the Government at destination. If in any case the supplies, materials, equipment, or services are found to be defective in material, workmanship, performance, or otherwise do not conform with the specifications, the Government shall have the right to reject the items or require that they be corrected. The number of days required for correction will be determined by the Government.
- [] 28. **MOTOR VEHICLE SAFETY REQUIREMENTS:** The Government will only consider bids on motor vehicles which comply with the requirements of the National Traffic and Motor Vehicle safety Act of 1965 (Public Law 89-563) and Clean Air Act as amended (Public Law 88-206), that are applicable to Guam. Bidders shall state if the equipment offered comply with these aforementioned Federal Laws.
- [] 29. **SAFETY INSPECTION:** All motor vehicles delivered under this contract must pass the Government of Guam Vehicle inspection before delivery at destination.
- (X) 30. **GUARANTEE:**
a) Guarantee of Vehicle Type of Equipment:

The successful bidder shall guarantee vehicular type of equipment offered against defective parts, workmanship, and performance, for a period of not less than one (1) year after date of receipt of equipment. Bidder shall also provide service to the equipment for at least one (1) year. Service to be provided shall include, but will not be limited to tune ups (change of spark plugs, contact points and condensers) and lubrication (change of engine and transmission oil). All parts and labor shall be at the expense of the bidder. All parts found defective and not caused by misuse, negligence or accident within the guarantee period shall be repaired, replaced, or adjusted within six (6) working days after notice from the Government and without cost to the Government. Vehicular type of equipment as used in this context shall include equipment used for transportation as differentiated from tractors, backhoes, etc.

b) Guarantee of Other Type of Equipment:

The successful bidder shall guarantee all other types of equipment offered, except those mentioned in 30a, above, against defective parts, workmanship, and performance for a period of not less than three (3) months after date of receipt of equipment. Bidder shall also provide service to the equipment for at least three (3) months. All parts found defective within that period shall be repaired or replaced by the Contractor without cost to the Government. Repairs, adjustments or replacements of defective parts shall be completed by the contractor within six (6) working days after notice from the Government.

(c) Compliance with this Section is a condition of this Bid.

- [X] 31. **REPRESENTATION REGARDING ETHICS IN PUBLIC PROCUREMENT:** The bidder or contractor represents that it has not knowingly influenced and promises that it will not knowingly influence a Government employee to breach any of the ethical standards and represents that it has not violated, is not violating, and promises that it will not violate the prohibition against gratuities and kickbacks set forth on Chapter 11 (Ethics in Public Contracting) of the Guam Procurement Act and in Chapter 11 of the Guam Procurement Regulations.
- [X] 32. **REPRESENTATION REGARDING CONTINGENT FEES:** The contractor represents that it has not retained a person to solicit or secure a Government contract upon an agreement or understanding for a commission, percentage, brokerage, or contingent fee, except for retention of bona fide employees or bona fide established commercial selling agencies for the purpose of securing business (GPR Section 11-207).
- [X] 33. **EQUAL EMPLOYMENT OPPORTUNITY:** Contractors shall not discriminate against any employee or applicant of employment because of race, color, religion, sex, or national origin. The contractor will take affirmative action to ensure that employees are treated equally during employment without regards to their race, color, religion, sex, or national origin.
- [X] 34. **COMPLIANCE WITH LAWS:** Bidders awarded a contract under this Solicitation shall comply with the applicable standard, provisions, and stipulations of all pertinent Federal and/or local laws, rules, and regulations relative to the performance of this contract and the furnishing of goods.
- [X] 35. **CHANGE ORDER:** Any order issued relative to awards made under this solicitation will be subject to and in accordance with the provisions of Section 6-101-03.1 of the Guam Procurement Regulations.
- [X] 36. **STOP WORK ORDER:** Any stop work order issued relative to awards made under this solicitation will be subject to and in accordance with the provisions of Section 6-101-04.1 of the Guam Procurement Regulations.
- [X] 37. **CANCELLATION OF INVITATION FOR BIDS OR REQUEST FOR PROPOSALS:** Any invitation for Bid may be cancelled, or any or all bids or proposals may be rejected in whole or in part as may be specified in the solicitation, when it is in the best interests of the Territory in accordance with regulations promulgated by the Policy Office. The reasons therefor shall be made part of the contract file.
- [X] 38. **TIME FOR COMPLETION:** It is hereby understood and mutually agreed by and between the contractor and the Government that the time for delivery to final destination or the timely performance of certain services is an essential condition of this contract. If the contractor refuses or fails to perform any of the provisions of this contract within the time specified in the Purchase Order (from the date Purchase Order is acknowledged by vendor), then the contractor is in default. Defaults will be treated subject to and in accordance with the provisions of 2 GAR, Div. 4 § 6101(8)
- [X] 39. **JUSTIFICATION OF DELAY:** Bidders who are awarded contracts under this Solicitation, guarantee that the goods will be delivered to their destination or required services rendered within the time specified. If the bidder is not able to meet the specified delivery date, he is required to notify the GENERAL MANAGER of such delay. Notification shall be in writing and shall be received by the GENERAL MANAGER at least twenty-four (24) hours before the specified delivery date. Notification of delay shall include an explanation of the causes and reasons for the delay including statement(s) from supplier or shipping company causing the delay. The Government reserves the right to reject delay justification if, in the opinion of the GENERAL MANAGER, such justification is not adequate.
- [X] 40. **SERVICE-DISABLED VETERAN OWNED BUSINESS PREFERENCE:** Bidding is subject to the policy in favor of Service-Disabled Veteran Owned Business as defined in 5 GCA sections 5011 and 5012.
- [X] 41. **LIQUIDATED DAMAGES:** When the contractor is given notice of delay or nonperformance as specified in Paragraph 1 (Default) of the Termination for Default Clause of this contract and fails to cure in the time specified, the contractor shall be liable for damages for delay in the amount of one-fourth of one percent (1%) of outstanding order per calendar day from date set for cure until either the territory reasonable obtains similar supplies or services if the contractor is terminated for default, or until the contractor provides the supplies or services if the contractor is not terminated for default. To the extent that the contractor's delay or nonperformance is excused under Paragraph 40 (Excuse for Nonperformance or Delayed Performance) of the Termination for Default Clause of this contract, liquidated damages shall not be due the territory. The contractor remains liable for damages caused other than by delay. 2 GAR, Div. 4 §6101(d).
- [X] 42. **PHYSICAL LIABILITY:** If it becomes necessary for the Vendor, either as principal, agent or employee, to enter upon the premises or property of the Government of Guam in order to construct, erect, inspect, make delivery or remove property hereunder, the Vendor hereby covenants and agrees to take, use, provide and make all proper, necessary and sufficient precautions, safeguards and protections against the occurrence of any accidents, injuries or damages to any person or property during the progress of the work herein covered, and to be responsible for, and to indemnify and save harmless the Government of Guam from the payment of all sums of money by reason of all or any such accidents, injuries or damages that may occur upon or about such work, and fines, penalties and loss incurred for or by reasons of the violations of any territorial ordinance, regulations, or the laws of Guam or the United States, while the work is in progress. Contractor will carry insurance to indemnify the Government of Guam against any claim for loss, damage or injury to property or persons arising out of the performance of the Contractor or his employees and agents of the services covered by the contract and the use, misuse or failure of any equipment used by the contractor or his employees or agents, and shall provide certificates of such insurance to the Government of Guam when required.

[X] 43. **INSURANCE COVERAGE REQUIRED:** The amount of insurance required shall be determined by the Port's General Manager depending upon the type of activity conducted, or to be conducted by the owners or operators of vehicles entering the Port's facilities other service providers accessing on foot.

- A. Commercial General Liability including Broad Form Property Damage and Contractual Liability \$1,000,000.00 combined single limit of liability
- B. Worker's Compensation - Statutory
- C. Automobile Liability - \$1,000,000.00 combined single limit of liability

Insurance Company: The insurance coverage(s) must be issued by those insurance companies who are licensed to do business on Guam, as determined by the Insurance Commissioner of the Department of Revenue and Taxation

Additional Insurance Provision: All Commercial insurance policies possessed by owners or operators of vehicles entering or using the Port's facilities and/or grounds must name the Port as an additional insured in their policies and specify that the Port shall be given at least thirty (30 days' prior written notice of any cancellation, material change or reduction in coverage.

Proof of insurance: An Insurance Certificate must be issued listing all the vehicles, equipment, trucks covered under the insurance policy and filed with the Port Police Division. The insurance should include;

Name of the Insured (The Port must be shown as an Additional Insured on all Commercial insurance policies)

- Policy Number
- Effective Date of Policy
- Limits of Insurance
- Description of Coverage Provided; and
- Name of Issuing Company

A certified copy of the Insurance Certificate must be carried in each vehicle, equipment and/or truck entering the Port facilities. This proof of insurance must be provided to the Port Police Division on an annual basis at least ten (10) days before the insurance policy expires.

Notice of loss: In the event a Port tenant or user is involved in an accident within the Port's facilities or while on Routes 11A or 11B (Cabrera Highway) and results in bodily injury or property damage, the Port Police Division must be immediately notified.

Workers' Compensation: All business entities entering or using the Port's facilities must also possess Workers' Compensation insurance coverage as prescribed by Guam laws and copies of such Certificate of Insurance are to be filed with the Port Police Division. Each certification shall specify that the Port shall be given at least thirty (30) days prior written notice of any cancellation, material change or reduction in coverage.

Interchange Agreement: In lieu of fulfilling the maximum the maximum insurance requirements listed herein, the Port user must provide to the Port a current Interchange Agreement. The primary company must have fulfilled the maximum insurance requirements listed above. The Interchange Agreement must specifically state and name the Port user as additional insured and the duration of coverage. The Port must be notified thirty (30) days prior written notice of any cancellation, materials change or reduction in coverage.

[X] 44. Contract will be cancelled if funds not appropriated or insufficient, and that government will timely inform contractor. 2 GAR, Div.4 §3121(e) (1) (C) and 2 GAR, Div.4 § 3121(e)(1)(D).

[] 45. If cancelled, contractor will be reimbursed unamortized reasonably incurred non-recurring costs 2 GAR, Div.4 § 3121(e) (1) (G)

[X] 46. **CONTACT FOR CONTRACT ADMINISTRATION:** If your firm receives a contract as a result of this solicitation, please designate a person whom we may contact for prompt administration.

[X] 47. **WOMEN-OWNED BUSINESS PREFERENCE:** Bidding is subject to the policy in favor of Women-Owned Businesses pursuant to "The Support for Women-Owned Business Act" enacted by Public Law No. 36-26 and codified in 5 GCA section 5013.

[X] 48. **FEDERAL GSA SCHEDULES:** This IFB is federally funded under MARAD FY2022 American Marine Highway (AMH) Grant No.: 693JF72340007. The Port Authority of Guam is accepting Federal GSA pricing inclusive with shipping cost to Guam. If the bid pricing existing on the Federal GSA website from a qualified vendor for qualifying items on the date of opening of the bids, plus the confirmed price of shipping costs to Guam, confirmed after the opening of the bids, is the lowest price, then the contract will be awarded to that vendor.

[X] 49. **SIGNATURES**

This Agreement may be signed by the parties electronically, and in any number of counterparts, each of which shall be deemed an original, but all of which together shall constitute one and the same instrument. Delivery of an executed counterpart by one party to the other may be made by electronic transmission.

Name: Pete Pierson Title: Vice President
Address: 12918 N. Mabraeka Ave Telephone: 813-631-0000
Tampa, FL 33612

GOVERNMENT OF GUAM

SEALED BID SOLICITATION INSTRUCTIONS

1. **BID FORMS:** Each bidder shall be provided with one (1) sets of Solicitation forms. Additional copies may be provided upon request. Bidders requesting additional copies of said forms will be charged per page in accordance with 5 GCA § 10203 of the Government Code of Guam. All payments for this purpose shall be by cash, certified check or money order and shall be made payable to the PORT AUTHORITY OF GUAM (EO 86-24).
2. **PREPARATIONS OF BIDS:**
 - 2.0 Bidders are required to examine the drawings, specifications, schedule, and all instructions. Failure to do so will be at bidder's risk.
 - 2.1 Each bidder shall furnish the information required by the Solicitation. The bidder shall sign the Solicitation and print or type his name on the Schedule. Erasures or other changes must be initiated by the person signing the bid. Bids signed by an agent are to be accompanied by evidence of this authority unless such evidence has been previously furnished to the issuing office.
 - 2.2 Unit price for each unit offered shall be shown and such price shall include packing unless otherwise specified. A total shall be entered in the amount column of the Schedule for each item offered. In case of discrepancies between a unit price and extended price, the unit price will be presumed to be correct.
 - 2.3 Bids for supplies or services other than those specified will not be considered. Time, if stated as a number of days, means calendar days and will include Saturdays, Sundays, and holidays beginning the day after the issuance of a Notice to Proceed. Time stated ending on a Saturday, Sunday or Government of Guam legal holiday will end at the close of the next business day.
 - 2.4 No Entitlement To Preparation Costs – the bidder expressly waives any right it may have against the government for any expenses incurred in connection with the preparation of its bid.
3. **EXPLANATION TO BIDDERS:** Any explanation desired by a bidder regarding the meaning or interpretation of the Solicitation, drawings, specifications, etc., must be submitted in writing and with sufficient time allowed for a written reply to reach all bidders before the submission of their bids. Oral explanations or instructions given before the award of the contract will not be binding. Any information given to a prospective bidder concerning a Solicitation will be furnished to all prospective bidders in writing as an amendment to the Solicitation if such information would be prejudicial to informed bidders.
4. **ACKNOWLEDGEMENT OF AMENDMENTS TO SOLICITATIONS:** Receipt of an amendment to a Solicitation by a bidder must be acknowledged by signing an acknowledgement of receipt of the amendment. Such acknowledgement must be received prior to the hour and date specified for receipt of bids.
5. **BID SUBMISSIONS:**
 - a) All Bids and bid documents must be submitted in writing. Bids and modifications thereof shall be enclosed in sealed envelopes if submitting in hardcopy, and addressed to the office specified in the Solicitation. Sealed hard copy bids shall be submitted in a sealed envelope to include one (1) fully executed original and one (1) copy. The outer envelope shall be marked in bold letters, Re-bid for 180' Telescopic Boom Lift (IFB-PAG-013-24). The bidder shall show the hour and date specified in the Solicitation for receipt, the Solicitation number, and the name and address of the bidder or authorized representative on the face of the envelope if submitting in hard copy.
 - b) E-mail submissions of written bids will be accepted. PAG will accept timely electronic submission of Bids by e-mail to the single Point of Contact, Mark A. Cabrera, at ifb.pag.013.24@gmail.com before the time and date for the opening of bids. Bids electronically submitted to any other person through any other method of electronic transmission will not be accepted. If submitting a Bid by e-mail, the subject line of the e-mail transmission shall contain the Bidder's the name and the name of the Bidder's authorized representative, along with the following caption: Re-bid for 180' Telescopic Boom Lifts (IFB-PAG-013-24). Bids may be modified or withdrawn by written notice, provided such notice is

is received prior to the hour and date specified for receipt, pursuant to the Guam Procurement Rules & Regulations.

- c) Bids and Bid Documents may be signed by the Bidder electronically, and in any number of counterparts, each of which shall be deemed an original, but all of which together shall be submitted with the Bid and shall constitute the Bid. Failure to submit the required forms in the number or format required may be cause for rejection of Bids due to non-responsiveness.
- d) Samples of Items, when required, must be submitted within the time specified, unless otherwise specified by the Government, at no expense to the Government. If not destroyed by testing, samples will be returned at bidder's request and expense, unless otherwise specified by the Solicitation.
- e) Samples or descriptive literature should not be submitted unless it is required on this solicitation. Regardless of any attempt by a bidder to condition the bid, unsolicited samples or descriptive literature will not be examined or tested at the bidder's risk, and will not be deemed to vary any of the provisions of this Solicitation.

6. **FAILURE TO SUBMIT BID:** If no bid is to be submitted, do not return the solicitation unless otherwise specified. A letter or postcard shall be sent to the issuing office advising whether future Solicitations for the type of supplies or services covered by this Solicitation are desired.

7. **LATE BID, LATE WITHDRAWALS, AND LATE MODIFICATIONS:**

- a) Definition: Any bid received after the time and date set for receipt of bids is late. Any withdrawal or modification of a bid received after the time and date set for opening of bids at the place designated for opening is late (Guam Procurement Regulations 2 GAR, Div.4 §3109(k)).
- b) Treatment: No late bid, late modification, or late withdrawal will be considered unless received before contract award, and the bid, modification, or withdrawal would have been timely but for the action or inaction of territorial personnel directly serving the procurement activity.

8. **DISCOUNTS:**

- a) Notwithstanding the fact that prompt payment discounts may be offered, such offer will not be considered in evaluating bids for award unless otherwise specified in the Solicitation. However, offered discounts will be taken if payment is made within the discount period, even though not considered in the evaluation of bids.
- b) In connection with any discount offered, time will be computed from date of delivery and acceptance of the supplies to the destination as indicated in the purchase order or contract. Payment is deemed to be made for the purpose of earning the discount on the date of mailing of the Government check.

9. **GOVERNMENT FURNISHED PROPERTY:** No material, labor or facilities will be furnished by the Government unless otherwise provided for in the Solicitation.

10. **SELLER INVOICES:** Invoices shall be prepared and submitted in quadruplicate (one copy shall be marked "original") unless otherwise specified. Invoices shall be "certified true and correct" and shall contain the following information: Contract and order number (if any), item numbers, description of supplies or services, sizes, quantities, unit prices, and extended total. Bill of lading number and weight of shipment will be shown for shipments made on Government bills of lading.

11. **RECEIPT, OPENING AND RECORDING OF BIDS:** Bids and modifications shall be publicly opened in the presence of one or more witnesses, at the time, date, and place designated in the Invitation for Bids. The name of each bidder, the bid price, and such other information as is deemed appropriate by the Procurement Officer, shall be read aloud and recorded, or otherwise made available. The names and addresses of required witnesses shall be recorded at the opening. The opened bids shall be available for public inspection except to the extent the bidder designates trade secrets or other proprietary data to be confidential as set forth in accordance with Section 12, below. Material so designated shall accompany the bid and shall be readily separable from the bid in order to facilitate public inspection of the non-confidential portion of the bid. Prices, makes and models or catalogue numbers of the items offered, deliveries, and terms of payment shall be publicly available at the time of bid opening regardless of any designation to the contrary (Guam Procurement Regulations 2 GAR, Div.4 §3109(k)).

12. **CONFIDENTIAL DATA**: If a bidder considers any information submitted in its bid to be confidential, the bidder must identify in writing to the Government those portions which it considers confidential, and must request in writing that those portions be kept confidential. Only trade secrets and proprietary data will be considered confidential. If there is a request for confidentiality, the Government will render a decision on the request as soon as practicable after bids are opened. The Government will advise any bidder requesting confidentiality, of the Government's decision in writing. If the Government does not agree with a bidder's request, then the Government will inform the bidder that it may lodge a protest regarding any part of the Government's decision by following the procedure for protests outlined in Chapter 9 of the Guam Procurement Regulations.
13. **PROHIBITION AGAINST GRATUITIES AND KICKBACKS**: With respect to this procurement and any other contract that bidder may have or wish to enter into with the Government, the bidder represents that he/she has not violated, is not violating, and promises that he will not violate the prohibition against gratuities and kickbacks set forth in the Guam Procurement Regulations.
14. **STATEMENT OF QUALIFICATIONS**: The ability capacity and skill of the Bidders to perform; Whether the bidder can perform promptly or within the specified time; The quality of performance of the Bidder with regards to awards previously made to him; The sufficiency of the financial resources and ability of the bidders to perform; and the compliance with all of the conditions to the solicitation.
15. **WAGE AND BENEFIT COMPLIANCE-CONTRACTORS PROVIDING SERVICES**
- a) Contractor with regard to all person its employs whose purpose in whole or in part is the direct delivery of services contracted for with the Government of Guam in this procurement, shall pay such employees in accordance with the Wage Determination for Guam and the Northern Marianas Islands issued and promulgated by the U.S. Department of Labor for such labor as is employed in the direct deliverance of deliverables to the government of Guam. 5 GCA § 5801 Contractor shall be responsible for flowing down this obligation to its subcontractors.
 - b) The Wage Determination most recently issued by the U.S. Department of Labor at the time this Agreement was awarded to Contractor shall be used to determine wages and benefits which shall be paid to employees pursuant to this clause. 5 GCA § 5801
 - c) Should any contract contain a renewal clause, then at the time of renewal adjustments there shall be stipulations contained in that contract for applying the Wage Determination, so that the Wage Determination promulgated by the U.S Department of Labor on a date most recent to the renewal date shall apply. 5 GCA § 5801
 - d) In addition to the Wage Determination detailed above, health and similar benefits for employees having a minimum value as detailed in the Wage Determination issued and promulgated by the U.S. Department of Labor shall apply. Contractor shall pay a minimum of ten (10) paid holidays per annum per employee. 5 GCA § 5802
 - e) Any violation of Contractor or its subcontractor's obligations of this section shall be investigated by the Guam Department of Labor and may include a monetary penalty assessment by the Guam Department of Labor of no less than One Hundred Dollars (\$100.00) per day, and no more than One Thousand Dollars (\$1,000.00) per day, until such time as a violation has been corrected, as well as the payment of all back wages and benefits due. 5 GCA § 5803
 - f) In addition to any and all other breach of contract actions the Government of Guam may have under this procurement, in the event there is a violation in the process set forth in subsection (e) above, Contractor may be placed on probationary status by the GENERAL MANAGER of the General Service Agency, or its successor, for a period of one (1) year.

During the probationary status, a Contractor shall not be awarded any contract by any instrumentality of the Government of Guam. A Contractor who has been placed on probationary status, or has been assessed a monetary penalty pursuant to 5 G.C.A. Article 13 Title 5 may appeal such penalty or probationary status to the Superior Court of Guam. 5 GCA § 5804
 - g) Contractor along with all proposed Offerors and submitter under this procurement were required to submit a Declaration of Compliance with Wage Determination laws as part of this procurement

with a copy of the most recent Wage Determination for Guam and the Northern Marianas Islands issued and promulgated by the U.S. Department of Labor. 5 GCA §5805

- h) The applicable USDOL Wage Determination Rate Revision (as defined by subsections (b) and (c)) is to this Agreement. Contractor agrees to provide upon written request by the Government of Guam written certification of its compliance with its obligations as part of each invoice, along with the names of any employees, their positions, and detailed wage and benefits paid in keeping with this section. Additionally, upon request by Government of Guam the Contractor shall submit source documents as to those individuals provide direct services in part or whole under this Agreement and its payments to them of such wages and benefits.

16. **ETHICAL STANDARDS:** With respect to this procurement and any other contract that the Contractor may have, or wish to enter into, with any government of Guam agency, the Contractor represents that it has not knowingly influenced, and promises that it will not knowingly influence, any government employee to breach any of the ethical standards set forth in the Guam Procurement Law and in any of the Guam Procurement Regulations.
17. **PROHIBITION AGAINST CONTINGENT FEES:** The Contractor represents that he has not retained any person or agency upon an agreement or understanding for a percentage, commission, brokerage, or other contingent arrangement, except for retention of bona fide employees or bona fide established commercial selling agencies, to solicit or secure this Agreement or any other contract with the government of Guam or its agencies.
18. **CONTRACTOR'S WARRANTY AS TO EMPLOYEES AND SEX OFFENSES.** Reference 5 GCA 5253 (b)
Contractor warrants that no person providing services on behalf of the Contractor has been convicted of a sex offense under the provisions of Chapter 25 of Title 9 of GCA or an offense as defined in Article 2 of Chapter 28, Title 9 GCA, or an offense in another jurisdiction with, at a minimum, the same elements as such offenses, or who is listed on the Sex Offender Registry.

Contractor warrants that if any person providing services on behalf of Contractor is convicted of a sex offense under the provisions of Chapter 25 of Title 9 GCA, or an offense as defined in Article 2 of Chapter 28, Title 9 GCA, or an offense in another jurisdiction with, at a minimum, the same elements as such offenses, or who is listed on the Sex Offender Registry, that such person will be immediately removed from working at said agency and that the administrator of said agency be informed of such within twenty-four (24) hours of such conviction. Any contractor found in violation of this section, after notice from the Government of Guam, after notice from the contracting authority of such violation, shall within twenty-four (24) hours, take corrective action and shall report such action to the contracting authority. Failure to take corrective action with the stipulated period may result in the temporary suspension of the contract at the discretion of the Government of Guam.

19. **POLICY IN FAVOR OF SERVICE-DISABLED VETERAN OWNED BUSINESSES** P.L. 31-115 (September 20, 2011) 5 GCA § 5011 and § 5012 In the procurement of any supply or service, (except for professional services), if such supply or service is offered by a Service-Disabled Veteran Owned Business "SDVOB", as defined in 5 GCA § 5012, that is at least fifty one percent (51%) owned by service-disabled veteran(s), and if the supply or service is available within the period that is required for the procurement, and the price for the supply or service does not exceed one hundred five percent (105%) of the lowest bidder price, a preference shall be given to that SDVOB by the Government of Guam, and the supply or service shall be purchased from said SDVOB. This shall be in addition to any other procurement benefit the SDVOB may qualify for under Guam law. A business concern is a qualified SDVOB if: (a) the business concern is licensed to do business on Guam; (b) the business concern maintains its headquarters on Guam; (c) the business concern is at least fifty-one (51%) owned by a service-disabled veteran(s) who served in the active U.S. military service, was discharged or released under honorable conditions and whose disability is service-connected as demonstrated by a DD214, and certified by an award letter from the U.S. Department of Veterans Affairs; the DD214 and Disability award letter from U.S. Department of Veterans Affairs are submitted to the Government of Guam procuring agency for every service offered; and the service disabled veteran(s) owner(s) of the business concern has filed individual tax returns on Guam for a period of at least three (3) consecutive years.
20. **Policy In Favor of Women-Owned Businesses.** (a) Notwithstanding any other provision of law, if any entity of the government of Guam or any entity expending governmental funds intends to procure any

supply or service which is offered by a business concern that is at least fifty-one percent (51%) owned by women, that entity shall procure such supply or service from that business concern if the supply or service is available within the period required by the procuring entity and the price for the supply or service does not exceed one hundred five percent (105%) of the lowest price bidder, and shall be in addition to any other procurement benefit the women-owned business may qualify for under Guam law. The procuring entity shall determine the lowest price to the entity in the case of more than one (1) women-owned business, or a women-owned business and a service-disabled veteran owned business, who are competing for the same government contract. (b) Qualifications of a Women-Owned Business. A business concern is qualified under Subsection (a) of this Section if: (1) the business concern is licensed to do business on Guam; (2) the business concern maintains its headquarters on Guam; (3) the business concern is at least fifty-one percent (51%) owned by women, who manage day-to-day operations and make long-term decisions; (4) the business concern is certified as a Women-Owned Small Business (WOSB) or an Economically Disadvantaged Women-Owned Small Business (EDWOSB) by the U.S. Small Business Administration; and (5) the owner(s) of the business concern has (have) filed individual tax returns on Guam for a period of at least three (3) consecutive years.

ITEM NO.	DESCRIPTION	QUANTITY	UNIT	UNIT PRICE	EXTENSION
1.1	Telescopic Boom Lift, 180' Reach Full time 4WD	1	EA.	\$ 517,205.41	\$ 517,205.41

GENERAL: These specifications have been written, to describe minimum equipment and performance requirements to be supplied by the equipment manufacture bidding. Reasonable test may be conducted upon delivery before acceptance.

The successful bidder shall furnish all necessary and desirable information and instructions for the proper operation of the equipment.

The government reserves the right to accept and/or reject any and all bids, to waive any defects, irregularities, or specification discrepancies and to award the bid as council deems to be in the best interest of the government.

DISCREPANCIES

LISTED: Should any bidder have deviations from these specifications in his bid and cannot meet every requirement of the specifications, he shall submit a letter and attach it to the bid, explaining the deviations, failure to do so will cause the bid to be rejected as being non-responsive.

DELIVER: The successful bidder shall deliver one (1) 180' Boom Lift each be new fully assembled and ready for operation to the Port Authority of Guam within 120 days.

SPECIFICATIONS:

BIDDING AND OR REMARKS:

Engine:	74 hp minimum, Diesel Engine Engine shutoff protection system (Low Oil Pressure, High Engine Temperature High Transmission Temperature)	comply
Fuel Type:	Diesel (Ultra Low Sulfur) Tier IV	comply
Fuel Tank:	The fuel tank furnished shall be Min. 60 gallon	exception - 45 gallon
Platform reach:	180ft & 10ft jib	comply, 13' jib
Platform Dimensions:	36 x 96 with railing & side entry	comply
Platform Capacity:	Unrestricted - 500 lbs	comply
	Restricted - 750 lbs	comply - 1,000 pounds
Platform Rotation:	160 degrees	comply - 173 degrees
Swing:	360 degrees continuous	comply
Steering:	Selectable Steering (ground level or platform)	exception - ground control steering select not available - platform only
Axles:	Extendable front and rear	comply
Gauges:	Air, Fuel, Hour, Volt, Temp, and Oil	exception - status lights only
Lights:	2 Headlights in facing forward with protective guard, 2 Headlights facing rear with protective guard. 2 work lights on platform	exception - quoted are platform worklights, headlights, and red tail lights
Tires:	Protector Lug Foam Filled tires	comply
Manlift Accessories:	Platform to be plumbed with air lines for use of pneumatic Tools	comply
	Hostile Weather/Environment Kit	comply
	AC plug/outlet in platform	comply

Accessories: Standard manufacture accessories to include
 Horn - Electric comply
 Amber strobe light, key switch "on position" activated. comply
 Mounted 5 lbs. fire extinguisher on platform comply - 20 pound
 1 set "Shop Type" repair manuals and complete digital files available at www.jlg.com
 illustrated parts manual. hand held analyzer available from JLG parts
 Diagnostic and Troubleshooting software comply
 Owner/Operator manual for each equipment digital files available at www.jlg.com
 Maintenance and Service manual for each equipment warranty statement is attached
 Warranty booklet for each equipment included in digital parts manual
 Recommended spare parts list comply
 All fluids to the fullest level filled in accordance with shipping regulations
 Fuel tank to be loaded with 10 gallons of diesel. comply
 Electronic Backup alarm comply
 Engine shut-off protection system (Low Oil Pressure, comply
 High Engine Temperature and High Transmission comply
 Temperatures). not available
 Reflective Conspicuity Tape comply
 Electronic rust prevention system comply

Receiving Date: (Acceptance Date) will be Three (3) days after delivery Date, provided the Equipment is Delivered Completely Assembled and meets all specifications, terms and conditions of the bid requirements. comply

Special Provision: If parts catalog and maintenance repair comes in CD-ROM or Microfiche, bidder must supply to requesting agency. Bidder must still provide hard (book) copy to the requesting agency. hard copy operators manual provided digital file of other manuals available for no charge at www.jlg.com

Applicable Federal Laws And Regulations: Buy American Act – 41 U.S.C § 8301-8305 Build America Buy America Act Certificate must be provide by the manufacture. country of origin is US certificate of origin is available upon request Build America Buy America Act Certificate not available

Training: Provide 2 sessions on pre inspection, post inspection and safe operational procedures for all operators, leaders, supervisors and dispatchers within Maintenance division. not available

Warranty: Manufacturers Standard Warranty, 1 year limited warranty. Service of one (1) year/ 2,000 hours, all parts, labor and oil disposal shall be included at "No Cost to the Government".

Yes, offer as requested. standard JLG commercial warranty applies - see attached warranty statement
 No, Offer the following: oil disposal not included

The manufacturer Warranty and Boucher shall be specified on items covered and provided in the bid packet. (Bid submission received without written warranty and Boucher as specified will be rejected).

Yes, offer as requested. warranty statement is attached - requirement for "Boucher" is unclear
 No, Offer the following: _____

The successful bidder shall provide technical assistance and warranty administration without any cost to "The Port Authority of Guam"

- Yes, offer as requested. _____
- No, Offer the following: Terms and conditions of JLG standard commercial warranty apply.

The successful bidder shall provide service, such as to determine deficiency, repair or adjustment of the equipment on government premises or transfer the equipment to the shop where the repair should be done, at anytime within the warranty period and at "No cost to the Government". When the equipment is down for warranty repair(s) and remain in shop for a certain period awaiting part(s) and or material(s), the total down-time period shall be extended to the service and warranty period.

- Yes, offer as requested. _____
- No, Offer the following: Terms and conditions of JLG standard commercial warranty apply.

The manufacture shall have a local authorized dealer who can provide factory trained service technician(s). Bidder shall provide certification of factory trained technician(s) for the above equipments be purchased during commissioning. Failure to provided will result as "Unacceptable".

- Yes, offer as requested. _____
- No, Offer the following: Technical phone support is available at no charge.

Provide Complete Familiarization Training to Port Representatives on maintenance of Mechanical, Electrical and Hydraulic systems on units by manufacturer. All costs Associated with training (airfare, lodging and transportation) are to be included At no cost to the Government of Guam.

- Yes, offer as requested. _____
- No, Offer the following: Not available.

This project is funded under ther Fiscal Year 2022 America's Marine Highway (AMH) Program Grant No.: 693JF72340007

Certification requirements for procurement of steel, iron, construction materials, or manufactured products. If steel, iron, construction materials, or manufactured products (as defined in § 70914(a) of the Build America, Buy America Act, Pub. L. No. 117-58, div. G, tit. IX, subtit. A, 135 Stat. 429, 1298 (2021) and Office of Management and Budget (OMB) Memorandum M-22-11, "Initial Implementation Guidance on Application of Buy America Preference in Federal Financial Assistance Programs for Infrastructure," as implemented by MARAD through Term B.5 of the exhibits to the agreement) are being procured, the same or equivalent certificate as set forth below shall be completed and submitted by each bidder or offeror in accordance with the requirement contained in section 2.1 of the agreement

Certificate of Compliance with Buy America Requirements

The bidder or offeror hereby certifies that it will comply with the requirements of § 70914(a) of the Build America, Buy America Act, Pub. L. No. 117-58, div. G, tit. IX, subtit. A, 135 Stat. 429, 1298 (2021), as implemented by MARAD in Term B.5 of the exhibits to the grant agreement.

Date 05/07/2024
Signature _____
Company Federal Contracts Corp
Name Pete Pierson
Title Vice President

Certificate of Non-Compliance with Buy America Requirements

The bidder or offeror hereby certifies that it cannot comply with the requirements of § 70914(a) of the Build America, Buy America Act, Pub. L. No. 117-58, div. G, tit. IX, subtit. A, 135 Stat. 429, as implemented by MARAD in Term B.5 of the exhibits to the grant agreement, but it may qualify for an exception to the requirement pursuant to § 70914(b) of the Build America, Buy America Act and Term B.5.

Date 05/07/2024
Signature _____
Company Federal Contracts Corp
Name Pete Pierson
Title Vice President

Notes: Bidder shall identify on their bids, any deviations from the specifications or requirements in the remarks column and state the item being offered for evaluation processing. Failure to comply may result in the rejection of the bid.

A certificate of origin is required on the sale of equipment.

Equipment must be delivered to the Port Authority of Guam for inspection

Bidding on: Telescopic Boom Lift 180' reach, Full time 4WD

MANUFACTURER:	JLG Industries, Inc.
MAKE:	JLG
MODEL:	1850SJ
YEAR:	2024
PLACE OF ORIGIN:	USA
DATE OF DELIVERY:	150 days after receipt of order

These specifications have been developed by Port Authority of Guam's, Raymond B. Santos- Transportation Superintendent, Joaquin P. Pangalnan- Equipment Service Support Manager, reviewed by Glenn B. Nelson- Operations Manager, Dominic G. Muna- DGMO, Pacifico Martir- DGMA, and approved by Rory J. Respicio- General Manager

1850SJ

TELESCOPIC ULTRA BODY

BOOM LIFT



STANDARD SPECIFICATIONS

Performance

Platform Height	115-Ft / 35-M
Maximum Outreach	22-Ft / 6.7-M
Swing	360 Degrees (90° Power)
Platform Capacity (Standard)	1000-Lb / 454-Kg
Platform Capacity (Optional)	1000-Lb / 454-Kg
Platform Rotation	177 Degrees (179° w/ Kit)
Job Length (Retracted/Extended)	15-Ft (4.57-M) / 20-Ft (6.1-M)
Job Range of Articulation	175 Degrees (-75° - +75°)
Weight*	52900-Lb / 23970-Kg
Max. Ground Bearing Pressure	75.6 psi / 5.11 kg/cm ²
Drive Speed	2.8 mph / 4.5 km/h
Gradeability	40%
Max. Cut-Off	5 Degrees

Lifting Requirements

Asket Protection (Standard)	25-Ft 2-in (7.62-M) / 2-Ft 7-in (2.3-M)
Warning Beacon (Optional)	
Asket Protection (Standard)	25-Ft 3-in (7.62-M) / 2-Ft 3-in (6.6-M)

Engine

Direct Engine (Optional) (DIESEL) (Optional)	99.9 hp / 74.0 kW
Fuel Tank Capacity	45 gal / 171 L

Tires

Standard	22.5/24.5R26 Pneumatic
----------	------------------------

Hydraulic System

Capacity	25 gal / 95 L
----------	---------------

KEY SPEC

Platform Height 115-Ft / 35.3-M	Horizontal Outreach 22-Ft / 6.7-M
Drive Speed 2.8 mph / 4.5 km/h	Platform Capacity 1000-Lb / 454-Kg (Standard) 1000-Lb / 454-Kg (Optional)

KEY FEATURES

- Large work area of a maximum outreach height of 115-ft and a telescoping job that provides 22-ft of additional reach of work area.
- Enhanced Platform Console - An LCD screen shows operators what they see in the work envelope, along with other vital information.
- Operator awareness ability with built-in laser level allows operator to correct or adjust tilt.
- 3-1/2" wide, dual warning system features lower parts and reaches no weight to collapse.

ACCESSORIES & OPTIONS

- Auxiliary Package
- SkyMotion™ Package
- SkyPower™ Package
- SkyClear™ Package
- Activated Wheel Access System
- Roll-Over Protection System
- Cold Weather Package
- High-Visibility Package
- Lights Package
- Platform Mark (B1) On
- Mesh 1/2-In. Roll-Over Protection or Aluminum
- Mesh to Mid Rail, Pallet or Aluminum
- Platform Options
- Full Access, Rear Entry
- 36 x 36-in
- Drop Bar
- 30 x 36-in, 35 x 36-in
- New and Self-Closing Spring Gate
- 36 x 36-in, 46 x 36-in
- In-Center, Demo Bar
- 36 x 36-in, 36 x 36-in
- In-Center, Spring Gate
- 36 x 36-in, 36 x 36-in
- Wireless™ 24-hour Detection System
- Sensi-Touch System
- Storage Key, Gate or Access

STANDARD FEATURES

- HVDC Auxiliary Power
- 177 Degrees Platform Rotation
- 1-Selectable Lifting Modes
- AC Protection in Platform
- All Motion Alarm
- Curbside Smart Park™ (For 360° of Rotation)
- Control AOC™ System
- Eco-Off™ (Optional) A-List
- Engine Diagnostic Monitoring/Shutdown™ - Selectable via A.G. Analyze™
- Full-Flow 47.0
- Clean Purge
- Cool-Down Shut-Down™
- Maintenance
- LCD Monitor, Monitor for Alarm (B1) (B1) (B1)
- Lifting the Clutch Lever
- Load Sensing System
- LCD Panel 16 Operator's Platform Control Console
- Platform 36 x 36-in (31 x 24-in) Side Entry
- Platform Console Monitor (Color Light Panel)™
- Selectable Capacity Labeling
- Swing-Out Engine 5-By
- SkyClear™ B (B1)™
- 16-Light and Alarm

Standard Capacity is based on 1000-lb platform weight.
*The actual load and capacity for any application must always be determined by the user.
**Platform and lift by a Platform Control Console for Platform (Optional) for Full-Flow 47.0. Light and color "Light" is also available.
† Platform capacity will depend on the configuration and load. For more information, please refer to the lift's load chart and manual for details.
‡ Maximum lifting height, load and lift capacity are 1 to 200 ft in both directions from the center of the platform.
§ Actual lift capacity and weight available at all times must be determined by the user and the lift's load chart.

DIMENSIONS

REACH DIAGRAM

All dimensions are approximate

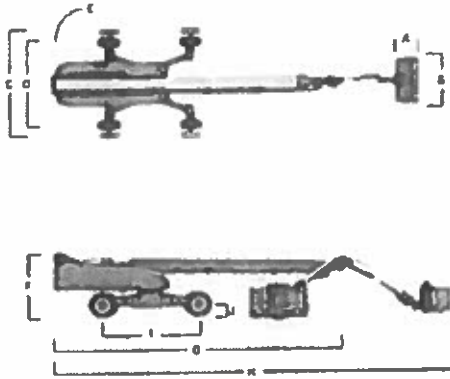

- A. Platform Width 15 in / 38 cm
- B. Platform Length 76 in / 193 cm
- C. Machine Width - Aides Extended 16 ft 6 in / 5.0 m
- D. Machine Width - Aides Retracted 8 ft 7 in / 2.6 m
- E. Tailswing 3 ft 2 in / 98 cm
- F. Machine Height 10 ft 11 in / 3.1 m
- G. Machine Length - Stowed 43 ft 9 in / 13.4 m
- H. Machine Length - Overall 63 ft 10 in / 19.5 m
- I. Wheelbase 37 ft 11 in / 11.6 m
- J. Ground Clearance 15 in / 38 cm Aisle 41 cm Chassis

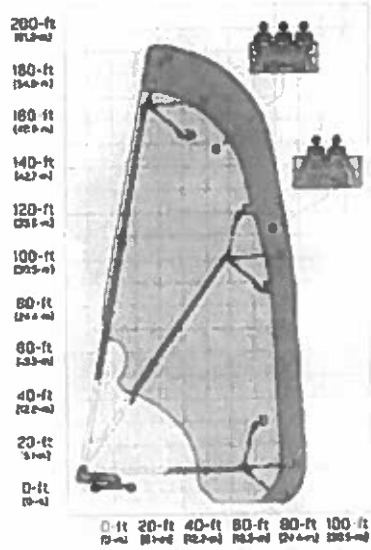

The JLG 185 coverage is one (1) full year and covers all specified major structural components for the life of the lift. Due to variations in local environmental conditions, we reserve the right to make adjustments to the warranty terms. This machine is not to be used for any purpose other than that for which it was designed. Please refer to the operator's manual for detailed safety information. Please operate the lift according to the manufacturer's instructions.

Part No. 1850SJ / 1850J06



JLG INDUSTRIES, INC.
Call Free US 1-877-475-5171
JLG.com
An Ingersoll Rand Company



12918 N. Nebraska Ave.
 Tampa, FL 33612
 UEI: TK67EL9NPM09
 Cage Code: 3VCK4
 FEIT: 42-1613127
 DUNS: 094261935

POC: Mark A. Cabrera
 TO: Port Authority of Guam

Sales Quote IFB-PAG-013-24
 Date: 5/7/2024

GSA Contract No.
 GS-03F-113DA

Phone: 671-477-5931 ext. 252
 E-Mail macabrera@portofguam.com

Certs: SDVOSB, HUBZone SB

Qty.	Manufacturer	Item No.	Description	Unit Price	Total Price
1	JLG	1850SJ	Telescopic Boom Lift	\$458,543.67	\$458,543.67
1		FREIGHT	Freight- Sales	\$38,800.00	\$38,800.00
1		FCC03	Misc Charges - 4% Tax	\$19,861.74	\$19,861.74

FOB: Destination
 Delivery Time: 365 Days ARO

JLG 1850SJ, USA ANSI 92.20, USA SPEC, DEUTZ ENGINE
 T4F (STEEL HOODS), J BOOM, 4 WHEEL DRIVE,
 IN455/50D710 FF TIRES, 4 WHEEL STEER, PLATF 36X96 SE,
 SWING GATE,LSS, *1/2" AIRLINE, FIXED AXLE,
 *PLATFORM WORKLIGHTS, *HEAD,TAIL LIGHTS PACKAGE,
 ENGLISH DECALS, SKYLINE (STD), *HOSTILE PACKAGE,
 CREAM PAINT W/ORANGE TRIM, *FIRE EXTINGUISHER (20LB)

*FREIGHT TO GUAM INCLUDED

PLEASE NOTE:

- Customer is responsible for any taxes and duties to get the unit released at the port.
- JLG does not have an authorized service center on the island of Guam.
- Any fees required to ensure aftermarket support in this region are not included in this pricing.
- Machine complies to Buy American Build Act.
- The 7,500-watt SkyPower generator is commonly ordered on this model but was not listed as a requirement, so is not Included in this pricing.
- Amber strobe is standard.
- Model is 1850SJ, Not 1850SJ/P

Subtotal: \$517,205.41
 Tax: \$0.00
Total: \$517,205.41

Pete Pierson, Vice President
 O. (813)631-0000
 F. (813)631-0008
 pete@federalcontractscorp.com



12918 N. Nebraska Ave.
Tampa, FL 33612
UEI: TK67EL9NPM9
Cage Code: 3VCK4
FEIT: 42-1613127
DUNS: 094261935

POC: Mark A. Cabrera
TO: Port Authority of Guam

Sales Quote IFB-PAG-013-24
Date: 5/7/2024

GSA Contract No.
GS-03F-113DA

Phone: 671-477-5931 ext. 252
E-Mail macabrera@portofguam.com

Certs: SDVOSB, HUBZone SB

Terms and Conditions:

- Quote valid for 30 days
- Terms: Net 30
- Unless otherwise specified, full dock or off-loading capabilities required to avoid additional charges.
- If using a purchase card, a credit card surcharge may apply.
- Certificate of Origin/MSO will not be released until payment in full has been received.

Pete Pierson, Vice President
O. (813)631-0000
F. (813)631-0008
pete@federalcontractscorp.com

1850SJ

TELESCOPIC ULTRA BOOM

BOOM LIFT

JLG



KEY SPECS

Platform Height
185-ft 7-in / 56.56-m

Drive Speed
2.8 mph / 4.5 km/h

Horizontal Outreach
80-ft / 24.38-m

Platform Capacity
1,000-lb / 454-kg - Restricted
500-lb / 227-kg - Unrestricted

KEY FEATURES

- Expansive work area of a maximum platform height of 185-ft and a telescoping job that provides 2.9 million cubic feet of work area.
- Enhanced Platform Controls - An LCD screen shows operators where they are in the work envelope, along with other useful information.
- Optimized maneuverability with full-time four-wheel drive to traverse over rough terrain.
- Single sensor load sensing system features fewer parts and requires no weight to calibrate.

ACCESSORIES & OPTIONS

- Accessory Packages:
 - SkyWelder® Package
 - SkyPower® Package
 - SkyGlazier® Package
- Additional Platform Options:
 - Fall Arrest, Rear Entry - 36 x 96-in
 - Drop Bar - 30 x 36-in, 36 x 96-in
 - Inward Self-Closing Swing Gate - 36 x 72-in, 36 x 96-in
 - Tri-Entry, Drop Bar - 36 x 72-in, 36 x 96-in
 - Tri-Entry, Swing Gate - 36 x 72-in, 36 x 96-in
 - Amber Beacon
 - Ambient White Noise Alarm
 - Bolt On Fall Arrest System
 - ClearSky™ Telematics
 - Cold Package Plus¹
 - Cold Weather Start Kit²
 - Hostile Environment Kit³
 - Light Package⁴
 - Platform Mesh, Bolt On
 - Mesh to Top Rail, Plastic or Aluminum
 - Mesh to Mid Rail, Plastic or Aluminum
 - SkySense® Enhanced Detection System
 - Soft Touch System
 - Special Hydraulic Oils
 - Platform Storage Tray, Center or Corner

STANDARD SPECIFICATIONS

Performance

Platform Height	185-ft 7-in / 56.56-m
Horizontal Outreach	80-ft / 24.38-m
Swing	360 Degrees Continuous
Platform Capacity (Restricted)	1,000-lb / 454-kg
Platform Capacity (Unrestricted)	500-lb / 227-kg
Platform Rotator	173 Degrees Hydraulic
Job Length (Retracted/Extended)	13-ft (3.96-m) / 20-ft (6.1-m)
Job Range of Articulation	120 Degrees (+75, -45)
Weight*	59,900-lb / 27,170-kg
Max. Ground Bearing Pressure	119.6 psi / 8.41 kg/cm ²
Drive Speed	2.8 mph / 4.5 km/h
Gradeability	40%
Tilt Cut Out	5 Degrees
Turning Radius (Inside)	
Axles Retracted/Extended	23-ft 4-in (7.12-m) / 7-ft 7-in (2.3-m)
Turning Radius (Outside)	
Axles Retracted/Extended	31-ft 3-in (9.52-m) / 21-ft 8-in (6.6-m)

*Includes operator or country standards, tare weight

Engine

Diesel Engine - Deutz TCD 3.6L Tier IV F	99.8 hp / 74.4 kW
Fuel Tank Capacity	45 gal / 170 L

Tires

Standard	445/50D710 Foam-filled
----------	------------------------

Hydraulic System

Capacity	75.1 gal / 284.2 L
----------	--------------------

STANDARD FEATURES

- 12V-DC Auxiliary Power
- 173 Degrees Hydraulic Platform Rotator
- 3 Selectable Steering Modes
- AC Receptacle in Platform
- All Motion Alarm
- Control ADE® System
- Drive-Out Extendable Axles
- Engine Distress Warning/Shutdown—Selectable via JLG Analyzer
- Full-Time 4WD
- Glow Plugs
- Gull-Wing Steel Hoods
- Hourmeter
- Lifting/Tie Down Lugs
- Load Sensing System
- LCD Panel at Operator's Platform Control Console
- Platform 36 x 96-in (.91 x 2.44-m) Side Entry
- Proportional Controls
- Platform Console Machine Status Light Panel¹
- Selectable Capacity Envelope
- Swing Out Engine Tray
- SkyGuard SkyLine™
- Tilt Light and Alarm

¹ Includes extreme cold engine oil, fuel conditioner, engine block heater, battery blanket, glow plugs, hydraulic tank heater, and oversized footswitch.

² Includes battery heater and oil tank heater.

³ Includes console cover, boom wipers and cylinder bellows.

⁴ Includes platform work lights, head and tail lights, amber beacon.

* Provides indicator lights at platform control console for system distress, fuel level, low fuel, 5 degree tilt light and foot switch status.

Additional accessories and options available via JLG Aftermarket.

Shown with Optional Mesh to Top Rail.

1850SJ

ULTRA BOOM

BOOM LIFT



DIMENSIONS

All dimensions are approximate

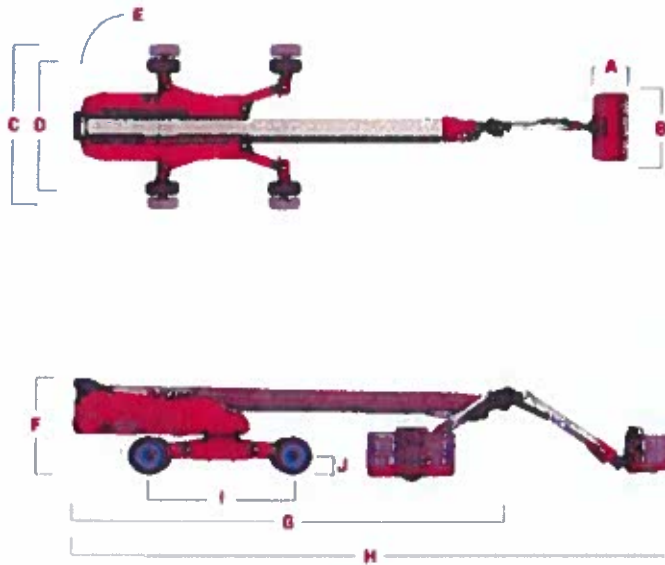

A. Platform Width	36-in / 91-cm
B. Platform Length	96-in / 2.44-m
C. Machine Width - Axles Extended	16-ft 6-in / 5-m
D. Machine Width - Axles Retracted	8-ft 2-in / 2.49-m
E. Tail'swing	7-ft 7-in / 2.32-m
F. Machine Height	10-ft / 3.05-m
G. Machine Length - Stowed	47-ft 9.5-in / 14.57-m
H. Machine Length - Overall	63-ft 10-in / 19.45-m
I. Wheelbase	17-ft 1.5-in / 5.22-m
J. Ground Clearance	13.5-in / 34-cm - Axle 16.25-in / 41-cm - Chassis

REACH DIAGRAM

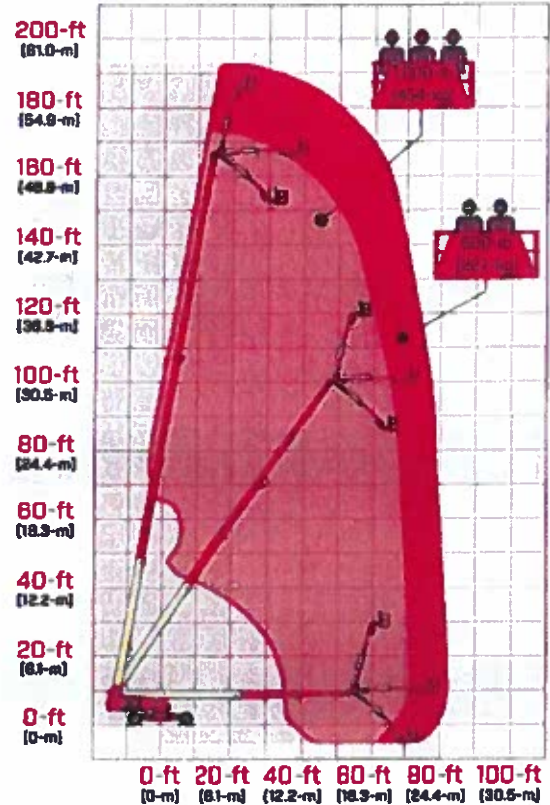

We provide coverage for one (1) full year, and cover all specified major structural components for five (5) years. Due to continuous product improvements, we reserve the right to make specification and/or equipment changes without prior notification. This machine meets or exceeds applicable ANSI and CSA requirements based on machine configuration as originally manufactured for intended applications. Please reference the serial number plate on the machine for additional information.



JLG INDUSTRIES, INC.
Toll-free US 877-JLG-LIFT
JLG.com

An Oshkosh Corporation Company

JLG NEW PRODUCT WARRANTY AMERICAS

JLG Industries, Inc. ("JLG") warrants its new products made by it to be free from defects in material or workmanship for twelve (12) months from the warranty start date.

In addition, JLG further warrants the structural elements of each new Boom Lift, Scissor Lift, Vertical Mast, Telehandler, Power Tower, Trailer, and Trailer Boom (JLG LiftPod product excluded) made by it, as defined in its then current warranty policies and procedures, to be free from defects in material or workmanship for five (5) years from the warranty start date.

JLG further warrants the powertrain of each of the new telescopic handlers made by it, as defined in its then current warranty policies and procedures, to be free from defects in material and workmanship for twenty-four (24) months or 2,000 hours, whichever occurs first.

JLG agrees only to repair or replace at its own expense, F.O.B. (E.X.W.), the place or places of manufacture, any part or parts of the product found to be defective in material or workmanship, provided JLG is notified of such defect or defects within the applicable warranty period and given a reasonable time to correct the defect. In no case shall any warranty extend to defects in materials, components, or services furnished by third parties. Defects caused by chemical action or the presence of abrasive materials and defects arising following the operation beyond rated capacity or the improper use or application of any products shall not be considered defects within the scope of this warranty. If any repairs or alterations are made or any parts are replaced during the applicable warranty periods by anyone other than JLG or an entity authorized by JLG in accordance with authorized JLG service manuals or with parts, accessories, or attachments other than authorized by JLG for use in its products, customer shall pay for such repairs or parts without recourse against JLG, and JLG shall be relieved of responsibility for fulfillment of this warranty with respect to such repairs, alterations, or replacements so made. JLG's obligations under this warranty shall at all times be subject to its then current warranty policies and procedures. The above-mentioned warranty shall not apply to replacement or service parts made and sold to a customer by JLG. Routine maintenance, routine maintenance items (including paint and decals), and minor adjustments are excluded from this warranty. Certain components, including, but not limited to, engines, tires, and batteries, which may be a part of the product are not manufactured or warranted by JLG. Any applicable warranty for such components is provided through the original manufacturer of the component or its distributor organization.

JLG further warrants that each unit is designed, built, and equipped to meet United States Environmental Protection Agency ("EPA") and, where applicable, California Air Resources Board ("CARB") emissions requirements in effect on the date of manufacture. JLG further warrants that the unit is free from defects in material and workmanship that might prevent the unit from meeting applicable EPA and CARB requirements. Policy holders may obtain such emissions warranty service at no cost, including parts, labor, and diagnostic services, for their equipment from an authorized JLG Servicer or any authorized servicer of the Engine OEM. Please also note that this Emissions Control System Warranty is required by EPA, and in certain equipment applications, by CARB, and is a distinct and additional warranty from the general commercial warranty described herein that JLG and its engine suppliers provide to customers who purchase JLG equipment and associated engines. Please refer to the "JLG Emissions Warranty Guidelines," available for download at www.JLG.com, for additional details specific to your machine. End users may also perform their own repairs of emissions-related components, although the cost of labor and diagnostic services provided by other than an authorized JLG servicer or OEM are outside the scope of this warranty and will not be paid for by JLG free of charge. The proper performance of routine maintenance by the customer or a third-party service shall not invalidate this emissions warranty.

JLG NEW PRODUCT WARRANTY NORTH AMERICA

JLG Warranty Policy covers Parts, Labor, and Travel costs as outlined in JLG's then current warranty policies and procedures. JLG LiftPod Product is excluded from Travel coverage.

JLG Warranty Policy does not cover any duties, taxes, environmental fees, including without limitation, disposal or handling of tires, batteries, and petrochemical items.

Under no circumstances shall JLG be liable for any consequential or special damages which any person or entity may incur or claim to incur as a result of any defect in the product or in any correction or alteration thereof made or furnished by JLG or others. "Consequential" or "special damage" includes, but is not limited to costs of transportation, lost sales, lost orders, lost profits, lost income, increased overhead, labor and material costs, and cost of manufacturing variances and operational inefficiencies. JLG's maximum liability under this warranty shall be the purchase price paid to JLG with respect to the product to which such warranty is claimed. The limitation of liability provisions herein shall apply to any and all claims or suits brought against JLG, including any claim based upon negligence, breach of contract, breach of warranty, strict liability or any other theories upon which liability may be asserted against JLG.

This warranty constitutes JLG's entire and exclusive warranty as to the product and is the sole and exclusive remedy for product defects in material and workmanship. JLG does not assume (and has not authorized any other person to assume on its behalf) any other warranty or liability in connection with any product covered by this warranty. **JLG EXPRESSLY DISCLAIMS ANY AND ALL OTHER WARRANTIES OF ANY KIND WHATSOEVER AS TO THE PRODUCT FURNISHED HEREUNDER, INCLUDING BUT NOT LIMITED TO ANY EXPRESS WARRANTIES, EXCEPT FOR THE EXCLUSIVE WARRANTY PROVIDED HEREIN, OR IMPLIED WARRANTIES AS TO MERCHANTABILITY, OR FITNESS FOR ANY PARTICULAR PURPOSE.**

This warranty shall be void, if, upon the occurrence of any incident involving any product made by JLG and resulting in any personal injury or property damage, customer shall fail to notify JLG within 48 hours of such occurrence or permit JLG and its representatives to have immediate access to such product and all records of or within the control of customer relating to the product and occurrence.

10c

Attachment A

Award of IFB-PAG-013-24

For Purchase for 180' Telescopic Boom Lift

Agreement Between The Port of Authority of Guam and Federal Contracts Corporation

INSTRUCTIONS FOR COMPLETION OF SF-LLL, DISCLOSURE OF LOBBYING ACTIVITIES

This disclosure form shall be completed by the reporting entity, whether sub-awardee or prime Federal recipient, at the initiation or receipt of a covered Federal action, or a material change to a previous filing, pursuant to title 31 U.S.C. section 1352. The filing of a form is required for each payment or agreement to make payment to any lobbying entity for influencing or attempting to influence an officer or employee of the Port Authority of Guam, a Member of Congress, an officer or employee of Congress, or an employee of a Member of Congress in connection with a covered Federal action. Complete all items that apply for both the initial filing and material change report. Refer to the implementing guidance published by the Office of Management and Budget for additional information.

1. Identify the type of covered Federal action for which lobbying activity is and/or has been secured to influence the outcome of a covered Federal action.
2. Identify the status of the covered Federal action.
3. Identify the appropriate classification of this report. If this is a follow-up report caused by a material change to the information previously reported, enter the year and quarter in which the change occurred. Enter the date of the last previously submitted report by this reporting entity for this covered Federal action.
4. Enter the full name, address, city, State and zip code of the reporting entity. Include Congressional District, if known. Check the appropriate classification of the reporting entity that designates if it is, or expects to be, a prime or subaward recipient. Identify the tier of the sub-awardee, e.g., the first sub-awardee of the prime is the 1st tier. Subawards include but are not limited to subcontracts, subgrants and contract awards under grants.
5. If the organization filing the report in item 4 checks "Sub-awardee," then enter the full name, address, city, State and zip code of the prime Federal recipient. Include Congressional District, if known.
6. Enter the name of the Port Authority of Guam making the award or loan commitment. Include at least one organizational level below the Port Authority of Guam name, if known. For example, Department of Transportation, United States Coast Guard.
7. Enter the Federal program name or description for the covered Federal action (item 1). If known, enter the full Catalog of Federal Domestic Assistance (CFDA) number for grants, cooperative agreements, loans, and loan commitments.
8. Enter the most appropriate Federal identifying number available for the Federal action identified in item 1 (e.g., Request for Proposal (RFP) number; Invitations for Bid (IFB) number; grant announcement number; the contract, grant, or loan award number; the application/proposal control

number assigned by the Federal Port Authority of Guam). Included prefixes, e.g., "RFP-DE-90-001."

9. For a covered Federal action where there has been an award or loan commitment by the Port Authority of Guam, enter the Federal amount of the award/loan commitment for the prime entity identified in item 4 or 5.
10. (a) Enter the full name, address, city, State and zip code of the lobbying registrant under the Lobbying Disclosure Act of 1995 engaged by the reporting entity identified in item 4 to influence the covered Federal action.

(b) Enter the full names of the individual(s) performing services, and include full address if different from 10(a). Enter Last Name, First Name, and Middle Initial (MI).
11. The certifying official shall sign and date the form, print his/her name, title, and telephone number.

According to the Paperwork Reduction Act, as amended, no persons are required to respond to a collection of information unless it displays a valid OMB control Number. The valid OMB control number for this information collection is OMB No. 0348-0046. Public reporting burden for this collection of information is estimated to average 10 minutes per response, including time for reviewing instructions, searching existing data sources, gathering and maintaining the data needed, and completing and reviewing the collection of information. Send comments regarding the burden estimate or any other aspect of this collection of information, including suggestions for reducing this burden, to the Office of Management and Budget, Paperwork Reduction Project (0348-0046), Washington, DC 20503

Approved by OMB

0348-0046

Disclosure of Lobbying Activities

Complete this form to disclose lobbying activities pursuant to 31 U.S.C. 1352

(See reverse for public burden disclosure)

<p>1. Type of Federal Action: <input checked="" type="checkbox"/> a. contract <input type="checkbox"/> b. grant c. cooperative agreement d. loan e. loan guarantee f. loan insurance</p>	<p>2. Status of Federal Action: a. bid/offer/application <input checked="" type="checkbox"/> b. initial award c. post-award</p>	<p>3. Report Type: a. initial filing <input type="checkbox"/> b. material change For material change only: Year _____ quarter _____ Date of last report _____</p>
<p>4. Name and Address of Reporting Entity: <input checked="" type="checkbox"/> Prime <input type="checkbox"/> Sub-awardee Tier _____, if Known: Federal Contracts Corp 12918 N. Nebraska Ave Tampa, FL 33612 Congressional District, if known:</p>	<p>5. If Reporting Entity in No. 4 is Sub-awardee, Enter Name and Address of Prime: Congressional District, if known:</p>	
<p>6. Federal Department/Port Authority of Guam: Port Authority of Guam</p>	<p>7. Federal Program Name/Description: CFDA Number, if applicable: _____</p>	
<p>8. Federal Action Number, if known:</p>	<p>9. Award Amount, if known: \$</p>	

<p>10. a. Name and Address of Lobbying Registrant (if individual, last name, first name, MI):</p>	<p>b. Individuals Performing Services (including address if different from No. 10a) (last name, first name, MI):</p>
<p>11. Information requested through this form is authorized by title 31 U.S.C. section 1352. This disclosure of lobbying activities is a material representation of fact upon which reliance was placed by the tier above when this transaction was made or entered into. This disclosure is required pursuant to 31 U.S.C. 1352. This information will be reported to the Congress semi-annually and will be available for public inspection. Any person who fails to file the required disclosure shall be subject to a civil penalty of not less than \$10,000 and not more than \$100,000 for each such failure.</p>	<p>Signature: <u>Pete Pierson</u></p> <p>Print Name: <u>Pete Pierson</u></p> <p>Title: <u>Vice President</u></p> <p>Telephone No.: <u>813.631.0000</u> Date: <u>06/06/2024</u></p>
<p>Federal Use Only</p>	<p>Authorized for Local Reproduction Standard Form - LLL (Rev. 7-97)</p>

Section XVI. CONFLICT OF INTEREST GUIDELINES

Offerors shall follow these Conflict of Interest (COI) Guidelines when submitting any Proposal in response to a federally funded Port Authority of Guam solicitation or procurement or when entering into any federally funded Contract with Port Authority of Guam. The Contractor shall follow these COI Guidelines throughout the period during which the Proposal/Bid is open or the Contract is in effect. An Offeror shall provide the COI Guidelines and associated COI Disclosure Form to all of its Subconsultants and Subcontractors at any tier of a Proposal or Contract and shall ensure that the Offeror and each of its Subconsultants or Subcontractors make any disclosures required by these guidelines or as required by a specific Procurement or Contract. The Port Authority of Guam will follow and apply these COI Guidelines when conducting Port Authority of Guam procurements.

1. Definitions.

The definitions that apply to these COI Guidelines and the Port Authority of Guam's COI Disclosure Form are at the end of this document.

2. Required Disclosures.

Submittal of a Correct and signed COI Disclosure Form is required if any of the following apply (note that for the purposes of these COI Guidelines "Public Employee" includes all Port Authority of Guam employees):

- an Offeror or any of its Associates have any Apparent, Potential, or Actual Conflicts of Interest per these COI guidelines or per the criteria of any COI Form included as part of a Procurement or Contract;
- a Procurement or Contract document specifically requires submittal of a COI Disclosure Form (e.g., if the prospective Project includes preparation of an Environmental Impact Statement or Environmental Assessment, submittal of COI Disclosure Forms is always required.);
- an Offeror has any changes to its staffing or organization (whether before or after entering into a Contract) that result in an Apparent, Potential or Actual Conflict of Interest per these guidelines or per the criteria of any COI form associated with a particular Procurement or Contract. Any such changes shall be disclosed within 10 business days via submittal of a complete and signed COI Disclosure Form.
- the response to any of the following questions is "yes" (with respect to a Procurement or current Contract with Port Authority of Guam):
 1. Is any Associate of the Offeror a former employee of Port Authority of Guam (within the last year)?
 2. Is any Associate of the Offeror a Relative, Immediate Family Member, or Member of the Household of a current employee of Port Authority of Guam who had or may have

a role in this Procurement, Authorization of the Contract, Contract administration, or oversight of the Contractor's performance?

3. Does the Offeror or any Associate of the Offeror have an Actual, Apparent or Potential Conflict of Interest ("Individual" or "Organizational") with regard to any member of an Port Authority of Guam Procurement evaluation or selection team?

4. Did the Offeror or any Associate of the Offeror conduct prior work on the Project described in the Procurement, or participate in preparing any part of the Procurement or any documents or reports related to the Procurement or to which the Procurement refers?

5. Does the Offeror or any Associate of the Offeror have any past, present or currently planned interests which are an Actual, Apparent, or Potential Conflict of Interest ("Individual" or "Organizational") with respect to performing the work for Port Authority of Guam?

6. Has the Offeror or an Associate of the Offeror offered to a Public Employee, or is the Offeror aware of any Public Employee that has solicited or received, directly or indirectly, any pledge or promise of employment or other benefit based on the understanding that the Public Employee's vote, official action or judgment would be influenced thereby?

7. Has (or will) the Offeror or an Associate of the Offeror provided a direct beneficial financial interest to any person within one year after the person ceased to hold a position as a Public Employee who was involved in the Procurement or Authorization for the Contract, or is the Offeror aware of any such person or Public Employee who has or will receive a direct beneficial financial interest within the one-year period?

8. Is the Offeror aware of any current or former Public Employee that has an Actual, Apparent, or Potential Conflict of Interest with respect to the Procurement or award of this Contract or performing the work for Port Authority of Guam?

9. Does the prospective Contract include development of an environmental assessment (EA) or environmental impact statement (EIS)?

10. If a Procurement is to obtain personal services for the purpose of administering, managing, monitoring, inspecting, evaluating compliance with or otherwise overseeing a public contract, is the Offeror or an Associate or an Affiliate of the Offeror a party to the subject public contract?

11. Has the Offeror or any Associate of the Offeror entered into any contract(s) with Port Authority of Guam for the purpose of advising or assisting in developing any part of the solicitation documents, including specifications, requirements, a scope or statement of work, an invitation to bid, a request for proposals or other documents and materials used in, or related to this procurement?

If none of the foregoing apply, an Offeror shall provide a written and signed certification (specified by Port Authority of Guam) that the Offeror has read and complied with these COI Guidelines and the COI Disclosure Form and did not answer Yes to any of the questions, or, if

required by the Port Authority of Guam, the Offeror shall complete and submit a Correct and signed COI Disclosure Form.

An Offeror shall incorporate in each required COI Disclosure Form any COI disclosure information provided by its staff and attach COI Disclosure Forms from each of its Subcontractors (that have required disclosures of conflicts or potential conflicts of interest), prior to such Offeror performing any services under a Contract.

The COI Disclosure Form is attached to the solicitation as a mandatory form that must be signed and submitted with Offeror's Proposal.

3. Governing Standards.

Both Guam and federal laws govern disclosure and management of conflicts of interest in contracting processes. The disclosure requirements of these COI Guidelines apply to all Port Authority of Guam contracting activities {Architectural and Engineering (A&E) and non-A&E, public improvements, goods, and trade services} without regard to which particular federal or Guam laws govern the activity. There are also Standards of Conduct Policies for conflicts of interest regarding current Port Authority of Guam employees, and the employment of former Port Authority of Guam employees, which are applicable to this procurement, and are explained below.

Standards of Conduct Policy Regarding Former Port Authority of Guam Employees

When employees of firms which compete for or have Contracts with the Port Authority of Guam come to work for the Port Authority of Guam, and when Port Authority of Guam employees go to work for firms which compete for or have Contracts with the Port Authority of Guam, a Potential Conflict of Interest may exist.

Use of a former Port Authority of Guam employee by an Offeror on the same, or substantially similar Procurement, for which the employee performed a role or function for the Port Authority of Guam, unless mitigated to the satisfaction of the Port Authority of Guam, is prohibited for a period of one year following separation of employment with the Port Authority of Guam. Roles and functions of particular concern include drafting specifications or statements of work, reviewing or scoring a bid or proposal, authorizing service or assigning work, awarding a Contract, administering a Contract, or overseeing Contractor's performance. The Port Authority of Guam may determine that the role or Procurement is not substantially similar because of differences in location of the Project or work, because of the type and method of Procurement, because the employee did not participate personally or substantially in the procurement, because the role performed was minor in nature, such as a technical sufficiency review, or because the Civil Service Commission has granted the employee an applicable waiver. Examples of mitigation that may, in appropriate situations, be acceptable to the Port Authority of Guam include separation of certain decision-making functions concerning the Project, not using the employee in preparation of proposals but allowing them to perform work on the Project, and not having the employee have direct contact with Port Authority of Guam staff formerly under his/her supervision.

For each Procurement, Offerors shall disclose to Port Authority of Guam the identification of any of Offeror's employee(s) that had been employed by Port Authority of Guam within the twelve-month period prior to the submission date for the Proposal or bid. Each Offeror's disclosure shall include a signed statement by the former Port Authority of Guam employee of their proposed role for the Offeror in the particular Procurement and any resulting Contract. Failure of an Offeror to disclose such relationship or to remedy such potential violation will result in the rejection of the Offeror's bid or cancellation of the Contract with the Port Authority of Guam as well as being grounds for cancellation of an Offeror's prequalification or designation of an Offeror as ineligible for future Procurements as not being a responsible bidder. (Also see below regarding the ban on any direct beneficial or financial interest.)

Standards of Conduct Regarding Current Port Authority of Guam Employees Conflicts of Interest

The Guam Procurement Law statutory and regulatory framework, as generally applied, addresses conflicts of interest in public contracting by emphasizing the need for open and impartial Procurement methods and by prohibiting certain conflicts of interest involving public officials. The following statutes and administrative rules establish Guam's general policies and the restrictions and prohibitions regarding conflicts of interest for public contracts and Public Employees:

- The policies of the Guam Procurement Law (5 GCA § 5001, et seq) encourage public contracting competition that supports openness and impartiality to the maximum extent possible, while recognizing that the nature of effective and meaningful competition depends upon the service being procured.
- According to 5 GCA §§ 5001(b), 5003, and 5625, a sound and responsive public contracting system should instill public confidence through ethical and fair dealing, honesty, and good faith on the part of government officials and those who do business with the government.
- Article 11 of the Guam Procurement Law, Ethics in Public Contracting, and Article 2 of the Standards of Conduct for Elected Officers, Appointed Officers and Public Employees of the Government of Guam prohibit conflicts of interest of Public Employees and prohibit Public Employees from obtaining outside financial benefits for the exercise of their official duties. Among the prohibitions are offering a public employee a fee, a pledge of future employment, or anything valued in excess of \$200 based on an understanding that the offer would influence the public employee's official action or judgment.
- 5 GCA § 5632(a) provides the following: "Contemporaneous Employment Prohibited. Except as may be permitted by regulations pursuant to this Chapter or pursuant to Title 4 GCA, or rulings of the Civil Service Commission pursuant to this Chapter, it shall be a breach of ethical standards for any employee who is participating directly or indirectly in the procurement process to become or be, while such an employee, the employee of any person contracting with the governmental body by whom the employee is employed. Notice of this provision shall be provided in accordance with regulations promulgated by the Civil Service Commission."
- 5 GCA § 5632(c) and (d) provide the following: "(c) Disqualification of Business When an Employee Has a Financial Interest. It shall be a breach of ethical standards for a business in which

an employee has a financial interest knowingly to act as a principal, or as an agent for anyone other than the Territory, in connection with any:

- (1) judicial or other proceeding, application, request for a ruling or other determination;
- (2) contract;
- (3) claim; or

(4) charge or controversy; in which the employee either participates personally and substantially through decision, approval, disapproval, recommendation, the rendering of advice, investigation or otherwise, or which is the subject of the employee's official responsibility, where the Territory is a party or has a direct and substantial interest.

(d) Selling to the Territory After Termination of Employment is Prohibited. It shall be a breach of ethical standards for any former employee, unless the former employee's last annual salary did not exceed Twelve Thousand Dollars (\$12,000.00), to engage in selling or attempting to sell supplies, services other than personal services, or construction to the Territory for ninety (90) days following the date employment ceased.

The term sell as used herein means signing a bid, proposal, or contract; negotiating a contract, contracting any employee for the purpose of obtaining, negotiating or discussing changes in specifications, price, cost allowances or other terms of a contract; settling disputes concerning performance of a contract; or any other liaison activity with a view toward the ultimate consummation of a sale although the actual contract therefor is subsequently negotiated by another person; provided, however, that this Section is not intended to preclude a former employee from accepting employment with private industry solely because the former employee's employer is a contractor with this Territory, nor shall a former employee be precluded from serving as a consultant to this Territory."

- 4 GCA § 15201 states: "No employee shall solicit, accept, or receive, directly or indirectly, any gift valued singly or in the aggregate from a single source in excess of \$200, whether in the form of money, prize, service, loan, travel, entertainment, hospitality, thing or promise, or in any other form, when a reasonable person would infer that the gift is intended to influence the employee in the performance of that individual's official duties or is intended as a reward for any official action on that individual's part."

- 4 GCA § 15204 (a), (b), (c), and (d) provide: "No employee shall use or attempt to use an official position to secure or grant unwarranted privileges, exemptions, advantages, contracts, or treatment, for himself or herself, a spouse, children, or others, including but not limited to the following:

(a) seeking other employment or contract for services by the use or attempted use of the individual's office or position;

(b) accepting, receiving, or soliciting compensation for the performance of official duties or responsibilities except as provided by law;

(c) using government time, equipment, or other facilities for private business purposes;

(d) soliciting, selling, or otherwise engaging in a financial transaction with a subordinate or a person or business whom the employee inspects or supervises in official capacity.”

- 4 GCA § 15205 (a), (b), (c), (d), and (e) provide: “Conflicts of Interest.

(a) No employee shall take any official action directly affecting:

(1) business or other undertaking in which the employee has a financial interest; or

(2) private undertaking in which the employee is engaged as legal counsel, advisor, consultant, representative, or other agency capacity. A department head who is unable to be disqualified on any matter described in item (1) or (2) of this Subsection may be in violation of this Subsection even if the individual has complied with the disclosure requirements of § 15208; and a person whose position on a board, commission or committee is mandated by statute, resolution or executive order to have particular qualifications shall only be prohibited from taking official action that directly and specifically affects a business or undertaking in which such person has a financial interest; provided that the financial interest is related to the member's particular qualifications.

(b) No employee shall acquire financial interests in any business or other undertaking which the employee has reason to believe may be directly involved in official action to be taken by the employee.

(c) No employee shall assist any person or business or act in a representative capacity before any territorial agency for any compensation in any transaction involving the Territory.

(d) No employee shall assist any person or business or act in a representative capacity for a fee or other compensation to secure passage of a bill or to obtain a contract, claim, or other transaction or proposal in which the employee has participated or will participate as an employee, nor shall the employee assist any person, or business, or act in a representative capacity for a fee or other compensation on such bill, contract, claim, or other transaction or proposal before the Legislature or territorial agency of which the individual is an employee.

(e) No employee shall assist any person or business or act in a representative capacity before a territorial agency for a fee or other compensation, on any bill, contract, claim, or other transaction or proposal involving official action by the agency if the employee has official authority over that agency unless such employee has complied with the disclosure requirements of § 15208.”

- 4 GCA § 15206 states: “Contracts.

(a) A territorial agency shall not enter into any contract with an employee or with a business in which an employee has a controlling interest, unless the contract has been awarded through an open, public process. A territorial agency may, however, enter into such contract without resort to competitive bidding process when, in the opinion of the General Services Agency or the procurement officer of that branch of government, the property or services does not fall within the purview of competitive bidding; provided that written justification for the non-competitive award of such contract be made a matter of public record and shall be filed with the Guam Ethics Commission at least ten (10) days before such contract is entered into. With regards to members of boards, commissions, and committees, this Subsection shall apply only to contracts entered

into between a business in which a member has a controlling interest and a territorial agency in which the board, commission, or committee to which the individual is appointed has jurisdiction.

(b) A territorial agency shall not enter into a contract with any person or business which is represented or assisted in a material manner in the matter by a person who has been an employee of that agency within the preceding twelve (12) months and who participated while in 8 territorial office or employment in a material manner in the matter with which the contract is directly concerned."

Port Authority of Guam's COI Guidelines embody the intent of encouraging competition through openness, impartiality, and public disclosure of relevant information (and the avoidance of conflicts of interest) as described in Guam's Procurement Law, Title 5, Chapter 5, Article 11, Ethics in Public Contracting; Title 4, Chapter 15, Standards of Conduct for Elected Officials, Appointed Officers, and Public Employees of the Government of Guam, The Guam Department of Administration Personnel Code of Conduct and Port Authority of Guam's Standards of Conduct Policies or any other applicable governmental ethics policies.

The one-year prohibition against a Public Employee having a direct beneficial financial interest in a public contract as provided in 5 GCA § 5632(b) would generally preclude the person from working under the public contract and from representing the Offeror in dealings with the public agency for whom the person had worked. Sharing in the general profits of the Offeror (such as a year-end bonus for overall corporate profits) is likely not a direct beneficial financial interest, however, a bonus or other compensation paid just on the basis of the public contract would be subject to the prohibition.

Standards of Conduct for Offerors and Contractors, and Organizational Conflicts of Interest Policy

It is the policy of Port Authority of Guam to avoid, neutralize, or mitigate organizational conflicts of interest that might exist for all procurements. Each individual contracting situation shall be examined on the basis of its particular facts and the nature of the proposed contract. The exercise of common sense, good judgment, and sound discretion is required in both the decision on whether a significant potential conflict exists and, if it does, the development of an appropriate means for resolving it. The principles underlying this policy are: (1) preventing the existence of conflicting roles that might bias an Offeror's judgment; and (2) Preventing unfair competitive advantage. In addition to the other situations described in these COI Guidelines, an unfair competitive advantage exists where an Offeror competing for award of any Port Authority of Guam contract possesses: (1) proprietary information that was obtained from a Public Employee without proper authorization; or (2) source selection information that is relevant to the contract but is not available to all competitors, and such information would assist that Offeror in obtaining the contract.

The following situations constitute organizational conflicts of interest. This listing is not exhaustive:

- A conflict of interest exists when an Offeror that provides systems engineering and technical direction for a system is awarded a contract to supply the system or any of its major components; or is a subcontractor

or consultant to a supplier of the system or any of its major components; even if the Offeror did not have overall contractual responsibility for the system's development, its integration, assembly, and checkout, or its production. In this example, systems engineering includes a combination of substantially all of the following activities: determining specifications, identifying and resolving interface problems, developing test requirements, evaluating test data, and supervising design. Technical direction includes a combination of substantially all of the following activities: developing work statements, determining parameters, directing other contractors' operations, and resolving technical controversies. In performing these activities, a contractor occupies a highly influential and responsible position in determining a system's basic concepts and supervising their execution by other contractors. Therefore, this Offeror should not be in a position to make decisions favoring its own products or capabilities.

- A conflict of interest exists when an Offeror prepares and furnishes complete specifications covering non-developmental items, to be used in a competitive procurement, and submits a proposal or bid to be allowed to furnish these items, either as a prime contractor or as a subcontractor, for a reasonable period of time including, at least, the duration of the initial production contract.
- If a single contractor drafts complete specifications for non-developmental equipment, that contractor should be eliminated for a reasonable time from competition for production based on the specifications. This should be done in order to avoid a situation in which the contractor could draft specifications favoring its own products or capabilities. In this way the Government can be assured of getting unbiased advice as to the content of the specifications and can avoid allegations of favoritism in the award of production contracts.
- When an Offeror prepares, or assists in preparing, a statement of work, scope of services, or technical specifications to be used in competitively acquiring a system or services, or provides material leading directly, predictably, and without delay to such a statement of work, scope of services, or technical specifications, it is a conflict of interest if that Offeror submits a Proposal or bid to supply the system, major components of the system, or the services, unless:
 - (i) It is the sole source;
 - (ii) It has participated in the development and design work; or
 - (iii) More than one contractor has been involved in preparing the statement of work, scope of services, or technical specifications.
- Agencies should normally prepare their own statements of work, and scopes of services. When contractor assistance is necessary to prepare the statement of work or scope of services, the contractor is in a position to favor its own products or capabilities. To overcome the possibility of bias, Offerors are prohibited from supplying a system or services acquired on the basis of a statement of work or scope of services growing out of their services, unless:
 - (i) It is the sole source;
 - (ii) It has participated in the development and design work; or
 - (iii) More than one contractor has been involved in preparing the statement of work, scope of services, or technical specifications.
- It is a conflict of interest for a contractor to participate in the evaluation of products or services that it offers. Contracts for the evaluation of offers for products or services shall not be awarded to an Offeror that will evaluate its own offers for products or services, or those of a competitor.

The following situations are not considered to constitute organizational conflicts of interest. This list is not exhaustive:

- In development work, it is normal to select firms that have done the most advanced work in the field. These firms can be expected to design and develop around their own prior knowledge. Development contractors can frequently start production earlier and more knowledgeably than firms that did not participate in the development, and this can affect the time and quality of production, both of which are important to the Government. In many instances the Government may have financed the development. Thus, while the development contractor has a competitive advantage, it is an unavoidable one that is not considered unfair; hence this is not considered an organizational conflict of interest.
- It is not an organizational conflict of interest for Offerors that furnish, at Government request, specifications or data regarding a product they provide, even though the specifications or data may have been paid for separately or in the price of the product.
- It is not an organizational conflict of interest where Offerors, acting as industry representatives, help Government agencies prepare, refine, or coordinate specifications, regardless of source, provided this assistance is supervised and controlled by Government representatives.

It is further the policy of Port Authority of Guam to restrict Offeror's use of confidential or proprietary information obtained from previous affiliations with the Port Authority of Guam or the Government when competing for Port Authority of Guam contracts. When a contractor requires proprietary information to perform a Government contract and can use the leverage of the contract to obtain it, the contractor may gain an unfair competitive advantage unless restrictions are imposed. These restrictions protect the information and encourage companies to provide it when necessary for contract performance. They are not intended to protect information: (1) furnished voluntarily without limitations on its use; or (2) available to the Government or contractor from other sources without restriction.

In addition, a contractor that gains access to proprietary information of other companies in performing advisory and assistance services for the Government must agree with the other companies to protect their information from unauthorized use or disclosure for as long as it remains proprietary and refrain from using the information for any purpose other than that for which it was furnished. The Offeror shall provide Port Authority of Guam with copies of these agreements and ensure that they are properly executed.

Contractors also obtain proprietary and source selection information by acquiring the services of marketing consultants which, if used in connection with an acquisition, may give the contractor an unfair competitive advantage. Contractors should make inquiries of marketing consultants to ensure that the marketing consultant has provided no unfair competitive advantage, and must disclose these relationships to Port Authority of Guam on the COI Disclosure Form.

Specific Federal Standards—Procurements Related to Design-Build and Design-Bid-Build

Pursuant to 23 USC § 112(b)(3), the FHWA has promulgated administrative rules that affect federally funded Design-Build procurements and related procurements. These rules, which are in Chapter 23 of the CFR Part 636, are used as the basis for Port Authority of Guam's guidelines on the subject and specifically regulate both Organizational and Individual Conflicts of Interest. Port Authority of Guam's COI Guidelines incorporate a number of concepts from these federal provisions.

The primary rule governing Organizational Conflicts of Interest in Design-Build transactions is 23 CFR § 636.116. This rule affects not only Design-Build procurements, but also "any contract for engineering services, inspection or technical support in the administration of the Design-Build contract." Following is a summary of this federal

rule (Port Authority of Guam's COI Guidelines apply this rule to design-bid-build and non-A&E activities as well):

Generally, a consultant who assists the state in preparing a Request for Proposals (RFP) document may not, subsequently, propose in response to the RFP. However, the state may determine that the consultant does not have a conflict of interest for a subsequent Procurement, if the consultant furnished only "low-level" documents that were incorporated into the RFP and made available to all offerors, and did not assist the state in the development of instructions to offerors or evaluation criteria for the RFP. These Design-Build regulations also apply to "improper business practices and personal conflicts of interest" of the Port Authority of Guam's selection team members. 23 CFR § 636.117 indicates that Federal Acquisition Regulations ("FARs"--- specifically 48 CFR Part 3, Improper Business Practices and Personal Conflicts of Interest) will apply to the state's selection team members in the absence of relevant state laws and procedures. These regulations require government business to be "above reproach," conducted "with complete impartiality and with preferential treatment for none" and with "the highest degree of public trust and an impeccable standard of conduct" to avoid "even the appearance of a conflict of interest." In design-bid-build transactions, where engineering services are procured separately from the construction services, ordinarily the consulting Offeror providing the engineering services is not eligible to bid on the construction work for the Project.

No Offeror or any Associate of an Offeror in connection with a Transportation Project shall have, directly or indirectly, any interest, other than his employment or retention by a State or other governmental instrumentality, in any Contract in connection with such Project. No firm or an Associate of an Offeror shall have, directly or indirectly, any interest in any real property acquired or to be acquired for a Project unless such interest is openly disclosed upon the records of Port Authority of Guam and such Offeror or Associate has not participated and will not participate in such acquisition for and in behalf of Port Authority of Guam (see 23 CFR § 1.33).

Specific Federal Standards - National Environmental Policy Act (NEPA)

No Offeror preparing or providing environmental analysis or impact documents relating to a Project, including draft and final Environmental Assessments (EA) or Environmental Impact Statements (EIS) may have a financial or other interest in the outcome of the Project. A financial or other interest in the outcome of the Project includes any known benefits other than general enhancement of professional reputation, and includes any agreement, enforceable promise, guarantee or expectation of future work on the Project as well as any indirect benefit the Offeror is aware of such as if the Project would aid proposals sponsored by the Offeror's other clients. Compliance with 40 C.F.R. 1506.5(c) is required, which includes the requirement for a conflict of interest disclosure statement from each Offeror establishing that the Offeror does not have a financial or other interest in the Project.

4. COI Considerations Related to Previous Work on Projects.

No Offeror that has previously performed services on behalf of Port Authority of Guam for a Project may be a Proposer or participate as an equity owner, team member, Subcontractor of or to a Proposer on the Project, or have a financial interest in any of the foregoing entities with respect to the Project, unless Port Authority of Guam is satisfied in its sole discretion that:

- (a) such services were completed prior to initiation of the Procurement for the Project (exceptions may apply for NEPA services on a case-by-case evaluation of the project specifics against the applicable CFRs);
- (b) such services included only Low-Level Documents and did not include development of instructions to offerors or evaluation criteria for the RFP;
- (c) such services did not provide the Offeror with access to or knowledge of Port Authority of Guam confidential or inside information that could provide an unfair competitive advantage with respect to the Procurement;
- (d) the prior Contract and information provided to the Offeror in the performance of its services are either irrelevant to the Procurement or are available on an equal and timely basis to all Proposers;

(e) the work product from the Offeror incorporated into or relevant to the Procurement is available through Public Disclosure on an equal and timely basis to all Proposers; and

(f) any environmental documents prepared by the Offeror have been determined to be objective, and that the Port Authority of Guam demonstrated independent decision-making authority during the environmental process.

In such instances where Port Authority of Guam is satisfied in the manner described above, Port Authority of Guam may still, in its sole discretion, restrict the scope of Procurement services for which the Offeror shall be eligible to perform in order to further the intent and goals of these COI Guidelines.

Public Disclosure of services or products is an important consideration in determining if an Organizational Conflict of Interest exists. All COI Disclosure Forms will be considered public records, as permitted under Guam's Procurement Law.

5. COI Disclosure Process.

An Offeror shall certify its compliance with these COI Guidelines at the time of submitting a Proposal to Port Authority of Guam, during the Procurement Process, and during the time of performance of any awarded Contract with Port Authority of Guam. If submittal of COI Disclosure Form(s) is required per these COI Guidelines or a specific Procurement or Contract, an Offeror shall represent the correctness of a completed COI Disclosure Form. If an Offeror has any changes to its staffing or organization (whether before or after entering a Contract) that result in an Actual, Apparent or Potential Conflict of Interest (Individual or Organizational) per these COI Guidelines or per the criteria of any COI form associated with a particular Procurement or Contract, any such changes shall be disclosed within ten (10) business days via submittal of a Correct and signed COI Disclosure Form.

An Offeror shall assure that any COI Disclosure Form it submits includes any information required to be disclosed by its Subcontractors and other Associates, on behalf of the Offeror. An Offeror may submit either the Subcontractors' separate COI Disclosure Forms or incorporate Subcontractor information into its own COI Disclosure Form. The disclosure required with the proposal applies the prime and all proposed Subcontractors that are identified or anticipated at the time of proposal submission.

The identification, assessment, and management of Actual or Potential Conflicts of Interest are joint tasks among Port Authority of Guam, the Offeror and the Offeror's team. An Offeror must work together with Port Authority of Guam in an atmosphere of candor and accountability during the period of negotiation or performance of the Contract with Port Authority of Guam. Port Authority of Guam makes the final determination as to the adequacy of any COI disclosures or COI management plan offered by the Offeror.

Port Authority of Guam's COI determination is based on a number of factors such as:

- ✓ Situational Facts – description of the situation and all known facts specific to the actual or perceived COI
- ✓ Type of Work - specific product or service and Contract(s) involved
- ✓ Relationship to Management - specific interactions with Port Authority of Guam decision-makers
- ✓ Public Disclosure - timing and availability of product or service

The specific facts disclosed in any COI situation will be unique to that situation. Therefore, the decisions and conclusions reached in one situation may or may not be directly applicable to another. For example, the definition of "low-level" documents does not isolate an Offeror producing such documents from a potential COI situation. The ultimate determination will take into account the other factors described above.

6. Examples of Conflict of Interest Situations.

Port Authority of Guam offers the following examples to better illustrate conflict of interest situations that may arise during the course of the performance of a Personal Services Contract, Purchase Request, Purchase Order, or any Contract entered into between Port Authority of Guam and an Offeror, or during any Government of

Guam Procurement process, in order to provide guidance to Offerors as they determine if their specific situations warrant disclosure, evaluation, and management.

1. A Design-Build solicitation requires the responding teams to propose how to manage site features that were uncovered by a geotechnical engineering Offeror. The Offeror's reports to Port Authority of Guam on the Project are available to the public. A multi-specialty engineering Offeror that is the parent company of the geotechnical engineering Offeror submits a proposal to design the overall Project. Depending on the particular mitigating facts, Port Authority of Guam might determine in writing that the multi-specialty engineering Offeror is eligible to propose.
2. Port Authority of Guam seeks comprehensive project management services for a series of Transportation Projects. One of the proposing Offerors employed a senior official from Port Authority of Guam who played a significant role in providing direction for the solicitation, six months ago. Port Authority of Guam initially assesses this situation as a potential Organizational Conflict of Interest and provides information to potential Proposers of this assessment through an addendum to the RFP. In its proposal, the Proposer provides mitigating information and written assurances that this individual works in an area of the company that will not be working on their program management proposal and that the individual will be isolated inside the company from any information associated with the program, will not be lobbying Port Authority of Guam, will not engage in any activities that would violate the Port Authority of Guam Code of Conduct Policy for the prescribed one-year period, and for a period of one year will not have a direct beneficial interest in the contract. Depending on the particular facts, Port Authority of Guam might determine that, while the proposing Offeror has a potential Organizational Conflict of Interest, that conflict has been adequately mitigated and the Offeror will not be disqualified from submitting a proposal.
3. Port Authority of Guam issues an RFP for design and oversight of an intelligent system to collect bridge tolls. The RFP provides that companies having a financial interest in the relevant telecommunications hardware will be excluded from bidding. A company under common ownership with a major electronics manufacturer desires to bid. Port Authority of Guam initially assesses this situation as an Organizational Conflict of Interest, because it cannot know in advance whether the hardware products of this electronics manufacturer would be used in the Project, and Port Authority of Guam informs potential Proposers of its concern related to this type of conflict via addendum to the RFP. In its proposal, the company offers no mitigating facts or organizational plans that address Port Authority of Guam's concerns about the conflict. Depending on the particular facts, Port Authority of Guam determines that the company has an actual conflict of interest.
4. Port Authority of Guam seeks advice of an industry advisory committee to formulate the specifications for an information technology (IT) RFP. An IT Offeror that participated in the advisory committee wishes to submit a proposal in response to the RFP. Depending on the particular facts, Port Authority of Guam might determine that the role of the Offeror was to represent the industry in the context of a public meeting where other Offerors were invited to submit comments, and that the Offeror therefore does not have an Organizational Conflict of Interest.
5. Port Authority of Guam contracts with an A&E Offeror to develop "low-level" documents prior to establishing a schedule for an RFP in which the "low level" documents, still under development, will be used by prospective Proposers. The A&E Offeror has attended the pre-proposal meeting and wishes to propose on the RFP. Port Authority of Guam determines that the company has a potential Organizational Conflict of Interest because of the fact that the low-level documents have not been made public and the Offeror will still be developing the documents during the solicitation. The company then mitigates the potential conflict of interest by suspending development of new reports during the open period of the solicitation and making all data and information sources available on an Port Authority of Guam website prior to the RFP release. Port Authority of Guam determines that the potential conflict has been adequately managed and the Offeror will not be disqualified from submitting a proposal or being part of the proposing team.

6. Port Authority of Guam contracts with a consulting Offeror to assist Port Authority of Guam in the development of an RFP and sample Contract for a Design-Build Procurement for construction of certain Transportation Projects. The Offeror has close contact with Port Authority of Guam decision-makers in the development of the evaluation criteria for the RFP and the proposed Contract terms, and that information is shared throughout the Offeror with all management and technical personnel. The Offeror will not be able to submit a proposal in the design-build Procurement, or participate as a team member with an Offeror submitting a proposal in response to the RFP.
7. Port Authority of Guam seeks comprehensive program management services for a series of Transportation Projects. Prior to release of the RFP, Port Authority of Guam shared its interpretation of the applicable conflict of interest requirements with the industry. One of the proposing Offerors has a related entity with a planned interest in future design-build construction work related to the transportation program. The COI Disclosure Form does not clearly state whether the related entity is a subsidiary, major partner, Subcontractor, or affiliate of a Subcontractor. The proposing Offeror describes its intent to restrict the flow of information concerning construction Projects to the related entity and thereby to its affiliate construction company but does not clarify how much information will be shared between the principal and its Subcontractors and affiliates or the controls placed on the principal Subcontractor-affiliate relationship. Furthermore, the proposing Offeror has provided mitigation information, indicating that the related entity will not participate in providing services under the program management Contract (i.e., design, source selection, award of Contract, etc.). Port Authority of Guam may conclude the proposing Offeror does not have a conflict of interest that detracts from its eligibility for the program management award. Port Authority of Guam may determine that the related entity has a conflict of interest in future design-build construction work related to the bridge repair and replacement program that has not been adequately mitigated by the measures and information provided by the proposing Offeror. As a result, if the proposing Offeror is awarded the program management Contract, the related construction company will be ineligible for construction work under the program. This determination will depend upon the precise relationship between the related entity and the Proposer.
8. Completion of a project may encourage construction of a shopping center or industrial park from which an Offeror stands to benefit. If an Offeror is aware that it has such an interest in the decision on the proposal, it will be disqualified from preparing an EIS to preserve the objectivity and integrity of the NEPA process.
9. Port Authority of Guam issues an RFP for A&E services to prepare plans, specifications, and estimate (PS&E) to replace a bridge. The PS&E will be completed as part of a design-bid-build process. One of the A&E firms proposing on the design services owns XYZ Inc., a subsidiary that provides program management services to Port Authority of Guam under a separate contract. Port Authority of Guam's intent, as advertised in the RFP, is to use XYZ Inc. for administration and oversight of the A&E design services for the bridge replacement project. The A&E firm that is the parent of XYZ Inc. would be ineligible for award of the A&E design contract.
10. Port Authority of Guam issues an IFB for construction services to replace a bridge. The replacement is being done using the design-bid-build process. One of the construction firms bidding on the public improvement project owns XYZ Inc., a subsidiary that provides construction contract administration and inspection services to Port Authority of Guam under a separate contract. Port Authority of Guam's intent, as advertised in the IFB, is to use XYZ Inc. for administration and inspection of the bridge replacement project. The construction firm that is the parent of XYZ Inc. would be ineligible for award of the construction contract.

DEFINITIONS

The following definitions apply to these COI Guidelines and the Port Authority of Guam's COI Disclosure Form:

"Actual Conflict of Interest" means that an individual or Offeror is unable to render impartial assistance or advice to Port Authority of Guam, has impaired objectivity in performing the Project work, or has an unfair competitive advantage. **"Actual Conflict of Interest"** means any action or any decision or recommendation by a person acting in a capacity as a public official, the effect of which would be to the private pecuniary benefit or detriment of the person or the person's relative or any business with which the person or a relative of the person is associated unless the pecuniary benefit or detriment arises out of the circumstances described in the definition for **"Potential Conflict of Interest"** (see definition below).

"Affiliate" (of an Offeror) means a person or entity that, directly or indirectly through one or more intermediaries, controls, is controlled by, or is under common control of the Offeror.

"Apparent Conflict of Interest" means that an individual or Offeror may reasonably be perceived to have an Actual Conflict of Interest or a Potential Conflict of Interest.

"Associate" (of the Offeror) means an employee, executive, director, key project personnel, consultant, contractor, or Subcontractor, or any immediate family member of the foregoing.

"Authorization" (of the Contract). A public contract is authorized by a Public Employee if the Public Employee participated substantially in the procurement selection process or performed a significant role in the selection of an Offeror or the execution of the Contract. A significant role includes recommending approval or signing of the Contract, including serving as a reference, recommending selection or serving on a selection committee or team, or having the final authorizing authority for the Contract.

"Bidder" means a legally operating business entity submitting a bid in response to a Procurement solicitation.

"Conflict of Interest" or **"COI"** means an Individual Conflict of Interest or Organizational Conflict of Interest and includes an Actual, Potential, or Apparent Conflict of Interest.

"COI Disclosure Form" means a manually signed disclosure of any Actual Conflict of Interest, Apparent Conflict of Interest or Potential Conflict of Interest documented in the form of Port Authority of Guam's COI Disclosure Form.

"COI Guidelines" refers to this document and all references herein.

"Contract" means an Agreement, Contract, Purchase Request (PR), Work Order Contract (WOC), Purchase Order (PO), or any other type agreement with Port Authority of Guam, regardless of what it may be called, for the procurement or disposal of supplies, services, or construction.

"Contractor" means a legally operating business entity that has been awarded a contract in response to a Procurement.

"Correct" means, in the context of determining the accuracy of a COI Disclosure Form, that the form, in all material respects, is complete, accurate, not misleading, and does not omit any material information.

"Immediate Family Member" (of the Public Employee) means a spouse, children, parents, brothers and sisters, grandparents and grandchildren, mothers-in-law and fathers-in-law, brothers-in-law and sisters-in-law, daughters-in-law and sons-in-law. Stepsiblings, stepchildren and stepparents shall also be regarded as immediate family.

"Individual Conflict of Interest" means that an individual has a conflict of interest because of a financial interest, gift, or other activities or relationships with other persons including but not limited to individuals with whom the individual has business, familial or household relationships.

"Interest" (in the context of a conflict of interest) means a direct or indirect interest and includes a personal as well as financial interest.

"Low-Level Document" means A&E, non-A&E and IT program or Project-related documents which provide a basic understanding of a specific aspect of the program or Project. With regard to A&E and related services, it means that the role of the consultant or subconsultant was limited to provision of preliminary design, reports, or similar "low-level" documents that will be incorporated into the solicitation, and did not include assistance in development of instructions to offerors or evaluation criteria.

"Member of the Household" (of the Public Employee) means any person who resides with the Public Employee.

"Offeror" means a Proposer or Bidder under a Procurement solicitation, a consultant or contractor under a Contract, or a Subcontractor at any tier of a Proposer, consultant, or contractor, and any partner or member of any of the foregoing. An Offeror includes all persons, individual or corporate, without regard to form of legal entity, and any partner or member of any of the foregoing.

"Organizational Conflict of Interest" means that a relationship or situation exists whereby an Offeror or any of its Associates has past, present, or currently planned interests or activities that either directly or indirectly (through a client, contractual, financial, organizational or other relationship) may relate to the work to be performed under the proposed Contract with Port Authority of Guam and which: (a) diminish the Offeror's or an Associate's capacity to give impartial, technically sound, objective assistance or advice; (b) may impair the Offeror's or an Associate's objectivity in performing the Contract; (c) may impair Port Authority of Guam's objectivity in oversight of the Contractor's performance; or (d) may result in an unfair competitive advantage. It does not include the normal flow of benefits from the performance of the Contract.

"Potential Conflict of Interest" means that an individual or Offeror, as a result of current plans, may reasonably be expected to have an actual conflict of interest. "Potential Conflict of Interest" means any action or any decision or recommendation by a person acting in a capacity as a public official, the effect of which could be to the private pecuniary benefit or detriment of the person or the person's relative, or a business with which the person or the person's relative is associated, unless the pecuniary benefit or detriment arises out of the following: (a) an interest or membership in a particular business, industry, occupation or other class required by law as a prerequisite to the holding by the person of the office or position; (b) any action in the person's official capacity which would affect, to the same degree, a class consisting of all inhabitants of the state or a smaller class consisting of an industry, occupation or other group including one of which or in which the person, or the person's relative or business with which the person or the person's relative is associated, is a member or is engaged; or (c) membership in or membership on the board of directors of a nonprofit corporation that is tax-exempt under section 501(c) of the Internal Revenue Code.

"Procurement" means a Request for Proposals (RFP), Request for Quotes (RFQ), Request for Information (RFI), Invitation for Bid (IFB), or any other form of solicitation or Procurement by Port Authority of Guam.

"Project" means any proposed or existing undertaking pertaining to such programs that are assigned to Port Authority of Guam under applicable law.

"Proposal" means a bid, proposal, or other submission appropriate to a Procurement.

"Proposer" means a legally operating business entity submitting a Proposal in response to a Procurement.

"Public Disclosure" means the work product or service (in connection with the preparation of a Procurement) is available for public review and analysis for a reasonable amount of time, typically at least thirty (30) calendar days.

"Public Employee" means any person who is serving the government of Guam or any of its political subdivisions or any other governmental body as defined in 5 GCA § 5125 as an elected official, appointed official, employee, agent, or otherwise, irrespective of whether the person is compensated for the services. (For the purposes of these COI Guidelines, all Port Authority of Guam employees are considered Public Employees under this definition.)

"Relative" (of a Public Employee) means:

- any individual who is related to the public official as father, mother, son, daughter, brother, sister, uncle, aunt, first cousin, nephew, niece, husband, wife, father-in-law, mother-in-law, son-in-law, daughter-in-law, brother-in-law, sister-in-law, stepfather, stepmother, stepson, stepdaughter, stepbrother, stepsister, half brother, or half sister; or

- any individual for whom the Public Employee has a legal support obligation or for whom the Public Employee provides benefits arising from the Public Employee's public employment or from whom the Public Employee receives benefits arising from that individual's employment.

"Subcontractor" means a contractor or subcontractor at any tier lower than the awarded Contractor.

The non-Federal entity must maintain written standards of conduct covering conflicts of interest and governing the actions of its employees engaged in the selection, award and administration of contracts. No employee, officer, or agent may participate in the selection, award, or administration of a contract supported by a Federal award if he or she has a real or apparent conflict of interest. Such a conflict of interest would arise when the employee, officer, or agent, any member of his or her immediate family, his or her partner, or an organization which employs or is about to employ any of the parties indicated herein, has a financial or other interest in or a tangible personal benefit from a firm considered for a contract. The officers, employees, and agents of the non-Federal entity may neither solicit nor accept gratuities, favors, or anything of monetary value from contractors or parties to subcontracts. However, non-Federal entities may set standards for situations in which the financial interest is not substantial or the gift is an unsolicited item of nominal value. The standards of conduct must provide for disciplinary actions to be applied for violations of such standards by officers, employees, or agents of the non-Federal entity.

Section XIII. CONFLICT OF INTEREST (COI) DISCLOSURE FORM

Government of Guam *PORT AUTHORITY OF GUAM* IFB No. PAG-CIP-024-001

Offerors under Contract or proposing to enter into a Contract with *PORT AUTHORITY OF GUAM* must comply with the "Conflict of Interest Guidelines" attached to this solicitation. The definitions of terms used in this COI Disclosure Form shall be those provided in the Conflict of Interest Guidelines (note that "Public Employee" includes all *PORT AUTHORITY OF GUAM* employees).

This COI Disclosure Form is submitted in response to:

PORT AUTHORITY OF GUAM RFP# _____ [or] IFB# PAG-013-024 (check only one)

Contract # _____ (if applicable)

Changes to COI Disclosure Form previously submitted for RFP # _____, IFB # _____, or Contract # _____ (if applicable)

This COI Disclosure Form must be signed in ink by an authorized representative of Offeror to certify that it is correct. An Offeror's certification that its disclosure form is correct includes the disclosure by its Associates and Subcontractors.

My signature certifies that as disclosed on or attached to the present form:

- (a) the Offeror's disclosures are complete, accurate, and not misleading.
- (b) the Offeror has provided the COI Guidelines to all Associates and Subcontractors (if any) and this form includes or has attached any required COI disclosures from those sources.

I hereby certify that I am authorized to sign this COI Disclosure Form as an Authorized Representative for the Offeror identified below:

Complete Legal Name of Offeror: Federal Contracts Corp

Address: 12918 N. Nebraska Ave, Tampa, FL 33612

Telephone: 813-631-0000

Fax No: 813-631-0008

Signature: *Pete Person* Date: 06/06/2024

Please answer all questions "Yes", "No" or "N/A" (if uncertain answer "Yes.") If the answer to any of the questions is "Yes," then use the applicable "Comments" fields to:

- (a) furnish all relevant facts that are necessary to make the response complete, accurate, and not misleading; and

(b) identify any actions that must be taken to avoid, neutralize, or mitigate such conflict of interest (e.g. communications barriers, restraint or restriction upon future contracting activities, or other precaution)

Please add additional sheets as necessary to respond to the "Comments" field.

1. a) Is any Associate of the Offeror a former employee of *PORT AUTHORITY OF GUAM* within the last year? No Yes

b) Is any Associate of the Offeror a Relative, immediate Family Member, or Member of the Household of a current *PORT AUTHORITY OF GUAM* employee that had or will have any involvement with this Procurement or Contract Authorization? No Yes

If the answer to either of the above questions is "Yes", complete the attached "Relatives and Former *PORT AUTHORITY OF GUAM* Employees - Roles and Signatures" table (Part A and/or Part B, as applicable).

2. Does the Offeror or any Associate of the Offeror have an Actual, Apparent or Potential Conflict of Interest ("Individual" or "Organizational") with regard to any known member of an *PORT AUTHORITY OF GUAM* Procurement evaluation or selection team? No Yes

Comments:

3. Did the Offeror or any Associate of the Offeror conduct prior work on the Project described in the Procurement, or participate in preparing any part of the Procurement or any documents or reports related to the Procurement or to which the Procurement refers? No Yes

Comments:

4. Does the Offeror or any Associate of the Offeror have any past, present or currently planned personal or financial interests which are an Actual, Apparent or Potential Conflict of Interest ("Individual" or "Organizational"), with respect to the Procurement or award of this Contract or performing the work for *PORT AUTHORITY OF GUAM* or acquisition of any real property for the Project? No

Yes Comments:

5. Has the Offeror or an Associate of the Offeror offered to a Public Employee, or is the Offeror aware of any Public Employee that has solicited or received, directly or indirectly, any pledge or promise of employment or other benefit based on the understanding that the Public Employee's vote, official action or judgment would be influenced thereby? No Yes

Comments:

6. Has (or will) the Offeror or an Associate of the Offeror provided a direct beneficial financial interest to any person within two years after the person ceased to hold a position as a Public Employee who was involved in the Procurement or Authorization for the Contract, or is the Offeror aware of any such person or Public Employee who has or will receive a direct beneficial financial interest within the two-year period? No Yes Comments:

7. Is the Offeror aware of any current or former Public Employee that has an Actual, Apparent, or Potential Conflict of Interest with respect to the Procurement or award of this Contract or performing the work for *PORT AUTHORITY OF GUAM*? No Yes Comments:

8. Does the prospective Contract/WOC include development of an Environmental Assessment (EA) or Environmental Impact Statement (EIS)? No Yes

If yes, in accordance with the disclosure statement requirements of Council on Environmental Quality Regulation, 40 C.F.R 1506.5(c), does the Offeror have any financial or other interest in the outcome of this Project; and/or does the Offeror have any agreement, enforceable promise, or guarantee to provide any future work on this Project? No Yes

Comments:

9. Have Subcontractors or other Associates furnished COI Disclosure Forms, separate from the present form, which included conflicts or potential conflicts of interest? (If yes, attach the disclosures.) No Yes N/A Comments:

10. If the prospective Contract/WOC includes personal services for the purpose of administering, managing, monitoring, inspecting, evaluating compliance with or otherwise overseeing a public contract, is the Offeror or an Associate or an Affiliate of the Offeror a party to the subject public contract? No Yes N/A Comments:

11. Has the Offeror or any Associate of the Offeror entered into personal services contract(s) with *PORT AUTHORITY OF GUAM* for the purpose of advising or assisting in developing specifications, a scope or statement of work, an invitation to bid, a request for proposals, or other solicitation documents and materials related to this procurement? No Yes Comments:

Relatives and Former *PORT AUTHORITY OF GUAM* Employees - Roles and Signatures

For each employee of the Offeror that was employed by *PORT AUTHORITY OF GUAM* within the last year, state the job the employee performed for *PORT AUTHORITY OF GUAM*, the role the employee now serves for the Offeror and the date the employee left *PORT AUTHORITY OF GUAM*. Use Part B for Offeror Associates with Relatives, Immediate Family Members, or Members of the Household working for *PORT AUTHORITY OF GUAM* that have had or will have involvement with this Procurement or Contract.

Part A: Employees that left *PORT AUTHORITY OF GUAM* in the last year.			
Employee Name/Signature	Job Performed for *PORT AUTHORITY OF GUAM*	Current Role with Offeror	Date left *PORT AUTHORITY OF GUAM*
Name: _____ Sign: _____			

<ul style="list-style-type: none"> Involved with this Procurement on behalf of *PORT AUTHORITY OF GUAM*? No <input type="checkbox"/> Yes <input type="checkbox"/> Involved with Proposal development for this Procurement? No <input type="checkbox"/> Yes <input type="checkbox"/> 			
Name: _____ Sign: _____ <ul style="list-style-type: none"> Involved with this Procurement on behalf of *PORT AUTHORITY OF GUAM*? No <input type="checkbox"/> Yes <input type="checkbox"/> Involved with Proposal development for this Procurement? No <input type="checkbox"/> Yes <input type="checkbox"/> 			
Name: _____ Sign: _____ <ul style="list-style-type: none"> Involved with this Procurement on behalf of *PORT AUTHORITY OF GUAM*? No <input type="checkbox"/> Yes <input type="checkbox"/> Involved with Proposal development for this Procurement? No <input type="checkbox"/> Yes <input type="checkbox"/> 			
<p align="center">Part B: Identify Associates of the Offeror that are Relatives, Immediate Family Members, or Members of the Household of *PORT AUTHORITY OF GUAM* employees currently working for *PORT AUTHORITY OF GUAM*, if the *PORT AUTHORITY OF GUAM* employee had or will have any involvement with this Procurement or Contract.</p>			
Offeror Associate's Name	Name and Relationship of Relative, Immediate Family Member, or Member of Household Employed at *PORT AUTHORITY OF GUAM*	Role at *PORT AUTHORITY OF GUAM*	*PORT AUTHORITY OF GUAM* employee's Role with this Procurement

(Make copies of this form as needed to list additional employees.)

Fwd: Notice of Award for IFB-PAG-013-024 Re-bid 180' Telescopic Boom Lift

From : Annie LG. Sablan <algsablan@portofguam.com> Mon, Jun 10, 2024 08:21 AM
Subject : Fwd: Notice of Award for IFB-PAG-013-024 Re-bid 180' Telescopic Boom Lift 📎 6 attachments
To : Steven P. Muna <spmuna01@portofguam.com>, PAG Procurement <pagprocurement@portofguam.com>

Forwarding email.

Regards,

Annie LG. Sablan
Assistant Procurement & Supply Manager
Port Authority of Guam
1026 CABRAS HWY. SUITE 201 PITI, GUAM 96915
PHONE: (671) 477-5931/5 EXT 250
EMAIL: algsablan@portofguam.com

****CONFIDENTIALITY NOTICE:**

This email and any attachments may contain information that is privileged or confidential. If you are not the intended recipient, please note that dissemination, distribution or copying of this email message and attachments is strictly prohibited. If you have received this email message in error, please advise me by reply email and delete the email message and attachments. Thank you.

From: Pete <pete@federalcontractscorp.com>
To: Mark <macabrera@portofguam.com>
Cc: algsablan <algsablan@portofguam.com>; Steven <spmuna01@portofguam.com>; Pia <pacastro@portofguam.com>
Date: Friday, 7 June 2024 9:57 PM ChST
Subject: RE: Notice of Award for IFB-PAG-013-024 Re-bid 180' Telescopic Boom Lift

Good Morning Mark,

I apologize for the delay. I have been attending a trade show all week.

Attached are the signed acknowledgments. Please let me know if you need anything else.

We greatly appreciate your business.

Thank you,

Pete



Pete Pierson, Vice President

PH: 813.631.0000 FX: 813.631.0008

pete@federalcontractscorp.com

GSA & DLA Contract Holder

"Keeping Government Purchasing Simple"

From: Mark A. Cabrera <macabrera@portofguam.com>

Sent: Thursday, June 6, 2024 1:11 AM

To: Pete Pierson <pete@federalcontractscorp.com>

Cc: algsablan <algsablan@portofguam.com>; Steven P. Muna <spmuna01@portofguam.com>; Pia A. Castro <pacastro@portofguam.com>

Subject: Re: Notice of Award for IFB-PAG-013-024 Re-bid 180' Telescopic Boom Lift

Good Afternoon Mr. Pierson,

Congratulations on your award!!!

Attached is the IFB Contract in which requires your signature for the agreement. Also included is the purchase order that requires your acknowledgment on the second page. Last, I'm still pending the COI and Anti-Lobbying disclosure forms from you, but we can receive them from you all at once. Let me know if you have any questions. Thank You.

Respectfully,

Mark A. Cabrera
Procurement Buyer Supervisor



Port Authority of Guam
1026 Cabras Highway
Suite 201 Piti GU 96915
(671)477-5931 ext. 252
macabrera@portofguam.com

From: "Mark A. Cabrera" <macabrera@portofguam.com>
To: "Pete Pierson" <pete@federalcontractscorp.com>
Sent: Wednesday, June 5, 2024 10:39:17 AM
Subject: Re: Notice of Award for IFB-PAG-013-024 Re-bid 180' Telescopic Boom Lift

Good Morning Mr. Pierson,

We are near the finalization of the Contract and Purchase Order. The attachments are required to be filled out as this award is provided through a Federal Grant. Simultaneously, I will be processing your order and contract in the amount of \$517,205.41. A four percent 4% (\$20,688.22) Withholding Assessment Fee will be applied against the amount, this will be stated on the order and be retained at payment to Federal Contracts Corporation.

The confirmed delivery will read: 180 days as you had indicated in your earlier e-mail. A copy of the contract and purchase order will be sent to you once signed.

Respectfully,

Mark A. Cabrera
Procurement Buyer Supervisor



Port Authority of Guam
1026 Cabras Highway
Suite 201 Piti GU 96915
(671)477-5931 ext. 252
macabrera@portofguam.com

From: "Pete Pierson" <pete@federalcontractscorp.com>
To: "Mark A. Cabrera" <macabrera@portofguam.com>
Sent: Wednesday, May 29, 2024 5:53:39 AM
Subject: RE: Notice of Award for IFB-PAG-013-024 Re-bid 180' Telescopic Boom Lift

Hello Mark,

Attached is our W-9 and business license. Our EIN # is 42-1613127.

Please let me know if you need anything else.

Thank you,

Pete



Pete Pierson, Vice President

PH: 813.631.0000 FX: 813.631.0008

pete@federalcontractscorp.com

GSA & DLA Contract Holder

"Keeping Government Purchasing Simple"

Service Disabled Veteran Owned Small Business, *HUBZone Vendor*

From: Mark A. Cabrera <macabrera@portofguam.com>

Sent: Monday, May 27, 2024 9:25 PM

To: Pete Pierson <pete@federalcontractscorp.com>

Subject: Re: Notice of Award for IFB-PAG-013-024 Re-bid 180' Telescopic Boom Lift

Hello Mr. Peirson-

Can you provide me with a current copy of your business license and W-9 with EIN#?
We need to register Pacific Federal Contracts Corporation as a Port vendor before I can process a purchase order or contract.

Thank You,

Mark A. Cabrera
Procurement Buyer Supervisor



Port Authority of Guam
1026 Cabras Highway
Suite 201 Piti GU 96915
(671)477-5931 ext. 252
macabrera@portofguam.com

From: "Mark A. Cabrera" <macabrera@portofguam.com>
To: "Pete Pierson" <pete@federalcontractscorp.com>
Sent: Tuesday, May 28, 2024 10:22:02 AM
Subject: Re: Notice of Award for IFB-PAG-013-024 Re-bid 180' Telescopic Boom Lift

Mr. Pierson,

Thank you for your quick response. We are preparing the purchase order. I will indicate 180 days delivery on it and will also include the contract cover which is the page from the solicitation that you had acknowledged. Needless to say, the Port is excited regarding this Procurement.

Respectfully,

Mark A. Cabrera
Procurement Buyer Supervisor



Port Authority of Guam
1026 Cabras Highway
Suite 201 Piti GU 96915
(671)477-5931 ext. 252

macabrera@portofguam.com

From: "Pete Pierson" <pete@federalcontractscorp.com>

To: "Mark A. Cabrera" <macabrera@portofguam.com>

Sent: Thursday, May 23, 2024 3:51:43 AM

Subject: RE: Notice of Award for IFB-PAG-013-024 Re-bid 180' Telescopic Boom Lift

Mark,

The lead time right now is 5 month ARO, plus transit time. I would say 30 days transit time to be safe. 180 days total to deliver.

Thank you,

Pete



Pete Pierson, Vice President

PH: 813.631.0000 FX: 813.631.0008

pete@federalcontractscorp.com

GSA & DLA Contract Holder

"Keeping Government Purchasing Simple"

Service Disabled Veteran Owned Small Business, *HUBZone Vendor*

From: Mark A. Cabrera <macabrera@portofguam.com>

Sent: Tuesday, May 21, 2024 10:09 PM

To: Pete Pierson <pete@federalcontractscorp.com>

Subject: Re: Notice of Award for IFB-PAG-013-024 Re-bid 180' Telescopic Boom Lift

Mr. Pierson-

Just wanted to confirm with you if Federal Contracts Corp can deliver within 150 days as noted in your bid submittal? The documents to award are being prepared and should be issued to you very soon.

Respectfully,

Mark A. Cabrera
Procurement Buyer Supervisor



Port Authority of Guam
1026 Cabras Highway
Suite 201 Piti GU 96915
(671)477-5931 ext. 252
macabrera@portofguam.com

From: "Pete Pierson" <pete@federalcontractscorp.com>

To: "Mark A. Cabrera" <macabrera@portofguam.com>

Cc: "Annie Sablan" <algsablan@portofguam.com>

Sent: Tuesday, May 21, 2024 10:09:17 PM

Subject: RE: Notice of Award for IFB-PAG-013-024 Re-bid 180' Telescopic Boom Lift

Hello,

We greatly appreciate your consideration and acknowledge your request.

Thank you,

Pete



Pete Pierson, Vice President

PH: 813.631.0000 FX: 813.631.0008

pete@federalcontractscorp.com

GSA & DLA Contract Holder

"Keeping Government Purchasing Simple"

Service Disabled Veteran Owned Small Business, HUBZone Vendor

From: Mark A. Cabrera <macabrera@portofguam.com>

Sent: Tuesday, May 21, 2024 2:01 AM

To: Pete Pierson <pete@federalcontractscorp.com>

Cc: algsablan <algsablan@portofguam.com>

Subject: Notice of Award for IFB-PAG-013-024 Re-bid 180' Telescopic Boom Lift

Hafa Adai Mr. Pierson-





Congratulations! Kindly acknowledge the attached request so that we may move forward with the Procurement process.

Thank You,

Mark A. Cabrera
Procurement Buyer Supervisor



Port Authority of Guam
1026 Cabras Highway
Suite 201 Piti GU 96915
(671)477-5931 ext. 252
macabrera@portofguam.com

-
-  **Contract IFB-PAG-013-24.pdf**
2 MB
 -  **Purchase Order 19901-OS.pdf**
1 MB
 -  **Attachment B; Conflict of Interest Instructions and Form.pdf**
1 MB
 -  **Attachment A - Telescopic Boom.pdf**
180 KB
-